

# OMNERA<sup>®</sup> 400T

Manual-Positioning Digital Radiographic System

## Operator's Manual



Technical Publication: 2000-095-026-EN Rev. 1.1

**Canon**  
CANON MEDICAL SYSTEMS USA, INC.

### Disclaimer

The standard warranty is void if the product has been intentionally modified, or damaged by accident, abuse or misuse. Additionally, this warranty is void if untrained personnel service the OMNERA®400T equipment.

Lost profits, downtime, goodwill, damage to or replacement of property, and any costs of repairing the OMNERA®400T resulting from a breach of warranty are not the responsibility of Canon Medical Systems.

Specifications are subject to change without notice. Not responsible for typographical errors.

### Notices

No part of this publication may be reproduced, transmitted, transcribed, stored in a retrieval system or translated into any language or computer language, in any form or by any means, electronic, mechanical, magnetic, optical, chemical, manual or otherwise, without the prior written permission of Canon Medical Systems.

**Note:** Photos and drawings used in this guide may be slightly different from the actual product.



Dispose of electronic equipment in accordance with local, state, and federal regulations.

THIS DOCUMENT CONTAINS PROPRIETARY INFORMATION AND SUCH INFORMATION MAY NOT BE DISCLOSED TO OTHERS FOR ANY PURPOSE NOR USED FOR MANUFACTURING PURPOSES WITHOUT WRITTEN PERMISSION FROM CANON MEDICAL SYSTEMS.

### Trademarks

OMNERA® is a registered trademark of Canon Medical Systems.

All third-party brand names, product names, or logos appearing in this manual are the trademarks or registered trademarks of their respective owners.

Canon® is a registered trademark of Canon, Inc. and may also be a registered trademark or a trademark in other countries.



<b>Reason for change</b>	<b>Rev</b>	<b>Date</b>
First release	1.1	2024-09



# Contents

<b>1</b>	<b>Introduction .....</b>	<b>1</b>
1.1	Document Information .....	1
1.1.1	<i>System Documentation</i> .....	1
1.1.2	<i>Stylistic Conventions</i> .....	1
1.1.3	<i>Document Producer</i> .....	1
1.1.4	<i>Copyright © 2024 Arcoma Corporation All Rights Reserved.</i> .....	1
1.1.5	<i>Text Emphasis</i> .....	2
1.2	Identification Labels .....	3
1.3	System Description .....	6
1.3.1	<i>Intended Use</i> .....	6
1.3.2	<i>Intended Users</i> .....	6
1.3.3	<i>Patient Target Group</i> .....	6
1.3.4	<i>Expected Clinical Benefits</i> .....	6
1.3.5	<i>System Overview</i> .....	6
<b>2</b>	<b>Safety .....</b>	<b>13</b>
2.1	Compliance .....	13
2.2	Precautions, Safety .....	14
2.3	Report of Incident .....	17
2.4	Qualifications of Personnel .....	18
2.4.1	<i>Operating Personnel</i> .....	18
2.4.2	<i>Service Personnel</i> .....	18
2.5	Service and Maintenance .....	19
2.6	Installation and Repair .....	20
2.7	Safety and Warning Symbols .....	21
2.8	Safety and Warning Labels on the Equipment .....	22
2.9	Applied parts .....	23
2.10	Essential Performance and Basic Safety .....	24
2.11	Emergency Stop .....	25
2.12	Radiation and X-ray Tube .....	26
2.12.1	<i>Radiation Protection</i> .....	27
2.13	Mechanical Safety .....	32
2.13.1	<i>General</i> .....	32
2.13.2	<i>Overhead Tube Crane</i> .....	33
2.13.3	<i>Cabinet</i> .....	35
2.13.4	<i>Table</i> .....	36
2.13.5	<i>Wallstand</i> .....	43
2.14	Safety Functions .....	45
2.14.1	<i>Opposite Buttons Pressed</i> .....	45
2.14.2	<i>Dead Man's Grip</i> .....	45
2.14.3	<i>Watchdog</i> .....	45
2.14.4	<i>Two Column Table (option)</i> .....	45
2.14.5	<i>Closed Table</i> .....	46
2.14.6	<i>Wallstand</i> .....	47
2.15	IT- and Cyber Security .....	48
2.16	Safety Zone, Definition .....	49
2.16.1	<i>Table</i> .....	49
2.16.2	<i>Wallstand</i> .....	49
2.17	Electromagnetic Compatibility (EMC) .....	50
<b>3</b>	<b>User Interfaces .....</b>	<b>57</b>
3.1	Description .....	57
3.2	Overhead Tube Crane .....	58
3.2.1	<i>Patient Information</i> .....	60
3.2.2	<i>Position Information</i> .....	60

# Contents

---

3.2.3	Workstation Mode .....	61
3.2.4	Adjustment of Generator Parameters (kV, mA, ms, mAs).....	64
3.2.5	Selection Of Technique Mode.....	65
3.2.6	Patient Size .....	67
3.2.7	Collimator Centering.....	67
3.2.8	Hospital Method Book .....	68
3.2.9	Automatic Collimator (option) .....	68
3.2.10	Setting Menu .....	72
3.2.11	Light Indication.....	79
3.3	Wallstand Control Elements.....	80
3.3.1	Tiltable Imaging Unit Holder (option).....	80
3.3.2	Wallstand Controls .....	81
3.4	OTC Control Elements .....	83
3.4.1	Direction of Movement.....	83
3.5	Manual Collimator.....	84
3.6	Automatic Collimator (option).....	85
3.6.1	General .....	85
3.6.2	Basic Flow of Operation.....	85
3.6.3	Display and Control Elements .....	86
3.7	DAP (option).....	91
3.8	Table Control Elements .....	92
3.8.1	Directions of Movement .....	92
3.8.2	Directions of Movement .....	92
3.8.3	Indication of Power to the Table.....	93
3.8.4	Foot Control, Table X/Y/Z (option) .....	94
3.8.5	XY Foot Control, Strip Type (option).....	94
3.8.6	Table Hand Control .....	96
3.8.7	Moving Table Top.....	96
3.9	Image System CXDI NE Software .....	97
3.9.1	General .....	97
3.9.2	Features.....	97
3.9.3	Name Descriptions.....	98
3.9.4	Generator Parameter Display Window .....	98
3.9.5	Control Panel.....	99
3.9.6	Radiography Controls.....	100
3.9.7	Exam Tab.....	106
3.9.8	Past Tab.....	126
3.9.9	Online - Offline.....	128
3.9.10	System View.....	129
3.9.11	Detector Status.....	154
<b>4</b>	<b>Operating the System.....</b>	<b>155</b>
4.1	General.....	155
4.2	Turn on the System .....	157
4.3	Turn off the System .....	159
4.4	Perform Examination .....	161
4.4.1	Select Patient .....	161
4.4.2	Start Examination.....	161
4.4.3	Workstation Indication Light .....	162
4.4.4	Position OTC and Wallstand .....	163
4.4.5	Position OTC and Table.....	164
4.4.6	Adjust Position and Collimator For Chosen Examination and Patient.....	165
4.4.7	Exposure.....	166
4.4.8	Review Image.....	168
4.4.9	Change Workspace.....	168

# Contents

4.4.10	Basic Exposure Error Handling.....	169
4.5	Emergency Patient .....	170
4.6	Perform a Stitching Sequence.....	171
4.7	System Techniques.....	175
4.7.1	Free Technique.....	175
4.7.2	Table Tracking .....	176
4.7.3	Auto Tracking, Wallstand .....	178
4.8	Operating the Table.....	181
4.8.1	General.....	181
4.8.2	Functional Description, Closed Table 0181.....	181
4.8.3	Detector, Table.....	184
4.8.4	Grid, Table.....	188
4.8.5	Attach/Remove Accessories .....	190
4.9	Operating the Wallstand .....	191
4.9.1	General.....	191
4.9.2	Functional Description.....	192
4.9.3	Detector, Wallstand .....	196
4.10	Super User.....	204
4.10.1	Change Exposure Parameters .....	204
4.10.2	Service Program, Log in .....	210
4.10.3	Collect Log Files .....	212
4.10.4	Export Images .....	214
4.10.5	Adjustment of Protocol.....	216
4.10.6	Pre-pack – RIS-connection .....	219
4.10.7	Stitching Protocol Definition .....	220
<b>5</b>	<b>Error Handling.....</b>	<b>229</b>
5.1	Fault Handling .....	229
5.1.1	Notifications.....	229
<b>6</b>	<b>Cleaning and Disinfection .....</b>	<b>233</b>
6.1	General.....	233
6.1.1	Cleaning and Disinfection Permitted with System Switched ON.....	233
6.2	Cleaning .....	234
6.3	Disinfection .....	235
6.4	Maneuver Handle and Display .....	236
<b>7</b>	<b>Function and Safety Checks .....</b>	<b>237</b>
7.1	AEC Functional Check .....	237
7.2	Safety Checks .....	238
7.2.1	General.....	238
7.2.2	Maintenance.....	238
7.3	Daily .....	239
7.4	Monthly Checks.....	240
7.4.1	Checklist .....	240
7.5	Annual Checks .....	241
<b>8</b>	<b>Complying Standards .....</b>	<b>243</b>
<b>9</b>	<b>Technical Specification .....</b>	<b>245</b>
9.1	Classification.....	245
9.2	Power Requirements .....	246
9.3	Power Line Requirements .....	247



# Contents

---

9.4	Radiographic Specification .....	248
9.5	Environmental Requirements.....	250
9.6	OTC .....	251
9.6.1	<i>General</i> .....	251
9.6.2	<i>Weight</i> .....	251
9.6.3	<i>Speed</i> .....	251
9.7	Cabinet.....	252
9.7.1	<i>General</i> .....	252
9.8	Closed Table .....	253
9.8.1	<i>Maximum Patient Load</i> .....	253
9.8.2	<i>Weight of Parts</i> .....	253
9.8.3	<i>Vertical Lift</i> .....	253
9.8.4	<i>Table Top</i> .....	253
9.9	Two Column Table (option) .....	254
9.9.1	<i>General</i> .....	254
9.10	Wallstand .....	255
9.10.1	<i>Attenuation Equivalent</i> .....	255
9.10.2	<i>Weight</i> .....	255
<b>10</b>	<b>Waste Disposal .....</b>	<b>257</b>
<b>11</b>	<b>Accessories and Options.....</b>	<b>259</b>
11.1	General.....	259
11.2	Options .....	260
11.2.1	<i>General</i> .....	260
11.2.2	<i>Table</i> .....	260
11.2.3	<i>Wallstand</i> .....	261
11.2.4	<i>Detectors</i> .....	261
11.2.5	<i>System Cabinet</i> .....	262
11.2.6	<i>Wallstand loading</i> .....	262
<b>12</b>	<b>Appendix A.....</b>	<b>263</b>
12.1	Glossary .....	263
<b>13</b>	<b>Appendix B.....</b>	<b>267</b>
13.1	Monthly Checklist.....	267
13.1.1	<i>System</i> .....	267
13.1.2	<i>OTC</i> .....	267
13.1.3	<i>Closed Table</i> .....	267
13.1.4	<i>Two Column Table</i> .....	268
13.1.5	<i>Wallstand</i> .....	268
13.1.6	<i>Remark</i> .....	269
13.2	Annual Checks .....	270

# 1 Introduction

## 1.1 Document Information

- It is important to keep this document for the life of the equipment, and pass the document on to any subsequent holder or user of the equipment.
- The original version of this manual is written in English.
- Training is provided by or via Canon Medical Systems. Training material consists of the Operator's Manual and the Installation and service manual.

### 1.1.1 System Documentation

The following documentation is available for the system:

- Omnera System installation and service manual
- Omnera System operation manual
- Omnera System planning guide
- Image system service manual
- Image system user manual
- Detector user's manual

### 1.1.2 Stylistic Conventions

All warning label texts are shown in *italic* style in this manual.

All references are shown in *italic* style in this manual.

### 1.1.3 Document Producer

This document has been produced by:



Arcoma AB  
Annvägen 1  
S-352 46 VÄXJÖ, Sweden

[www.arcoma.se](http://www.arcoma.se)

Detectors and x-ray chain are not included in the CE marking of this device, but hold their own CE marking. These components are combined under Article 22 of MDR 2017/745 EU in a manner that is compatible with the intended purpose of these devices and are subject to internal monitoring, verification and validation by Arcoma AB.

### 1.1.4 Copyright © 2024 Arcoma Corporation All Rights Reserved

The reproduction, transmission or use of this document or its content is not permitted without express written authority. Offered will be liable for damages. All rights, including rights created by patent grant or registration of a utility model or design, are reserved.

# Introduction

## Document Information

---

### 1.1.5 Text Emphasis



#### **WARNING!**

---

*All texts labelled with “WARNING” call attention to potential risk to health or life.*

---

#### **CAUTION!**

---

*All texts labelled with “CAUTION” contain information about dangerous situations and measures to avoid risk.*

---

#### **Note!**

---

*All texts labelled with “NOTE” contain additional information regarding the work step, and is provided for a better understanding or as a warning about unnecessary and avoidable difficulties.*

---

### 1.2 Identification Labels

The figure shows the location of the identification labels on the equipment.

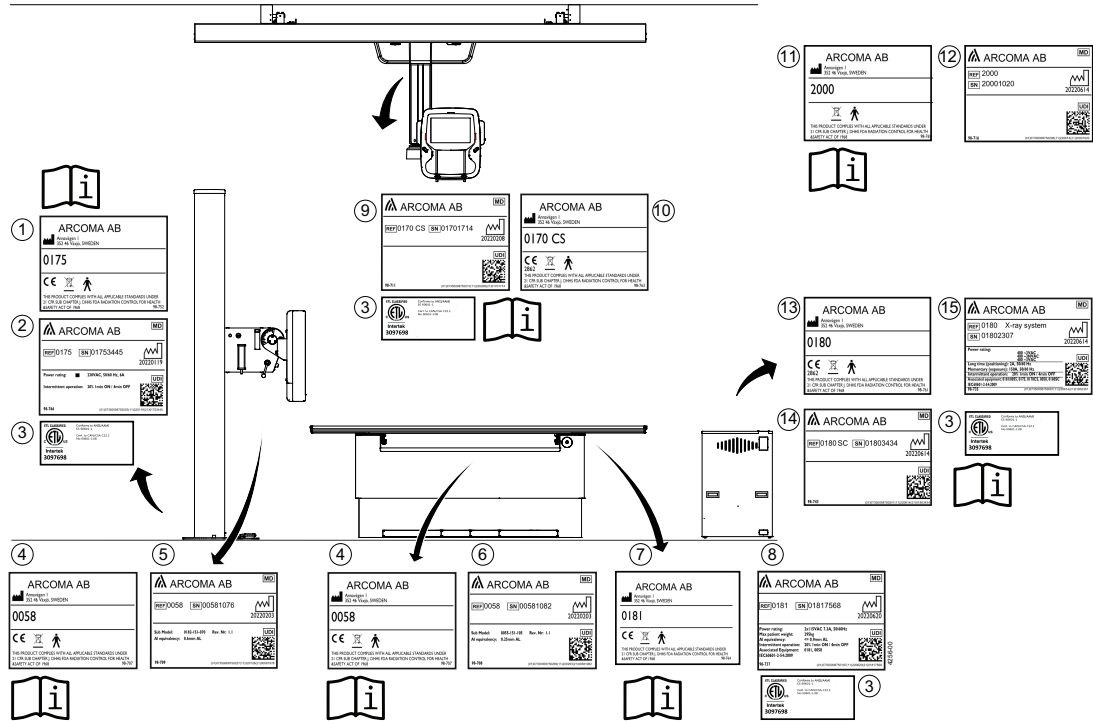

Fig. 1-1

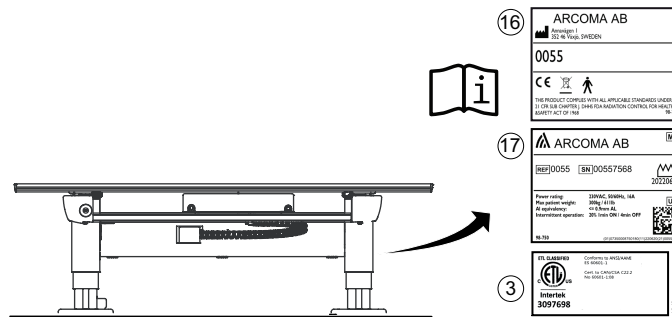

Fig. 1-2

# Introduction

## Identification Labels



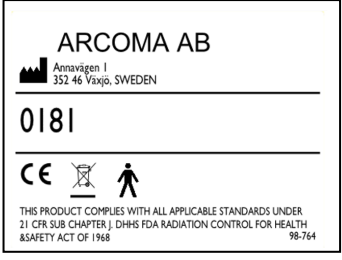
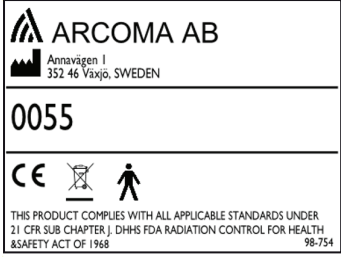



Table 1-1 . Identification Labels

No	Label	No	Label
1		10	
2		11	
3		12	
4		13	
5		14	



# Introduction

## Identification Labels

No	Label	No	Label
6		15	
7		16	
8		17	
9			

### 1.3 System Description

#### 1.3.1 Intended Use

Stationary X-ray device intended for obtaining radiographic images of various portions of the human body in a clinical environment.

The system is not intended for mammography.

#### 1.3.2 Intended Users

The intended user of the X-ray system is a radiographer (technologists).

Radiographers mostly schedule, prepare, perform, and finalize X-ray examinations. The Radiographer must be able to physically operate the system. This includes sufficient capabilities in hearing, vision, and mobility.

In some cases, or countries, the X-ray system is operated by especially trained nurses or doctors.

Minimum skills are knowledge in:

- Westernized Arabic numerals
- General radiographic positioning and procedures
- Anatomy
- Radiation protection
- Hygiene and basic infection control

The detailed qualifications required to operate an X-ray system are defined by local legal regulations.

#### 1.3.3 Patient Target Group

- Age: Newborn to geriatric
- Patient Weight: 0-300 kg
- Health: Patients vary from healthy to affected by multiple traumas.

Special attention shall be given to the patient dose when the device is used for new-born patients.

#### 1.3.4 Expected Clinical Benefits

The major clinical benefit for the patient is the possibility to undergo safe radiologic examination, the results of which may contribute to diagnosis of injury or disease, or follow-up of therapy. The x-ray examination as such is rarely the sole factor to determine patient management, but several parameters contribute. Thus, clinical outcome cannot be directly correlated with Omnera 400T, but has to be related to the overall benefit of diagnosis.

#### 1.3.5 System Overview

The system may be configured in several different versions with a base consisting of an image system, a cabinet and an overhead tube crane. Starting with the base system, there are possible options to include a wallstand and/or a table.

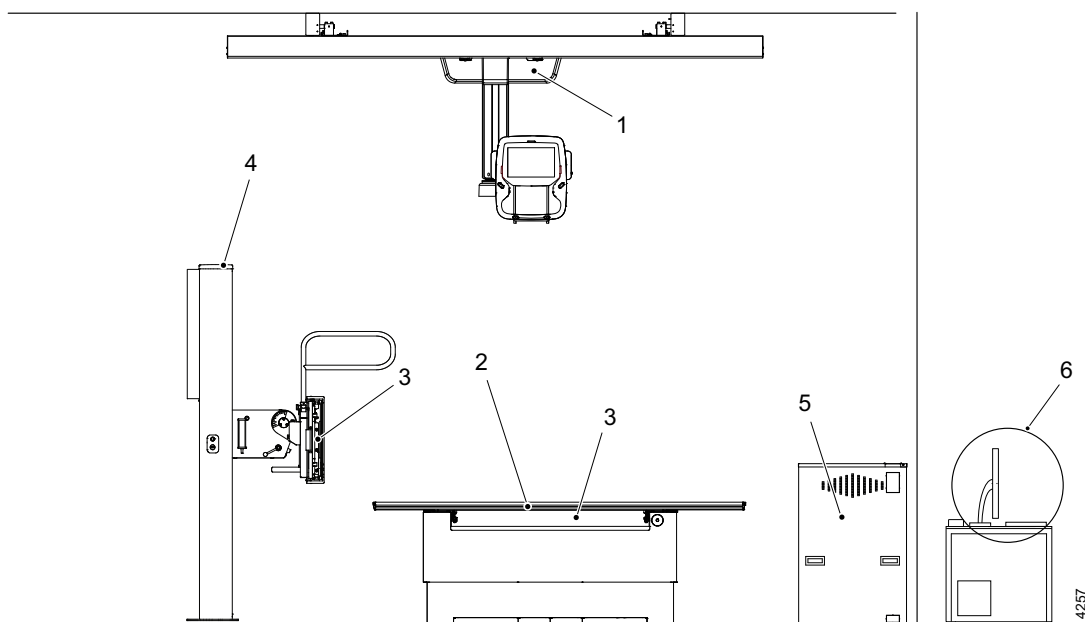

*Fig. 1-3 Main parts*

1. Overhead tube crane, OTC
2. Closed table or two column table (option)
3. Detector holder
4. Wallstand
5. Cabinet
6. Image system PC

# Introduction

## System Description

### 1.3.5.1 Overhead Tube Crane Overview

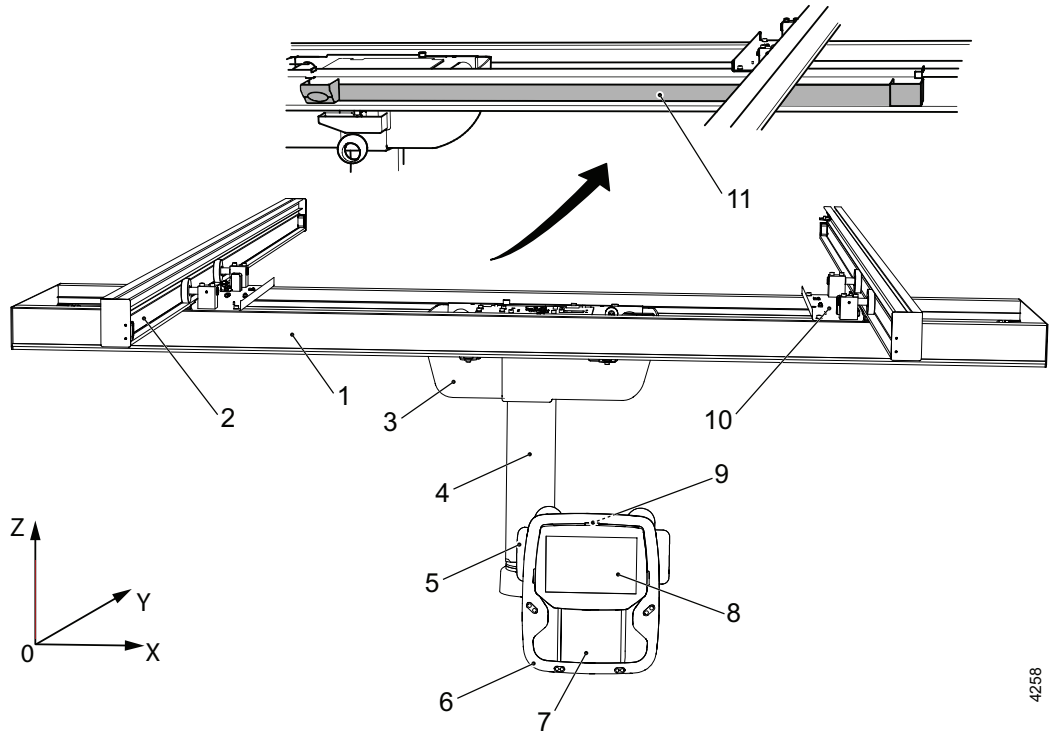

Fig. 1-4 Overview

- |                      |                              |
|----------------------|------------------------------|
| 1. Traverse rail (X) | 7. Collimator                |
| 2. Ceiling rail (Y)  | 8. Display                   |
| 3. Ceiling wagon     | 9. Emergency stop            |
| 4. Column (Z)        | 10. Distance plate and brake |
| 5. X-ray tube        | 11. Cable channel            |
| 6. Manoeuvre handle  |                              |

4258

### 1.3.5.2 Table

#### Closed table

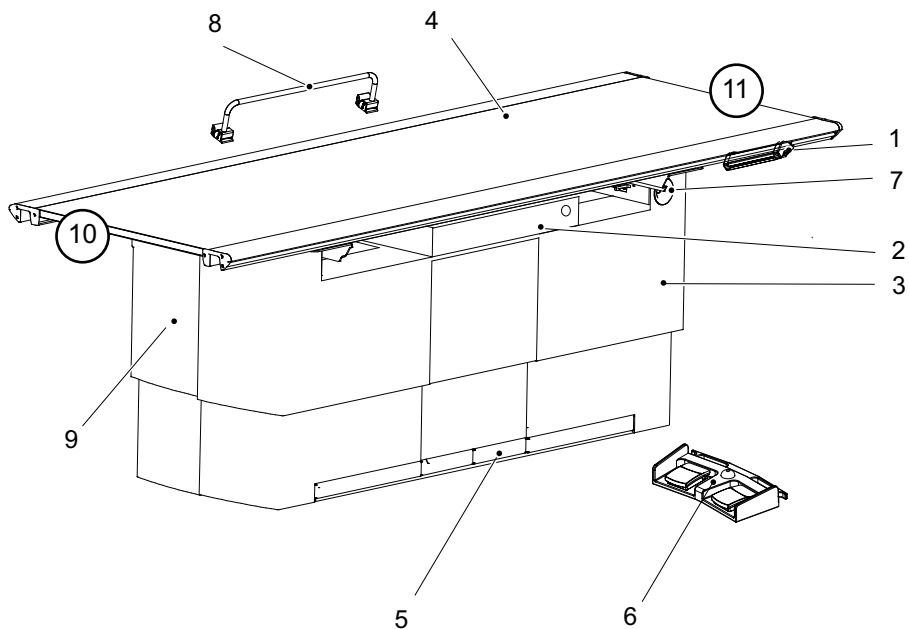

Fig. 1-5 Closed table

- |                                    |   |
|------------------------------------|---|
| 1. Manoeuvre hand control (option) | 7. Emergency stop                           |
| 2. Detector holder                 | 8. Patient hand grip (option)               |
| 3. Vertical lift                   | 9. Brake release button for detector holder |
| 4. Table top                       | 10. Head end                                |
| 5. Kick box control                | 11. Foot end                                |
| 6. Foot control (option)           |   |

#### Models and designs

The table is prepared for different types of detectors, fixed or portable in different sizes.



# Introduction

## System Description

---

### Two Column Table (option)

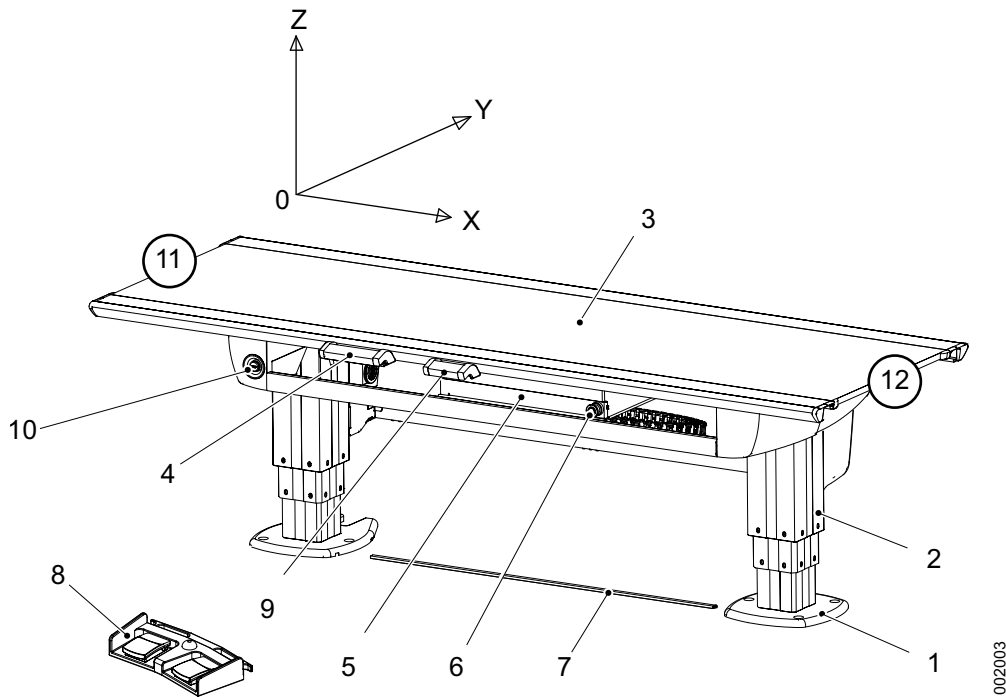

Fig. 1-6 Two column table with manual detector movement

- |   |  |
|---|--|
| 1. Foot plate                               | 7. XY foot control strip type (option) |
| 2. Column                                   | 8. Foot control table (X/Y/Z) (option) |
| 3. Table top (X/Y/Z)                        | 9. Collimator hand control (option)    |
| 4. Table hand control (X/Y/Z)               | 10. Emergency stop                     |
| 5. Detector holder                          | 11. Head end                           |
| 6. Brake release button for detector holder | 12. Foot end                           |

### Models and Designs

The table is prepared for different types of detectors, fixed or portable in different sizes.

### 1.3.5.3 Wallstand Overview

The figure shows the main parts of the wallstand.

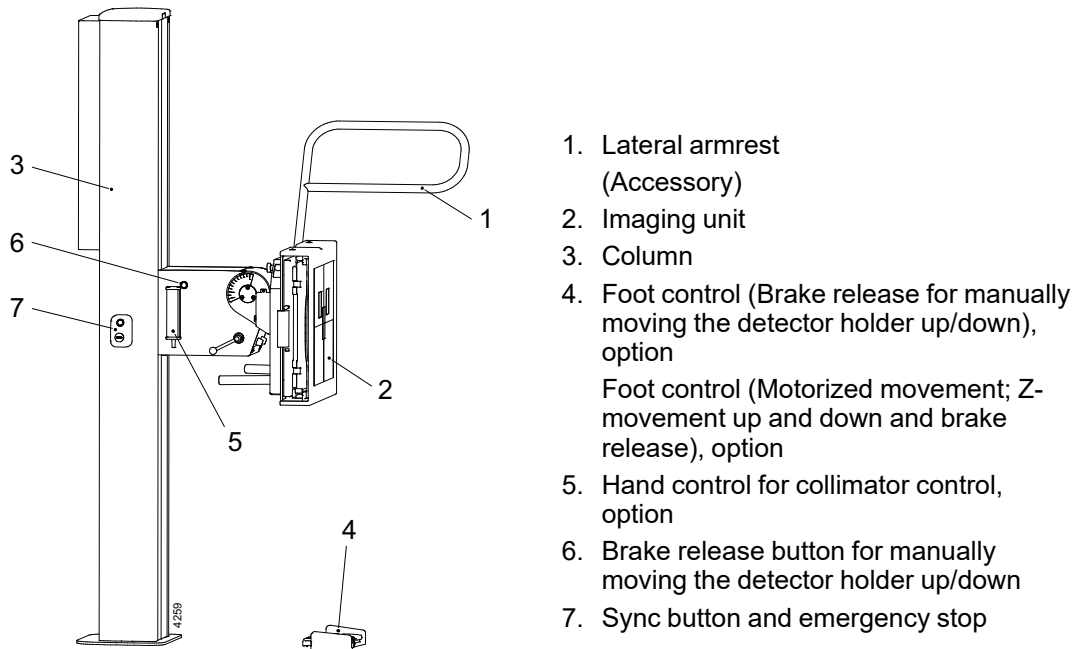

Fig. 1-7 Wallstand Overview

### Models and Designs

The wallstand has different options:

- Tiltable detector holder wagon.
- Motorized Z movement.
- Prepared for different types of detectors; fixed or portable in different sizes.
- The detector/receptor holder for the portable detector is available for either left-hand or right-hand loading.

### Intended Use, Wallstand

The wallstand is intended for use in a hospital environment during radiographic diagnostic examinations together with an X-ray tube support and a detector. The main purpose of the wallstand is to hold and position the detector.

# Introduction

## System Description

---

## **2 Safety**

### **2.1 Compliance**

External equipment intended for connection to signal input, signal output or other connectors shall comply with the relevant product standard e.g. IEC 60950–1 for IT equipment and the IEC 60601–series for medical electrical equipment.

In addition, all such combinations – systems – shall comply with the safety requirements stated in the general standard IEC 60601–1, edition 3.1, clause 16. Any equipment not complying with the leakage current requirements in IEC 60601–1 shall be kept outside the patient environment, i.e. at least 1.5 m from the patient support.

Any person who connects external equipment to signal input, signal output or other connectors has formed a system and is therefore responsible for the system to comply with the requirements.

If in doubt, contact qualified medical technician or your local representative.

If external equipment is connected, an isolation device is needed to isolate the equipment located outside the patient environment from the equipment located inside the patient environment. In particular such a separation device is required when a network connection is made. The requirements on the separation device is defined in IEC 60601–1, edition 3.1, clause 16.

This product conforms to DHHS radiation Standards of 21 CFR subpart J as of the date of manufacture.

# Safety

## Precautions, Safety

---

### 2.2 Precautions, Safety



**WARNING!**

*No modification of this equipment is allowed.*

---



**WARNING!**

*The equipment is intended for use in radiographic examinations under the guidance of trained health care professionals. Operating personnel must be familiar with the equipment, and the instructions given in this manual before using the equipment.*

---



**WARNING!**

*Safety devices must not be removed or modified. Any modification or removal will immediately impair the safety.*

---



**WARNING!**

*All motorized movements shall be supervised by trained personnel.*

---



**WARNING!**

*Do not use non-medical electrical devices in the X-ray room.*

---



**WARNING!**

*Do not use this device if you see smoke or notice unusual odors or noises.*

*If smoke, unusual odors or noise are being generated, continued use of this product may result in fire.*

*Turn OFF the power source breaker immediately, unplug the device, and contact your nearest service representative. Do not attempt to repair it.*

---





**WARNING!**

---

*Risk of electrical hazard or damage to the system*

- *Before cleaning or disinfection, switch off the system to prevent electric shocks, for exceptions see 6.1.1*
  - *Do not spray or pour cleaning liquid on any part of the system.  
Use a lint-free cloth moistened with a moderate amount of liquid to avoid that cleaning liquids seep into the openings of the system, e.g., air openings, gaps between covers.*
  - *Do not restart the system if cleaning liquids have leaked in.*
- 

**CAUTION!**

---

*Do not use any flammable or explosive gases near the device.*

---

**CAUTION!**

---

*Before using this device, read the manuals supplied with the devices in order to understand functions, operation, and performance. Follow the manuals for correct procedures.*

---

**CAUTION!**

---

*Before using the device again after a longer period of time, check the correct operation of the system.*

---

**CAUTION!**

---

*The system is provided with air intakes and outlets to prevent the equipment from overheating. Do not block these air intakes and outlets.*

---

**CAUTION!**

---

*Handle loose objects with care, so they will not fall down on patient or at the surrounding articles.*

---

**CAUTION!**

---

*When using this device, be sure to observe the installation environment requirements regarding temperature, humidity, and power rating conditions, or restriction of use near a device generating strong magnetic or electromagnetic waves.*

---

# Safety

## Precautions, Safety

---

### **CAUTION!**

---

*The installation environment and location, device configuration, network, power supply, and other conditions are optimized for this device. If you want to change any condition, contact your nearest service representative. Otherwise, the functions and performance of this device may be impaired.*

---

### **CAUTION!**

---

*No objects shall be positioned within the working area. If necessary, they must be removable.*

---

### **CAUTION!**

---

*Do not put liquids, or foreign objects such as pins and clips into the equipment.*

*Otherwise, fires, electric shocks, or malfunctions may result.*

*Turn OFF the power source breaker immediately and unplug the equipment if any foreign objects have fallen into the equipment. Contact your nearest service representative.*

*Never disassemble the device.*

---

### **CAUTION!**

---

*The display must not be used for diagnostic purposes.*

---

### **CAUTION!**

---

*Federal law restricts this device to be sold by or on the order of a physician. (US market only.)*

---

### **CAUTION!**

---

*If cracks appear on the display, immediately stop using it. Never use it when the display is damaged.*

---

### **Note!**

---

*Radio interference standard Federal Communications Commission (FCC) Part 15 Class B applies to this equipment.*

---

### **Note!**

---

*The equipment may only be used as intended.*

---

## **2.3 Report of Incident**

*Note!*

---

*Any serious incident that has occurred in relation to the device should be reported to the manufacturer and the competent authority of the Member State in which the user and/or patient is established*

---

# Safety

## Qualifications of Personnel

---

### 2.4 Qualifications of Personnel



#### **WARNING!**

---

*The equipment is intended for use in radiographic examinations under the guidance of trained health care professionals. Operating personnel must be familiar with the equipment, and the instructions given in this manual before using the equipment.*

---

#### 2.4.1 Operating Personnel



#### **WARNING!**

---

*Failure to follow the instructions given in this Manual could result in serious injury to the service person, patient and operator.*

---

Before using the system it is required that the operating personnel is thoroughly familiar with the system and its operating instructions, in particular:

- Safety
- Function and Safety Checks

#### **Note!**

---

*It is the responsibility of the owner to ensure that the system is operated only by trained radiologist, service technicians or product specialists.*

---

#### 2.4.2 Service Personnel



#### **WARNING!**

---

*Before performing any service or maintenance, always switch off the power and lock the main switch to prevent accidental reactivation.*

*Even after the system is powered off, and the main switch is disengaged, live parts remain energized for some time.*

*Wait at least 5 minutes before removing the generator cover, and at least 15 seconds before working on the rest of the system.*

---

The equipment shall be serviced only by service technicians who:

- are completely familiar with the System
- have read and understood *Operator's Manual* and *Installation and Service Manual*.
- know how to remove power to the unit in case of an emergency
- are trained in the use of equipment and procedures of this type.

#### **Note!**

---

*It is the responsibility of the owner to ensure that the technicians have the correct training and knowledge to perform service and maintenance.*

---

## 2.5 Service and Maintenance



**WARNING!**

---

*Risk of electrical shock.*

*If covers are removed, live parts are exposed.*

---



**WARNING!**

---

*Before performing any service or maintenance, always switch off the power and lock the main switch to prevent accidental reactivation.*

*Even after the system is powered off, and the main switch is disengaged, live parts remain energized for some time.*

*Wait at least 5 minutes before removing the generator cover, and at least 15 seconds before working on the rest of the system.*

---



**WARNING!**

---

*Service and maintenance shall only be performed when no patient is present.*

- *Risk for personal injury.*
- 

The equipment must be checked according to the **7 Function and Safety Checks** to maintain reliability and serviceability, and to ensure the safety of the patients, the operator, and third parties.

If national rules or regulations specify more frequent checks and/or maintenance, such regulations must be observed.

# Safety

## Installation and Repair

---

### 2.6 Installation and Repair



#### **WARNING!**

---

**To avoid risk of electric shock, this equipment must only be connected to a supply mains with protective earth.**

---

#### **CAUTION!**

---

**Only service technicians are allowed to open the covers.**

---

#### **CAUTION!**

---

**Do not remove, disassemble, change, modify, repair, or add any part.**

---

#### **CAUTION!**

---

**When installing this equipment in a different location, contact the manufacturer or the designated dealer.**

---

#### **Note!**

---

*For exchange of the collimator light field lamp, see the Collimator manual.*

---













Modifications of, or additions to, the system must be made in accordance with the legal regulations and generally accepted engineering standards.

The manufacturer cannot assume responsibility for the safety features and for the reliability and performance of the equipment, if:

- installation of equipment expansions or modification are not approved by the manufacturer.
- installation of equipment expansions or modification are not carried out by persons authorized by the manufacturer.
- components are not replaced by original spare parts in case of a malfunction.
- the electrical installation of the room concerned does not meet the requirements or the corresponding national regulations.
- the system is not used in accordance with the operating instructions.

### 2.7 Safety and Warning Symbols

The following symbols are used for the system.

	Attention consult accompanying documents.
	To signify a general warning. This symbol is used in various places throughout the Manual where special precaution shall be observed.
	Type B applied part.
	Protective earth terminal.
	Earth terminal.
N	Connection point for the neutral conductor on permanently installed equipment.
	Squeezing hazard.
	This symbol indicates compliance of the equipment with MDR 2017/745 EU.
	Separate collection for electrical and electronic equipment.
	Manufacturer
	Date of manufacture
	To indicate the emission or the imminent emission of X-radiation.
	Marking on the emergency stop button. Activation of the actuator interrupts all mechanical movements and prohibits exposures.

# Safety

## Safety and Warning Labels on the Equipment

### 2.8 Safety and Warning Labels on the Equipment

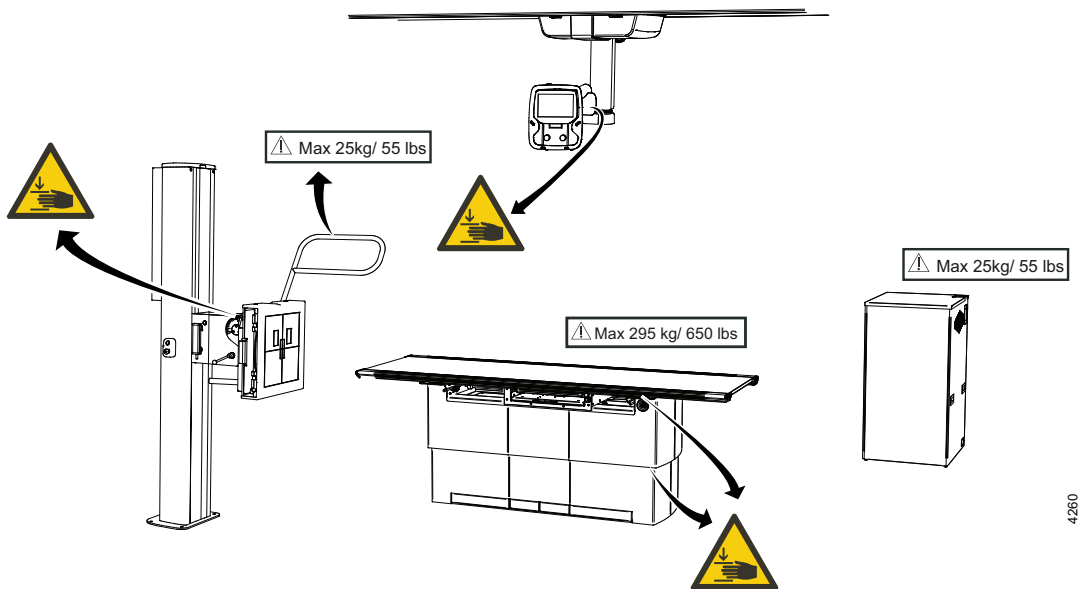

Fig. 2-1 Locations of safety and warning labels

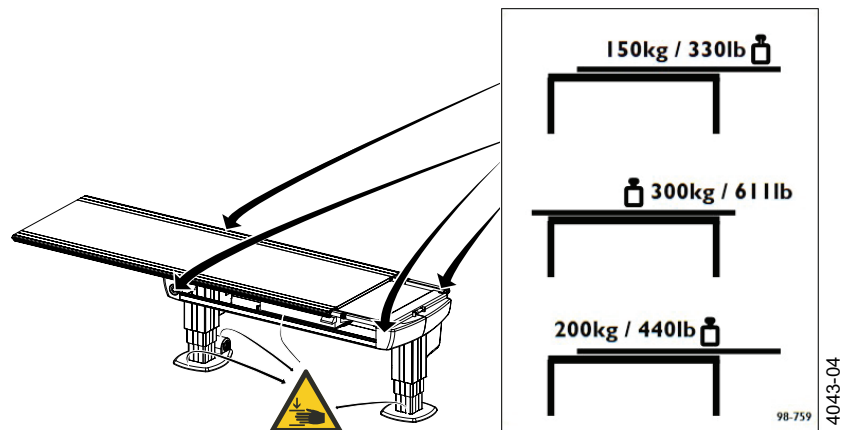
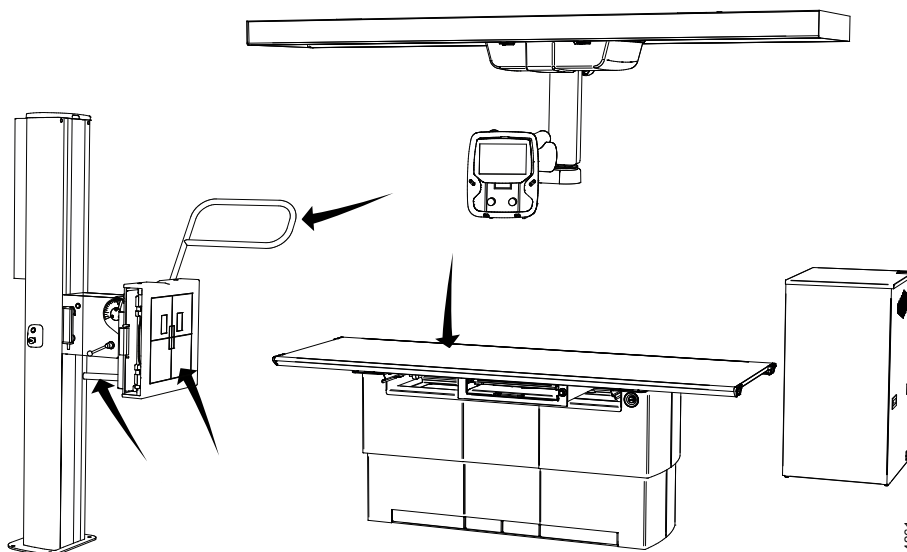

Fig. 2-2 Location of the weight restriction labels and warning labels, table 0055



## 2.9 Applied parts

Applied parts are intended contact surfaces for patients.



*Fig. 2-3 Applied parts*

4261

# Safety

## Essential Performance and Basic Safety

---

### 2.10 Essential Performance and Basic Safety

The essential performance of the system is defined in the particular standard 60601-2-54, clause 201.4

- Accuracy of LOADING FACTORS
- Reproducibility of the RADIATION output
- AUTOMATIC CONTROL SYSTEM
- Imaging performance

These Essential Performances summarize together the functions necessary to obtain the Radiographic Image.

The equipment shall maintain basic safety while performing normal operations. The following degradations associated with basic safety shall not be allowed:

- Initiation of an unintended **non user initiated** motorized movement.
- Initiation and performing a **non user initiated** x-ray exposure.
- A **non user initiated** change of any loading parameter.

The equipment may exhibit temporally functional degradation of performance that does not affect essential performance or basic safety, e.g. caused by EMI (electromagnetic interference). Examples of such temporally functional degradation “degradation can be:

- Error or warning messages warning for a state that does not affect essential performance or basic safety.
- The system can prevent a **user initiated** xray exposure to start if an error is detected that can affect essential performance or basic safety.
- A termination of a **user generated** motorized movement.

### 2.11 Emergency Stop

**Note!**

*It is recommended to train the operator regularly in the use of the emergency stop function so the operator feels confident in using it.*

The system has five internal emergency stops; one on the OTC, one on each side of the table and two on the wallstand.

Pressing one of the emergency stop buttons, immediately cuts the power to all motorized movements. The emergency stop is also connected to the generator. The emergency stop will prevent a new exposure and terminate an ongoing exposure. A system message is displayed in OTC display when the button is activated.

To reset the emergency stop position, turn the emergency stop button clockwise. The button is released and the system is ready for use again.

There are additional external emergency stops as option.

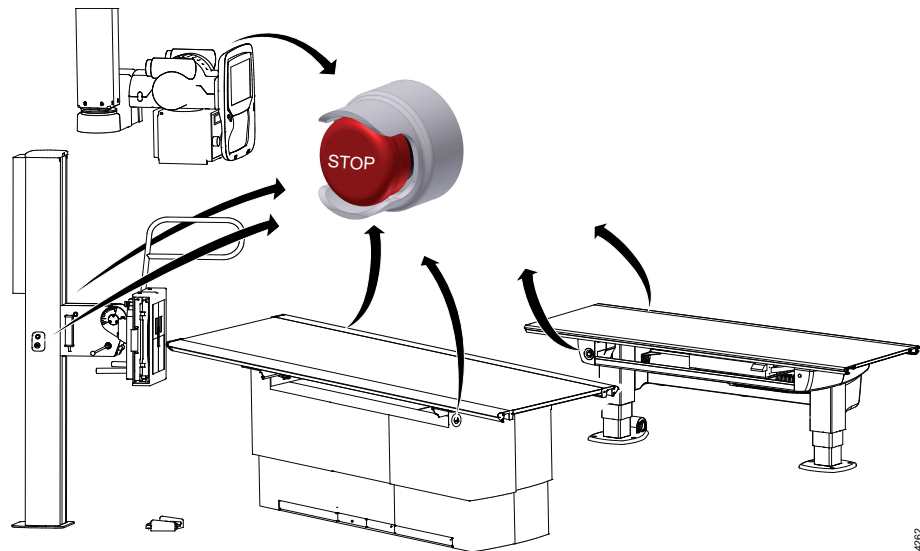

Fig. 2-4 Emergency stops

# Safety

## Radiation and X-ray Tube

---

### 2.12 Radiation and X-ray Tube



**WARNING!**

*The patients, the operators and third parties must be protected against unnecessary X-ray radiation according to the local regulations.*

---



**WARNING!**

*The surfaces on the collimator and the X-ray tube can be warm.  
The X-ray tube may be up to 85 °C, the collimator will not reach 60 °C.*

---



**WARNING!**

*Verify that correct collimator filter is used during exposure.*

---



**WARNING!**

*The SID shown in the display should correspond to SID shown on the collimator.*

---

**CAUTION!**

*To minimize the X-ray dose during the exposure, keep the distance between the tube focal spot and patient as large as possible allowed, considering the clinical application.*

*The beam size should be as small as possible.*

---

**Note!**

*Audio and visual communication must be possible between the operator and the patient when exposure is performed.*

---

**Note!**

*The X-ray beam should not be outside the boundaries of the detector holder.*

---

### 2.12.1 Radiation Protection

Because of the ionizing nature of x-ray radiation, precautions have to be taken to minimize the harmful effects to patients and operators/staff during exposures. The aim is to achieve dose levels “as low as reasonable achievable”. National regulatory dose limitation requirements have to be followed.

Following four main factors control the amount (dose) of radiation received from a source:

Patient and operator dose:

**Loading factors:** Reducing the loading factors reduces the effective dose proportionally. Lower values will give more noise in the image.

**Distance:** Increasing the distance reduces dose levels according to the inverse square law.

**Beam size:** Keep the beam size as small as possible.

**Shielding:** Whenever possible/necessary protective shielding should be used to limit dose levels.

#### 2.12.1.1 Protection Against Primary Radiation (Patient)

Following measures should to be taken to limit patient dose.

- Observe national dose limit regulations.
- Exposure parameters (time/mA) should be set as low as possible with an acceptable image noise level.
- Set focus to skin distance as large as possible.
- Always collimate the exposure field to the area of interest. This will both decrease the dose level and improve the image quality (less scattered radiation).
- If possible/necessary use protective shielding.

#### 2.12.1.2 Protection Against Secondary Radiation

As the patient is the most significant source of scattered radiation during an x-ray exam, the staff and/or operator will unavoidable be exposed to ionizing radiation when inside the x-ray room during an exposure. Radiation doses from scattered radiation can be significantly high. The following safety measures should be taken to minimize scattered radiation to the staff.

- Increase the distance to the central beam to reduce dose levels according to the inverse square law.
- Use protective clothing, e.g. lead apron.
- Set the exposure parameters (time/mA) as low as possible.
- Use high kV and low mA to produce less scatter.
- Collimate the exposure field to the area of interest.
- Add collimator filter to reduce the scatter.
- Compression of patient.

# Safety

## Radiation and X-ray Tube

### Profile of Stray Radiation For Table

The diagram below, **Fig. 2-5**, shows the dependency of the scattered radiation on the distance from the central beam, height above the floor and kV potential. The decrease of the scattered radiation is expressed in percent of the central beam exposure rate (100%). The diagram also shows the decrease of scattered radiation when using protective clothing, also this expressed in percent of the central beam dose rate.

**Fig. 2-5**, shows that a higher kV increases the scattered radiation slightly. The diagram also shows that the best way to minimize the effect of the scattered radiation is an increased distance to the patient and by using a lead apron.

Central beam exposure parameters used:

KVP: 70, 100, 120 kV

Tube current: 100 mA

Exposure time: 100 ms

Field size: 43x43 cm

Film-Focus distance: 1 m

Patient simulation: 150 mm PMMA

Filter: 0 mm

Central beam dose rate measured on top of PMMA (750 mm from focus).

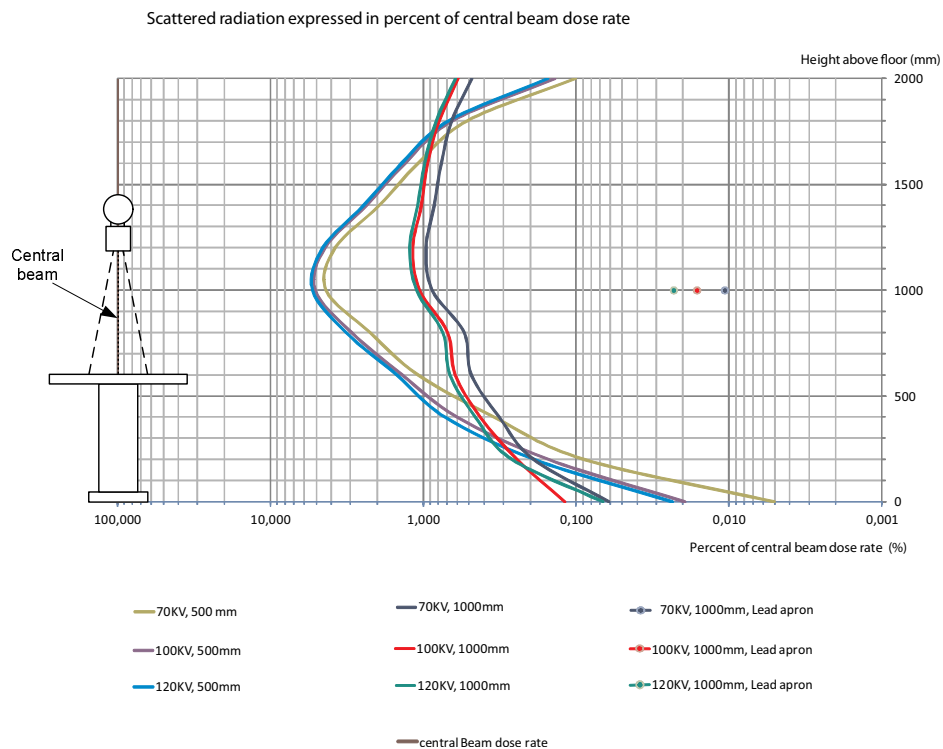

**Fig. 2-5** Scattered radiation rate expressed in percent of central beam dose rate, with and without shielding

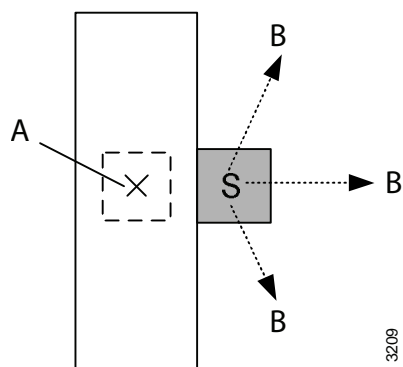

**Fig. 2-6** shows a top view of the table and the zone of occupancy, where the arrows B show the direction of decreasing scatter radiation levels.

*Fig. 2-6 S = Significant zone of occupancy*

*A Central beam*

*B Decreasing*

# Safety

## Radiation and X-ray Tube

### Profile of Stray Radiation For Wallstand

The diagram below, **Fig. 2-7**, shows the dependency of the scattered radiation on the distance from the central beam, height above the floor and kV potential. The decrease of the scattered radiation is expressed in percent of the central beam exposure rate (100%). The diagram also shows the decrease of scattered radiation when using protective clothing, also this expressed in percent of the central beam dose rate.

**Fig. 2-7** shows that a higher kV increases the scattered radiation slightly. The diagram also shows that the best way to minimize the effect of the scattered radiation is with an increased distance to the patient and by using a lead apron.

Central beam exposure parameters:

KVP: 70, 100, 120 kV

Tube current: 100 mA

Exposure time: 100 ms

Field size: 40x40 cm

Film-Focus distance: 1,5 m

Patient simulation: 150 mm PMMA

Filter: 0 mm

Central beam dose rate measured on top of PMMA (1250 mm from focus)

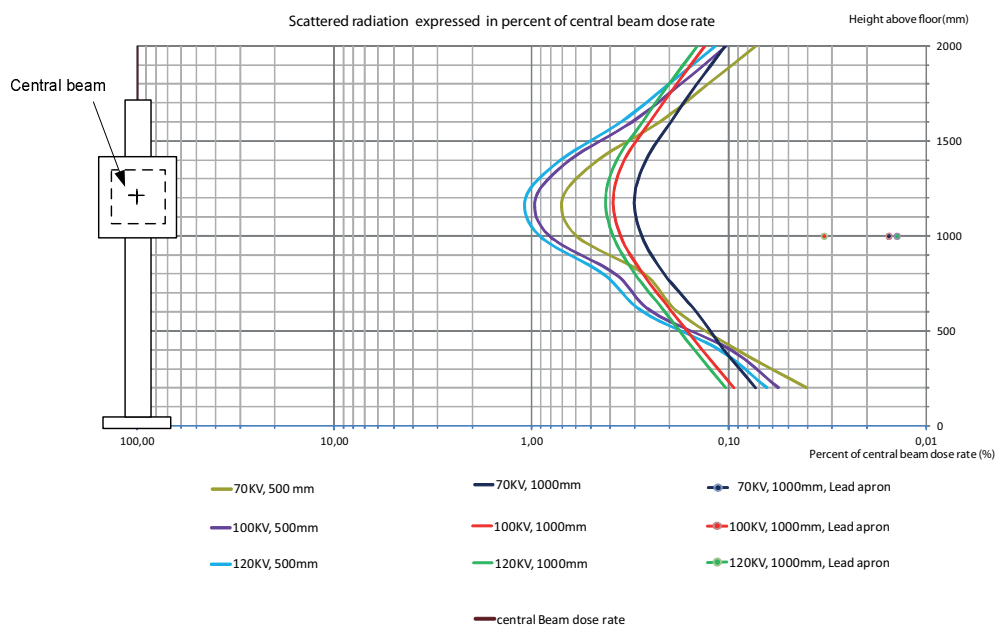

**Fig. 2-7** Scattered radiation rate expressed in percent of central beam dose rate, with and without shielding



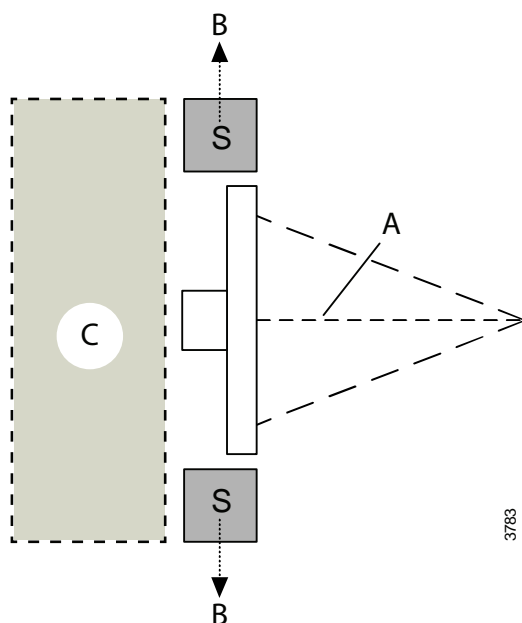

**Fig. 2-8** shows a top view of the wallstand and the zone of occupancy, where the arrows **B** show the direction of decreasing scatter radiation levels.

*Fig. 2-8 S = Significant zone of occupancy*

*A Central beam*

*B Decreasing*

*C Residual radiation area*

### 2.12.1.3 Protection Against Residual Radiation

The remaining part of the X-ray beam after having passed the plane of the image reception area (detector and detector holder) can be significantly high. Never stand behind the wallstand during an exposure, see **Fig. 2-8**.

### 2.13 Mechanical Safety

#### 2.13.1 General



**WARNING!**

*All motorized movements shall be supervised by trained personnel.*

---



**WARNING!**

*Tracking shall be supervised by trained personnel.*

---



**WARNING!**

*Wheelchair patients shall always be placed outside the working area, when operating any motorized movement.*

---

**Note!**

*Surrounding equipment is not subject of the collision warning.*

---

It is the operator's duty to ensure that any danger to the patient or third parties is prevented before the system is operated.

### 2.13.2 Overhead Tube Crane



**WARNING!**

*Squeezing hazard between the overhead crane and wallstand respective between the overhead tube crane and table.*

*The operator should be beside the patient for support to avoid any risk of injury when handling the overhead tube crane.*

---



**WARNING!**

*Squeezing hazard can occur between column segments and beta rotational assembly interface.*

---



**WARNING!**

*Squeezing hazard can occur between the column and the plastic corner around the alpha movement.*

---



**WARNING!**

*Squeezing hazard can occur between support arm and high tension cable inlet to the tube.*

---

**CAUTION!**

*The IR sensor (option) underneath the OTC is exclusively intended for table protection.*

*It is not intended for patient protection.*

---

# Safety

## Mechanical Safety

---

Possible squeezing hazard areas and placement of warning label:

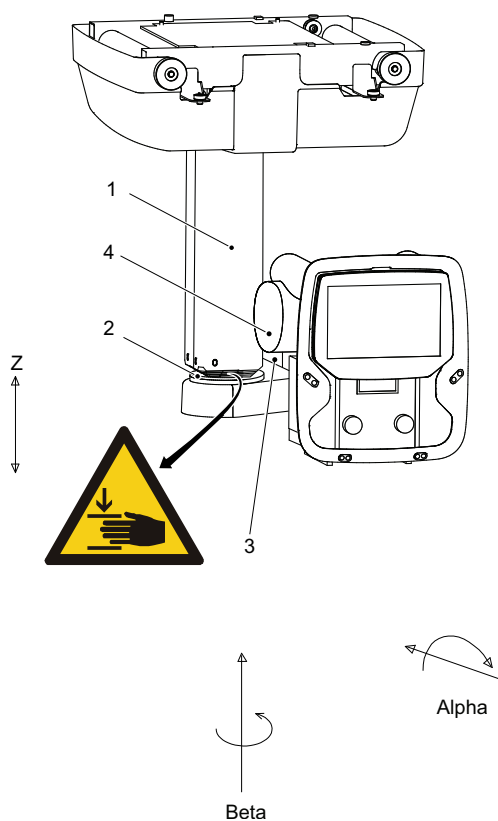

Fig. 2-9 OTC, mechanical safety

- |                        |               |
|------------------------|---------------|
| 1. Column (Z)          | 3. Cover      |
| 2. Column bottom plate | 4. X-ray tube |

Squeezing hazard can occur between the:

- column (Z) and the column bottom plate when the column is moving upward (Z-direction).
- cover and the column (Z) when the X-ray tube is moving in beta direction.

**2.13.3 Cabinet**

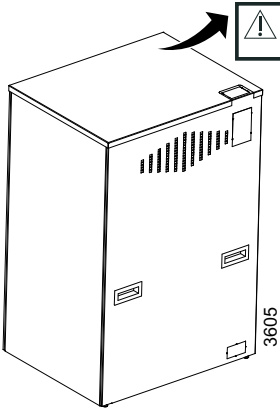

⚠ Max 25kg/ 55 lbs

Cabinet, mechanical safety  
Max 25 kg/ 55 lbs

*Fig. 2-10 Placement of warning and safety label.*

### 2.13.4 Table



#### **WARNING!**

---

*Squeezing hazard can occur between the:*

- *table top and the top of the detector holder*
  - *table top and the detector holder rail*
  - *detector holder rail and the detector holder*
  - *detector holder and the cover*
  - *vertical lift segments when moving down in Z-direction (closed table)*
  - *columns and the footplate (two column table)*
  - *cover and the column foot cover*
  - *detector holder and vertical lift segment*
- 

Possible squeezing hazard areas and placement of warning labels:

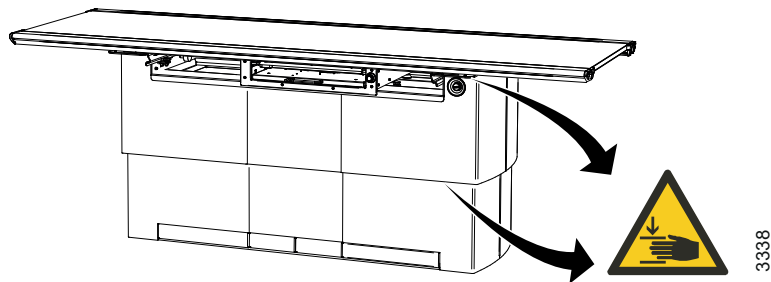

Fig. 2-11 Closed table

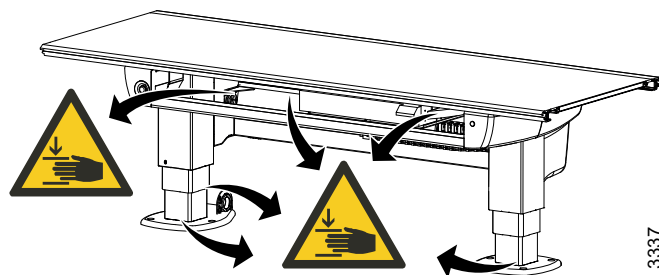

Fig. 2-12 Two column table (option)

**2.13.4.1 Safety Issues when Positioning a Patient**



**WARNING!**

*Be aware of unwanted motion when releasing the brakes.*

---



**WARNING!**

*Risk of injury during transfer of the patient between the hospital bed and the table.  
The hospital bed shall be placed in direct contact with and at the same height as the table.  
The table top shall be locked.*

---



**WARNING!**

*Risk of squeezing hazards.  
The patients shall always have their extremities placed over the table top.*

---



**WARNING!**

*Wheelchair patients shall always be placed outside the working area, when operating any motorized movement.*

---

**Note!**

*Do not lean against the floating table top.*

---

# Safety

## Mechanical Safety

---

Lock and center the table top when transferring the patient to the table.

The hospital bed shall always be placed in direct contact and in the same height as the table.

To reduce the lateral forces on the table the operator should be placed on the opposite longitudinal side of the patient and the hospital bed. The operator (**A**) should drag the mattress with the patient from the hospital bed to the table.

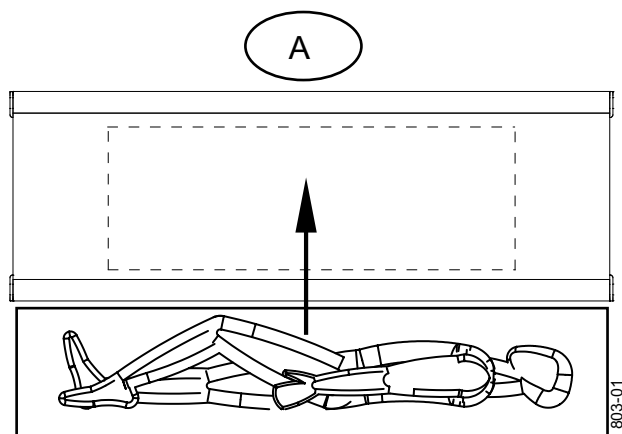

Fig. 2-13 Transfer patient to table by operator A



**Patient Weight Restrictions**  
**Table Top Centered**

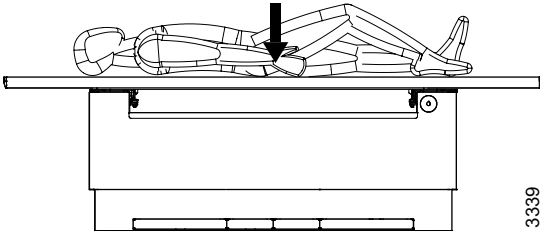

Fig. 2-14 Table top centered

<b>Type</b>	<b>Maximum patient weight</b>
Closed table	295 kg/ 650 lb
Two column table	300 kg/ 661 lb

**Table Top Outside Table Frame**

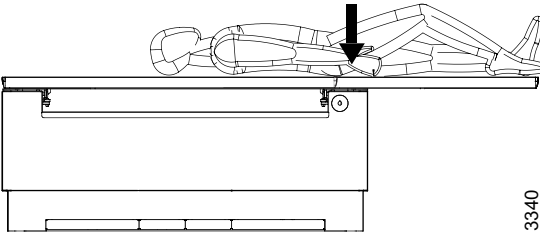

Fig. 2-15 Table top outside table frame

<b>Type</b>	<b>Maximum patient weight</b>
Closed table	200 kg/ 440 lb
Two column table	200 kg/ 440 lb

The table frame is marked with the maximum weight when positioning in outer positions.

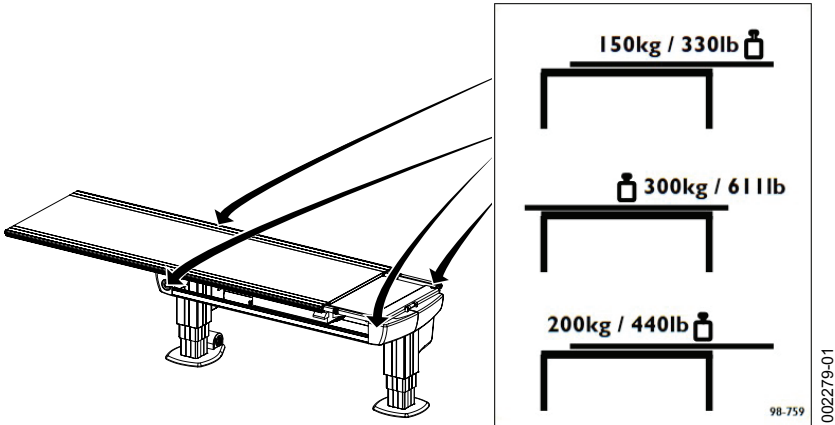

Fig. 2-16 Maximum patient weight label

# Safety

## Mechanical Safety

---

### 2.13.4.2 Working Area, Table



#### **WARNING!**

---

*Risk of squeezing hazard.*

*Patients shall be outside the working area or placed on the table, when operating any motorized movement.*

---



#### **WARNING!**

---

*Risk of squeezing hazard.*

*All obstacles placed within the working area, must be moveable for easy patient release.*

---

#### **CAUTION!**

---

*To avoid any injuries to patient, user or damage to system, peripherals should always be placed outside the working area.*

---

The working area comprises the table top including the stroke length of the table top in the X- and Y-direction. The measurements in the figure show the length of stroke in the X- and Y-direction. The dimensions have some tolerances and can differ from the manufacturer's.

### Closed Table

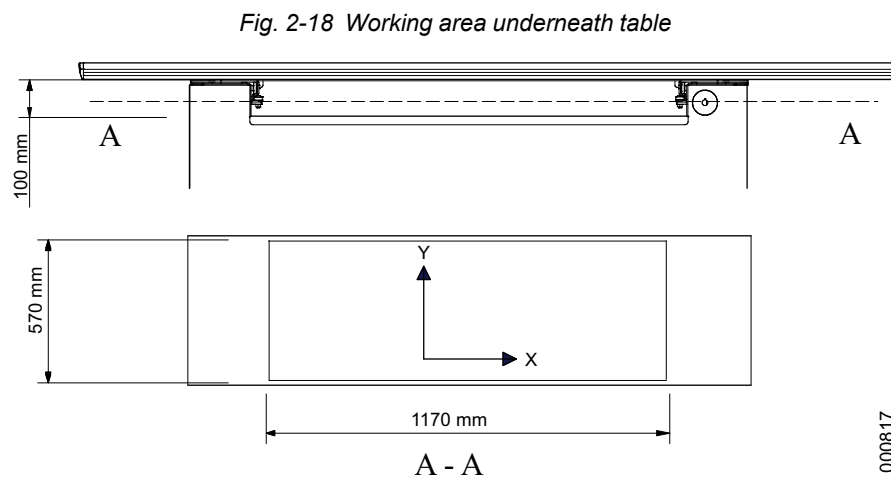
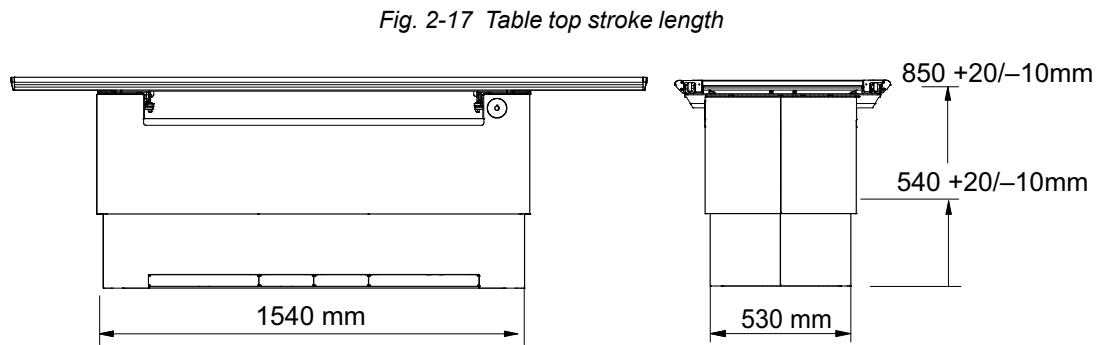
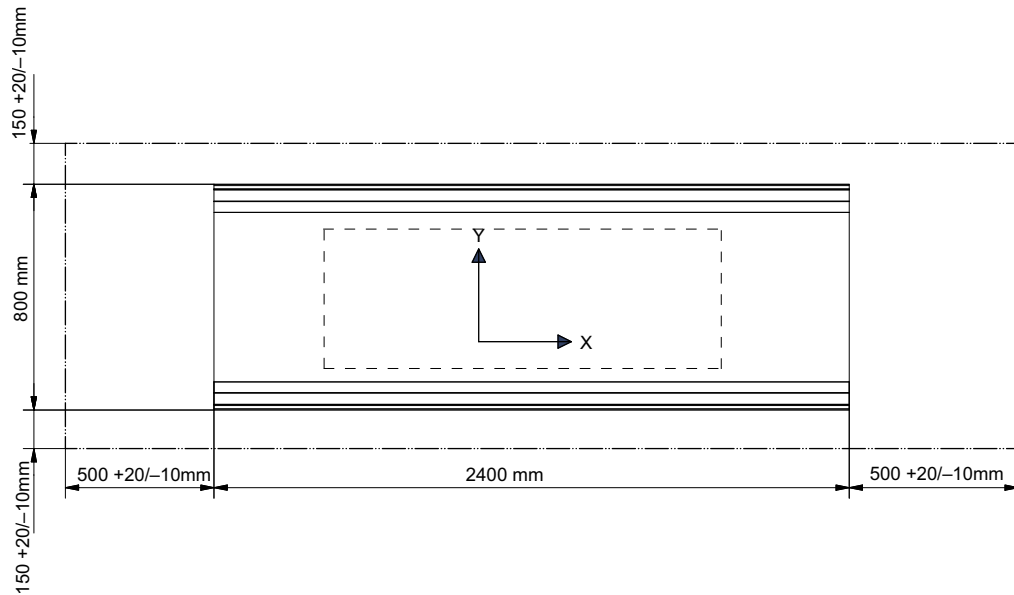

000817

### Two Column Table (option)

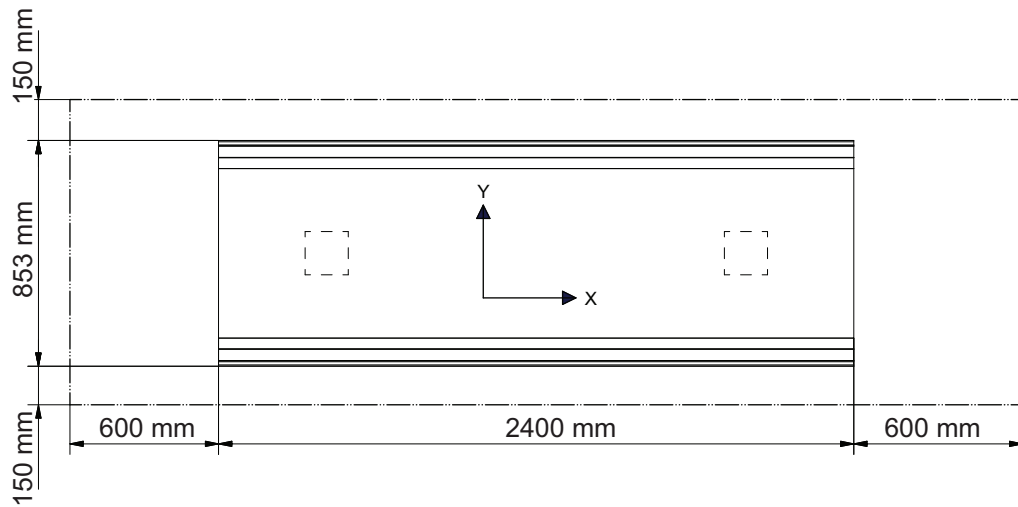

Fig. 2-20 Table top stroke length

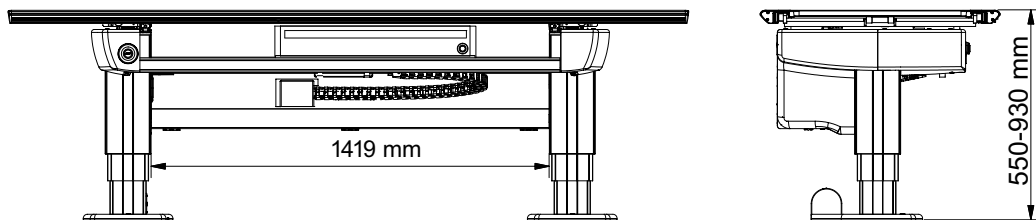

Fig. 2-21 Working area underneath table

The detector movement is up to 850 mm, depending on detector type.

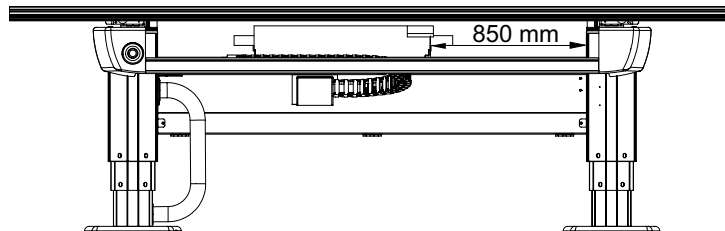

Fig. 2-22 Detector movement

### 2.13.5 Wallstand

#### 2.13.5.1 Safety Issues When Positioning Patient



#### **WARNING!**

***Be aware of unwanted motion when releasing the brakes.***

---

#### **Note!**

*Maximum weight on the wallstand lateral armrest is 25 kg/ 55 lbs.*

---

#### 2.13.5.2 Working Area, Wallstand

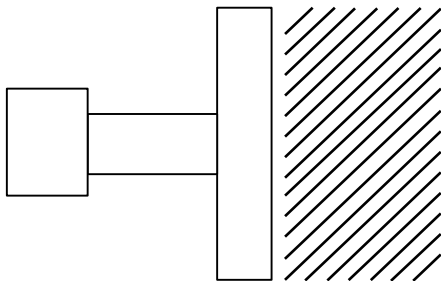

The working area of the wallstand is the area in front of the detector holder

3784

Fig. 2-23 Working area, wallstand

# Safety

## Mechanical Safety

---

### 2.13.5.3 Standard Version Wallstand



**WARNING!**

**Risk of squeezing between the tilted image receptor holder and the floor.**

---

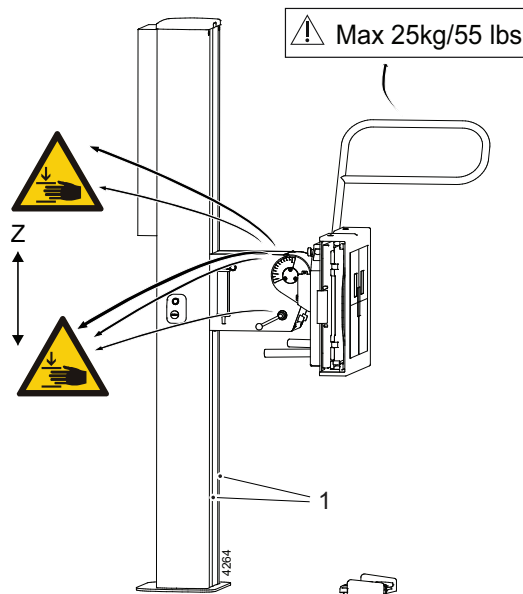

Getting stuck in the slide opening (1) is a squeezing hazard when the detector holder is moving downward (Z-direction)

Possible squeeze hazard areas and placement of warnings and safety labels, see **Fig. 2-24**

The system is balanced with counterweights and whenever any item is removed from the wallstand it becomes unbalanced. If the brake is released when the wallstand is unbalanced, the detector holder moves and can cause injury.

Fig. 2-24 Possible squeeze hazards

1. Slide opening of detector wagon

### 2.13.5.4 Motorized Wallstand

**CAUTION!**

**Patients shall be outside the working area when operating any motorized movement.**

---

## 2.14 Safety Functions

### 2.14.1 Opposite Buttons Pressed

If, at any time, two from each other opposite buttons are pressed, for example movements up and down, the movement is stopped. Both buttons must be released before any movement is allowed.

### 2.14.2 Dead Man's Grip

All movements require constant activation of the chosen button.

If the operator releases one of the buttons/controls, the system will immediately stop or engage the brakes (manual movements). The exposure operator console has the same functionality.

### 2.14.3 Watchdog

One important issue for the safety in the system is the node error handling e.g. transmission error, software error or irregular behaviour of a node. The system is built to prevent an uncontrolled movement.

### 2.14.4 Two Column Table (option)

#### 2.14.4.1 Table Top Guard (option)

The table has a collision detection system that protects the table. It activates if a collision is detected and all movement is stopped.

### 2.14.5 Closed Table

#### 2.14.5.1 Vertical Travel (Z-Movement) Safety

The table has a vertical travel safety system to protect the table top. When the table top collide with something, the Z-movement will stop. You will have to push a button (kick box control/manoeuvre hand control/foot control) in either direction to be able to move the table again.

When a collision in Z-direction is detected, the stand has to be moved in the opposite direction before it can be moved in the original direction again.

#### 2.14.5.2 Indication of Power to the Table

The device is powered when the green indicator light (A) on the table frame is lit.

*Note!*

*When no power, the usability of the table is highly limited.*

---

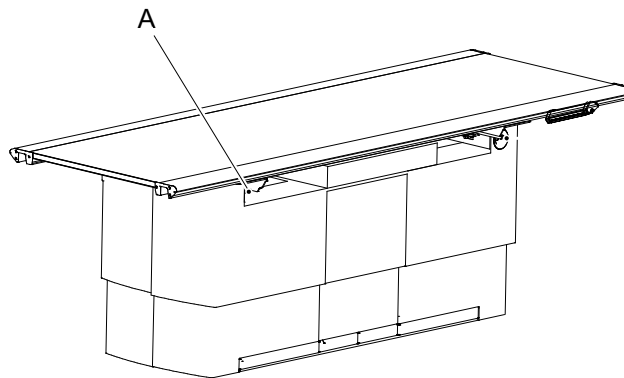

Fig. 2-25



### 2.14.6 Wallstand

The product is balanced with counterweights and whenever any item is removed from the wallstand it becomes unbalanced. If the brake is released when the wallstand is unbalanced, the detector holder moves and can cause injury.

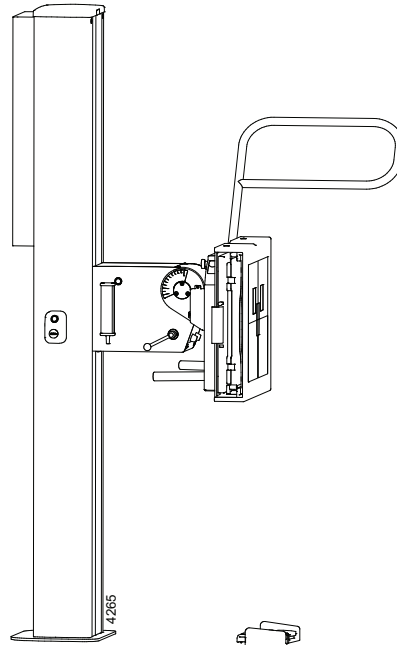

Fig. 2-26 Wallstand



#### **WARNING!**

---

***Be aware of unwanted motion when releasing the brakes.***

---

#### 2.14.6.1 Manual Wallstand

The wallstand is strictly manually controlled. All movements are balanced which means that very little force needs to be applied. To move the system up or down, the brake has to be released, by pressing constantly and pushing the detector holder manually up or down.

#### 2.14.6.2 Motorised Wallstand

##### ***Collision Detection***

Every motorized movement has a collision detection. All movements are stopped when the collision detection is activated and the display shows an error message.

# Safety

## IT- and Cyber Security

---

### 2.15 IT- and Cyber Security

CXDI NE does not support any specific security measures. It is assumed that CXDI NE is used within a secured environment. It is assumed that a secured environment includes at a minimum:

- Firewall or router protections to ensure that only approved external hosts have network access.
- Firewall or router protections to ensure that CXDI NE only has network access to approved external hosts and services.
- Any communication with external hosts and services outside the locally secured environment use appropriate secure network channels (e.g., VPN).

Other network security procedures such as automated intrusion detection may be appropriate in some environments. Additional security features may be established by the local security policy. No equipment other than what is delivered with the product should be connected to the computer.

## 2.16 Safety Zone, Definition

At installation, a safety zone is defined.

The intention of the safety zone is to prevent collision with the patient during tracking downwards. When the lowest part of the overhead tube crane (OTC) is above the safety zone, tracking is possible. When it is inside the safety zone, tracking is not possible.

The safety zone does not affect the function of the manual movement (no tracking) or tracking upwards.

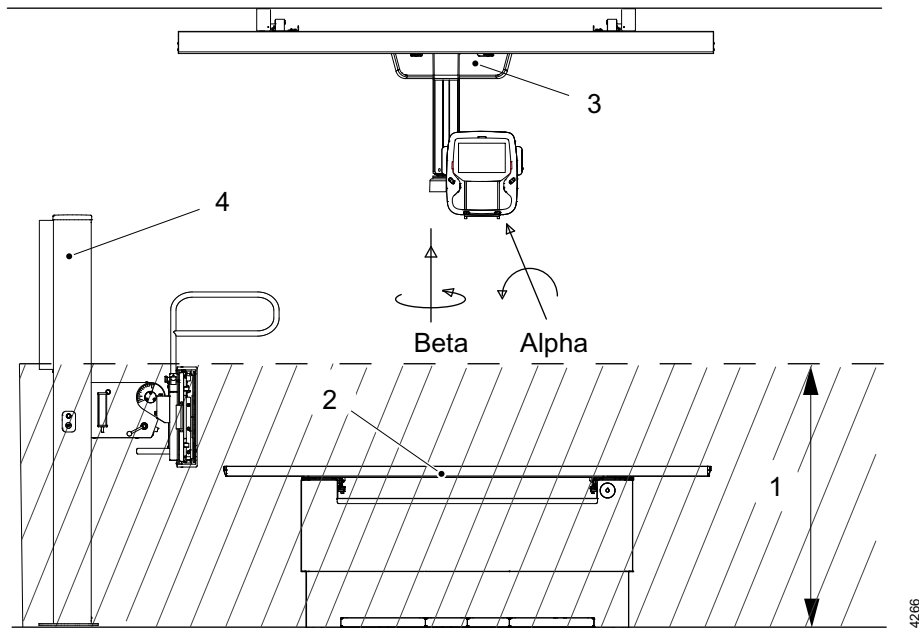

- |                |              |
|----------------|--------------|
| 1. Safety zone | 3. OTC       |
| 2. Table       | 4. Wallstand |

### 2.16.1 Table

Tracking downwards is not possible in the safety zone.

The safety zone does not affect the function of tracking upwards.

### 2.16.2 Wallstand

When the alpha angle is outside the range of  $+45^\circ$  to  $-45^\circ$ , tracking is possible in safety zone.

# Safety

## Electromagnetic Compatibility (EMC)

---

### 2.17 Electromagnetic Compatibility (EMC)

The system complies with the requirements of IEC 60601-1-2:2014 regarding electromagnetic compatibility. Surrounding equipment shall follow the standard IEC 60601-1-2:2014.



---

**WARNING!**

*Do not use this equipment adjacent to or stacked with other equipment. Such use could lead to improper operation. Verify that the equipment is operating normally, if such use is necessary.*

---



---

**WARNING!**

*Do not use other accessories, transducers and cables than those specified or provided by the manufacturer. Such use could lead to increased electromagnetic emissions or decreased electromagnetic immunity of this equipment and result in improper operation.*

---



---

**WARNING!**

*Do not use portable RF communications equipment (including peripherals such as antenna cables and external antennas) closer than 30 cm (12 inches) to any part of the system, including cables specified by the manufacturer. Such use could lead to degradation of the performance of this equipment.*

---

---

**CAUTION!**

*Do not place the system near MRI equipment or other equipment that generates a strong magnetic field.*

---

---

**CAUTION!**

*Mobile telephones and other radiating equipment can interfere with the function of the system and can therefore cause safety hazards.*

---

# Safety

## Electromagnetic Compatibility (EMC)

---

The system is intended for use in the electromagnetic environment specified below. The customer or the user of the system should assure that it is used in such an environment.

<b>Guidance and manufacturer's declaration - electromagnetic emissions</b>		
<b>Emissions test</b>	<b>Compliance</b>	<b>Electromagnetic environment - guidance</b>
RF emissions CISPR 11	Group 1	The system uses RF energy only for its internal function. Therefore, its RF emissions are very low and are not likely to cause any interference in nearby electronic equipment.
RF emissions CISPR 11	Class A	The emissions characteristics of this equipment make it suitable for use in industrial areas and hospitals (CISPR 11 class A). If it is used in a residential environment (for which CISPR 11 class B is normally required) this equipment might not offer adequate protection to radio-frequency communication services. The user might need to take mitigation measures, such as relocating or re-orienting the equipment.
Harmonic emissions IEC 61000-3-2	Not applicable	
Voltage fluctuations/ Flicker emissions IEC 61000-3-3	Not applicable	

<b>Guidance and manufacturer's declaration - immunity</b>	
Immunity test level	<b>Professional healthcare facility environment</b>

# Safety

## Electromagnetic Compatibility (EMC)

The system is intended for use in the electromagnetic environment specified below. The customer or the user of the system should assure that it is used in such an environment.

<b>Guidance and manufacturer's declaration - electromagnetic emissions</b>			
<b>Emissions test</b>	<b>IEC 60601 test level</b>	<b>Compliance level</b>	<b>Electromagnetic environment - guidance</b>
Radiated emissions CISPR 11	30 MHz to 230 MHz: QP 40  230 MHz to 1 GHz: QP 47	30 MHz to 230 MHz: QP 40  230 MHz to 1 GHz: QP 47	
Conducted emissions CISPR 11	150 kHz to 500 kHz: QP 100+20, average 90  500 kHz to 5 MHz: QP 86+20, average 76  5 MHz to 30 MHz: QP 90+20 (at 5 MHz) decreasing linearly to 73+20 (at 30 MHz)  average 80 (at 5 MHz) decreasing linearly to 60 (at 30 MHz)	150 kHz to 500 kHz: QP 100+20, average 90  500 kHz to 5 MHz: QP 86+20, average 76  5 MHz to 30 MHz: QP 90+20 (at 5 MHz) decreasing linearly to 73+20 (at 30 MHz)  average 80 (at 5 MHz) decreasing linearly to 60 (at 30 MHz)	Note: Use of the increased +20 dB relaxed limits was not needed during the test.
Note: These limits apply to equipment with a rated power > 20 kVA and intended to be connected to a dedicated power transformer or generator, and which is not connected to low voltage (LV) overhead power lines. 20 dB relaxation for Quasi-Peak (QP) is allowed for Radiography and pulsed Radiography (Intermittent Mode).			

The system is intended for use in the electromagnetic environment specified below. The customer or the user of the system should assure that it is used in such an environment.

<b>Guidance and manufacturer's declaration - electromagnetic immunity</b>			
<b>Immunity test</b>	<b>IEC 60601 test level</b>	<b>Compliance level</b>	<b>Electromagnetic environment - guidance</b>
Electrostatic discharger (ESD) IEC 61000-4-2	± 8 kV contact ± 15 kV air	± 8 kV contact ± 15 kV air	Floors should be wood, concrete or ceramic tile. If floors are covered with synthetic material, the relative humidity should be at least 30%.
Electrical fast transient/burst IEC 61000-4-4	± 2 kV for power supply lines ± 1 kV for input/output lines 100 kHz repetitive frequency	± 2 kV for power supply lines ± 1 kV for input/output lines 100 kHz repetitive frequency	Mains power quality should be that of a typical commercial or hospital environment.
Surge IEC 61000-4-5	± 0.5 kV ± 1.0 kV ± 2.0 kV 0,90, 180, 270 degree phase angle	± 0.5 kV ± 1.0 kV ± 2.0 kV 0,90, 180, 270 degree phase angle	Mains power quality should be that of a typical commercial or hospital environment.
Voltage dips, short interruptions and voltage variations on power supply input lines. IEC 61000-4-11	<5 % $U_T$ (>95 % dip in $U_T$ ) for 0.5 cycle (0, 45, 90, 135, 180, 225, 270, and 315 degrees phase angle) <5% $U_T$ (>95% dip in $U_T$ for 1 cycle) 70% (30 % dip in $U_T$ for 25/30 cycles) <5 % $U_T$ (>95 % voltage dip in $U_T$ for 250/300 cycles)	<5 % $U_T$ (>95 % dip in $U_T$ ) for 0.5 cycle (0, 45, 90, 135, 180, 225, 270, and 315 degrees phase angle) <5% $U_T$ (>95% dip in $U_T$ for 1 cycle) 70% (30 % dip in $U_T$ for 25/30 cycles) <5 % $U_T$ (>95 % voltage dip in $U_T$ for 250/300 cycles)	Mains power quality should be that of a typical commercial or hospital environment. If the user of the system requires continued operation during power mains interruptions, it is recommended that the system should be powered from an uninterrupted power supply or battery.
<b>Note!</b>			
$U_T$ is the AC mains voltage prior to application of the test level.			

# Safety

## Electromagnetic Compatibility (EMC)

Guidance and manufacturer's declaration - electromagnetic immunity			
Immunity test	IEC 60601 test level	Compliance level	Electromagnetic environment - guidance
			<p>Portable and mobile RF communications equipment should be used no closer to any part of the system, including cables, than the recommended separation distance, calculated from the equation applicable to the frequency of the transmitter.</p> <p>Recommended separation distance:</p>
Conducted RF IEC 61000-4-6	3 Vrms 150 kHz to 80 MHz 6 Vrms (ISM bands)	3 Vrms 150 kHz to 80 MHz 6 Vrms (ISM bands)	$d = 1.2 \sqrt{p}$
Radiated RF IEC 61000-4-3  Only the most relevant sides containing wiring and electronics were exposed. For more information see EMC report.	3 V/m 10 V/m 80 MHz to 2.7 GHz	3 V/m 10 V/m 80 MHz to 2.7 GHz	$d = 1.2 \sqrt{p}$ 80 MHz to 800 MHz $d = 2.3 \sqrt{p}$ 800 MHz to 2.7 GHz  where $p$ is the maximum output power rating of the transmitter in watts (W) according to the transmitter manufacturer and $d$ is the recommended separation distance in metres (m).
Proximity field from wireless transmitters 61000-4-3	9 V/m to 28 V/m 15 specific frequencies	9 V/m to 28 V/m 15 specific frequencies	For more information, see table 9 in IEC 60601-1-2:2014+A1:2020.
			Interference may occur in the vicinity of equipment marked with the following symbol: 
<p>Note 1: These guidelines may not apply in all situations. Electromagnetic propagation is affected by absorption and reflection from structures, objects and people.</p>			



Test frequency	Modulation	IMMUNITY TEST LEVEL (A/m)
30 kHz <sup>a)</sup>	CW	8
134,2 kHz	Pulse modulation <sup>b)</sup> 2,1 kHz	65 <sup>c)</sup>
13,56 MHz	Pulse modulation <sup>b)</sup> 50 kHz	7,5 <sup>c)</sup>

<sup>a)</sup> This test is applicable only to ME EQUIPMENT and ME SYSTEMS intended for use in the HOME HEALTHCARE ENVIRONMENT.

<sup>b)</sup> The carrier shall be modulated using a 50 % duty cycle square wave signal.

<sup>c)</sup> r.m.s., before modulation is applied.

### Recommended separation distances between portable and mobile RF communications equipment and system

The system is intended for use in an electromagnetic environment in which radiated RF disturbances are controlled. The customer or the user of the system can help prevent electromagnetic interference by maintaining a minimum distance between portable and mobile RF communications equipment (transmitters) and the system as recommended below, according to the maximum output power of the communications equipment.

Rated maximum output power of transmitter <i>W</i>	Separation distance according to frequency of transmitter		
	150 kHz to 80 MHz $d = 1.17 \sqrt{p}$	80 MHz to 800 MHz $d = 0.35 \sqrt{p}$	800 MHz to 2.7 GHz $d = 0.7 \sqrt{p}$
0.01	0.12	0.04	0.07
0.1	0.37	0.11	0.22
1	1.17	0.35	0.7
10	3.69	1.11	2.21
100	11.67	3.5	7

For transmitters rated at a maximum output power not listed above, the recommended separation distance *d* in metres (m) can be estimated using the equation applicable to the frequency of the transmitter, where *p* is the maximum output power rating of the transmitter in watts (W) according to the transmitter manufacturer.

Note 1: These guidelines may not apply in all situations. Electromagnetic propagation is affected by absorption as reflection from structures, objects and people.

# Safety

## Electromagnetic Compatibility (EMC)

---

## 3 User Interfaces

### 3.1 Description

The system is operated from interfaces inside the examination room and from the operating room.

# User Interfaces

## Overhead Tube Crane

### 3.2 Overhead Tube Crane

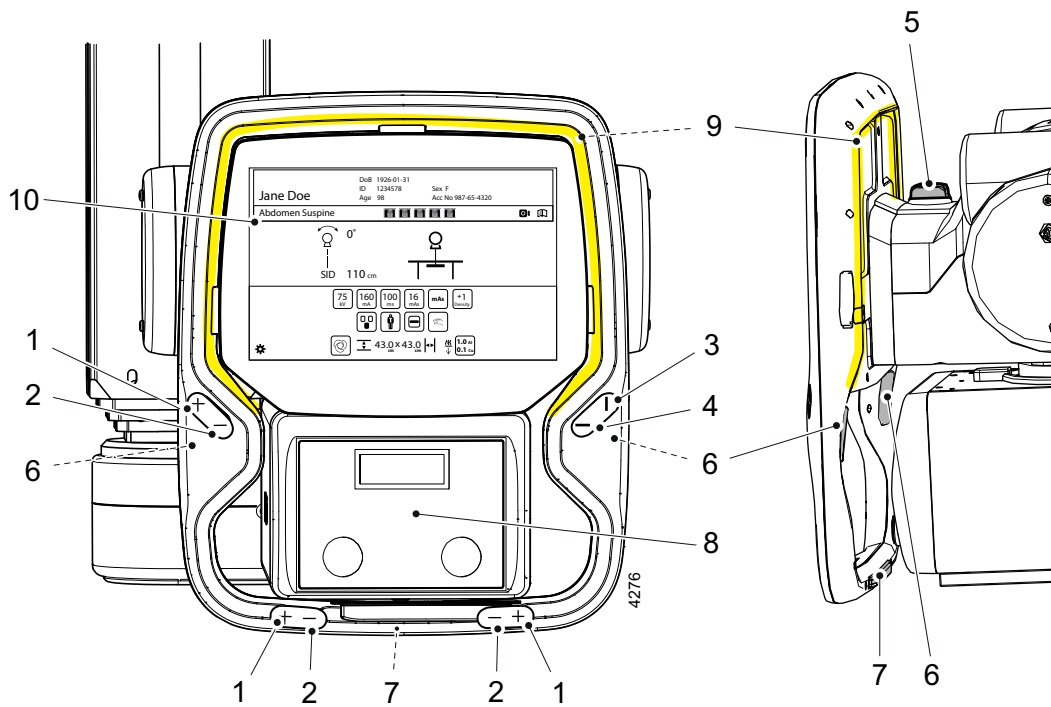

Fig. 3-1

1. Up
2. Down
3. Y direction
4. X Direction
5. Emergency brake (rear side)
6. Alpha-Beta rotation release (rear side)
7. X-Y direction release (rear side)
8. Automatic collimator (option), see 3.6
9. Light indication, see 3.2.11
10. Display user interface, see Fig. 3-2

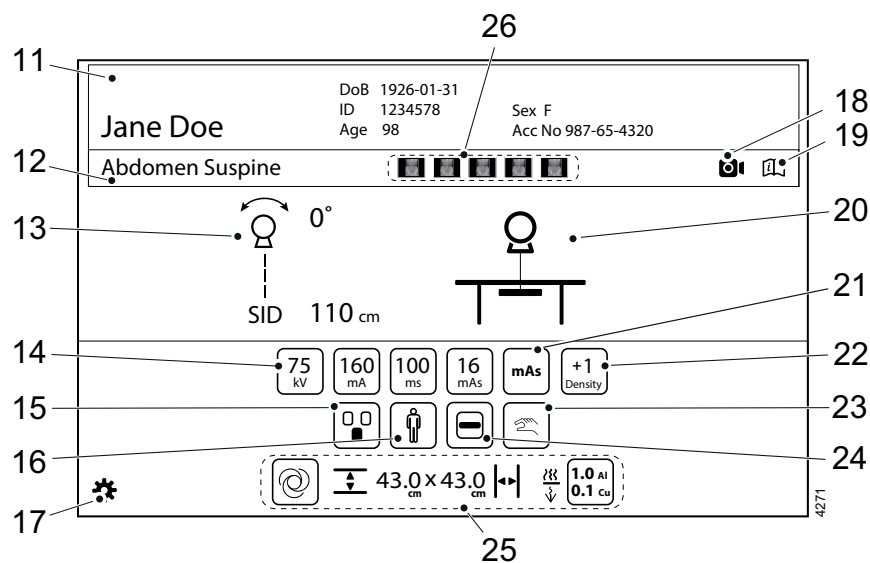

Fig. 3-2

- 11. Patient information
- 12. Active anatomical protocol
- 13. Position information
- 14. Adjustment of generator parameters: kV, mA, ms, mAs, Density
- 15. Selection of active AEC field (AEC mode only)
- 16. Patient size
- 17. Settings and Service menu
- 18. Live camera
- 19. Hospital method book
- 20. Workstation mode
- 21. Selection of exposure mode (AEC, mAs)
- 22. Adjustment of density
- 23. Automatic tracking activation: wallstand and table
- 24. Collimator centering
- 25. Automatic collimator adjustment (option)
- 26. Preview image

# User Interfaces

## Overhead Tube Crane

### 3.2.1 Patient Information

**Note!**

All display patient information must be confirmed at the image system.

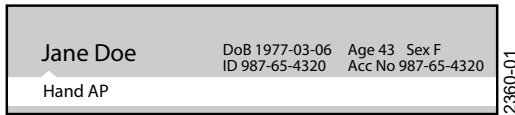

Fig. 3-3 Patient information always shown

The following information can be shown in the Patient Information field:

- Patient Name
- Patient ID
- Date of Birth
- Age, Sex
- Accession number

The information shown is defined in the *Setting menu*. In the *Setting menu* it is also possible to decide if the *Patient information* shall be shown always as in **Fig. 3-3** or on demand as in **Fig. 3-4**.



Fig. 3-4 Patient information shown on demand

When the button is shown on demand, the *Patient information* can be obtained by pushing the "i" on the black bar.

The *Patient information* closes automatically, or when the bar is pushed once again.

### 3.2.2 Position Information

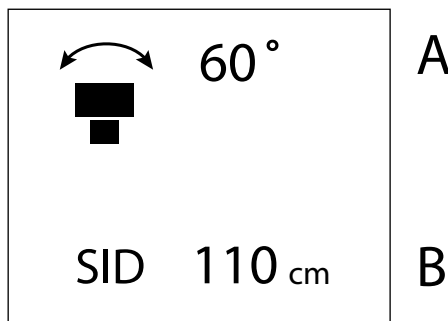

Fig. 3-5 Position information

A Alpha angle (°)

B Source Image Distance (SID), or Height to floor (H) (cm/inch).

A value for SID is shown for tracking table and tracking wallstand toward a horizontally placed detector (tube alpha between -45 degrees and + 45 degrees). The height, focus point to the floor, is shown when tracking is not active.

### 3.2.3 Workstation Mode

The *Workstation* is selected on the OTC display or in the Canon image system.

One of the following symbols is shown on the display:

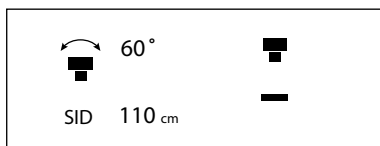

Fig. 3-6 Portable

Portable workstation is selected. Free technique examinations with wireless DR detector.

Only wireless DR detector can be used.

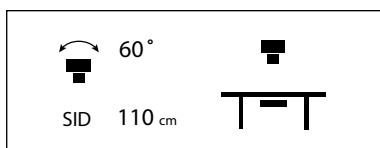

Fig. 3-7 Table

Only table imaging unit/detector holder can be used.

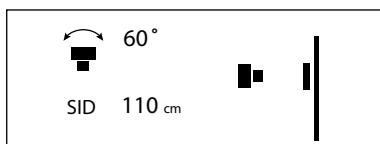

Fig. 3-8 Wallstand

Only wallstand imaging unit can be used.

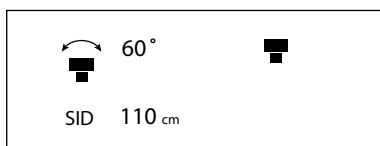

Fig. 3-9 Detector

Detector. Free technique examination.

# User Interfaces

## Overhead Tube Crane

### 3.2.3.1 Automatic Tracking Activation

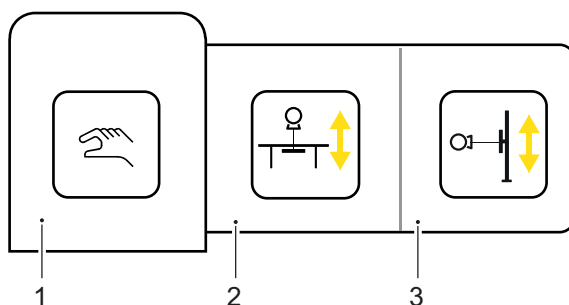

Fig. 3-10 Tracking activation

1. No Tracking activated: Workstation mode is shown (portable, table, wallstand, detector)
2. Auto Tracking, Table
3. Auto Tracking, Wallstand

#### Auto Tracking, Table

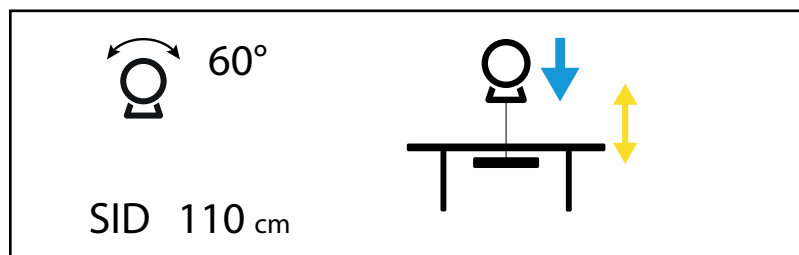

Fig. 3-11 Auto tracking table

1. Press *Automatic Tracking Activation button* in the display and select *Table*, #2, see **Fig. 3-10**.
2. The *Auto tracking, table* icon is shown on the OTC display, see **Fig. 3-11**.
3. A blue arrow will indicate the direction of movement of the OTC to reach the correct SID, see **Fig. 3-11**.
4. Press OTC up or OTC down button (directed by blue arrow) to align. The OTC will stop when the correct position is reached, and the blue arrow will no longer be shown in the display. There will also be a sound signal when the correct position is reached.  
Indication light around the OTC display will change from yellow to green (if all other requirements are fulfilled for exposure; for example detector in position etc.).

#### Auto Tracking, Wallstand

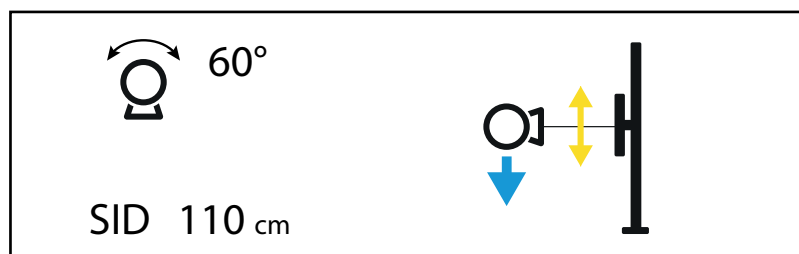

Fig. 3-12 Auto tracking, wallstand

1. Press *Automatic Tracking Activation button* and select *Wallstand*, #3, see **Fig. 3-10**.
2. The *Auto Tracking, Wallstand* icon is shown on the OTC display, see **Fig. 3-12**.



3. Two alternatives are available for the next step.

Alternative 1:

Press OTC up or OTC down button (directed by blue arrow) to align. The OTC will move until the correct position is reached, and the blue arrow will no longer be shown in the display. There will also be a sound signal when the correct position is reached.

Indication light around the OTC display will change to green and the servo button light on the Wallstand will change from flashing to fixed light.

Alternative 2:

Press Servo button on the Wallstand console to align OTC with the Wallstand detector.

Indication light around the OTC display will change to green and the servo button light on the Wallstand will change from flashing to fixed light.

# User Interfaces

## Overhead Tube Crane

---

### 3.2.4 Adjustment of Generator Parameters (kV, mA, ms, mAs)



- Push the button with the parameter that shall be changed to change the exposure values.
- Press +/- to increase/ decrease the value.

*Fig. 3-13 Adjustment of generator parameters*

---

#### **Note!**

*The Operator/User is always responsible for checking and validating the exposure parameters in the Image system before performing exposure.*

---

### 3.2.5 Selection Of Technique Mode

There are three different technique modes available that are selected by pushing the *Technique mode selection* button. The selected mode is highlighted and the pop-up window closes automatically.

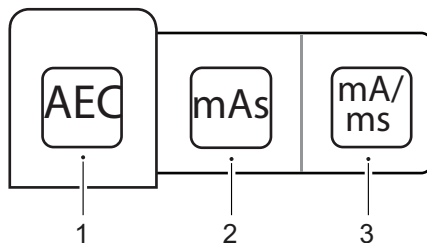

Fig. 3-14 Technique mode selection

1. AEC mode
2. mAs mode
3. mA/ms mode

Depending on what mode is active, different parameters are available. Parameters that are not available for selection are grayed out.

In *AEC mode*, the value used as back-up value (ms, mAs or fixed) is indicated with the text *AEC Backup*.

For more detailed information about the different technique modes, see *Operator's Manual for Canon single console CXDI NE*.

### **CAUTION!**

---

**To avoid unnecessary radiation, make sure that the AEC back-up values are properly defined.**

---

# User Interfaces

## Overhead Tube Crane

---

### 3.2.5.1 Selection of Active AEC Field (AEC Mode Only)

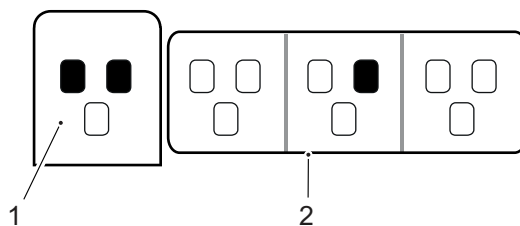

Fig. 3-15 AEC field selection

1. Activated AEC fields
2. Pop-up window for selecting AEC fields

The *AEC field selection* button is available in *AEC mode*

When selecting the *AEC field* button, a pop-up-window with the different AEC fields appears, see **Fig. 3-15**. The AEC fields are activated by selecting them in the pop-up window (2) to the right. All activated AEC fields are shown at (1). AEC fields are deactivated by selecting them again in the pop-up window (2).

### 3.2.6 Patient Size

The *Patient size setting* is used for a quick setting of the generator parameters to suit the physique of the patient.

Adjust *Patient size* by pressing the *Patient size selection* button. A pop-up window, according to **Fig. 3-16**, opens and shows available patient sizes.

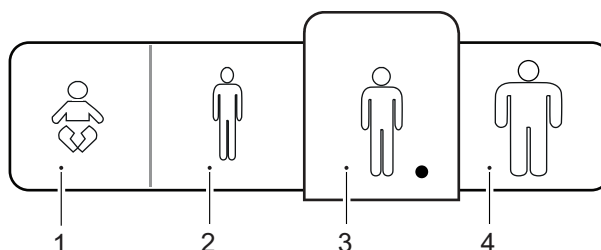

Fig. 3-16 Patient size selection

- |               |           |
|---------------|-----------|
| 1. Paediatric | 3. Medium |
| 2. Small      | 4. Large  |

Select the desired *Patient size*. The pop-up window automatically closes shortly after the selection.

Generator parameters and collimator settings (field size and filter) changes to the defined values for the new patient size. If no values are defined the current values is kept.

### 3.2.7 Collimator Centering

Adjust the collimator centering by pressing the *Collimator centering* button.

A pop-up window according to **Fig. 3-17** appears with the alternatives *Top centering* and *Bottom centering*. Select the desired collimator centering.

The pop-up window closes automatically short after the selection and the light field is accordingly adjusted.

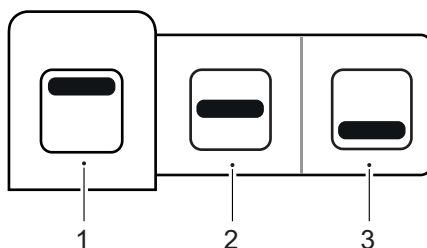

Fig. 3-17 Collimator centering selection

1. Top
2. Centre
3. Bottom

# User Interfaces

## Overhead Tube Crane

### 3.2.8 Hospital Method Book

The hospital method book is reached by activating the *Hospital method book* button for 1 second.

The hospital method book can be implemented in the system as a pdf-file. Please contact Service Engineer for support.

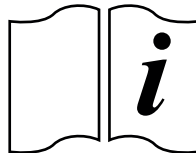

Fig. 3-18 Hospital method book

### 3.2.9 Automatic Collimator (option)

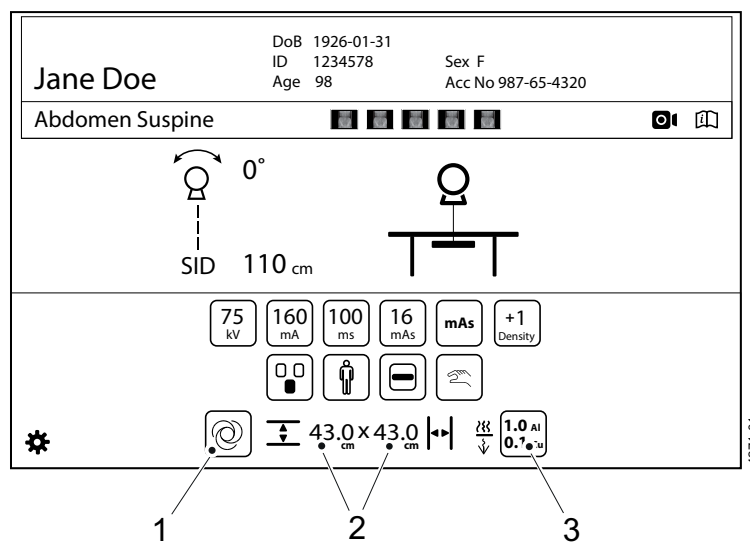

Fig. 3-19 Automatic collimator

1. Select Automatic or Manual mode of the collimator.

**Note!** \_\_\_\_\_

*If there is no new examination and the System is in Manual mode, the collimator ignores the instructions of sent collimator area from the Imaging system. This can be useful if the collimator area is intended to be kept for the next examination.*

2. Collimator light/x-ray field height x width
3. Collimator filter selection

### 3.2.9.1 Collimator Mode

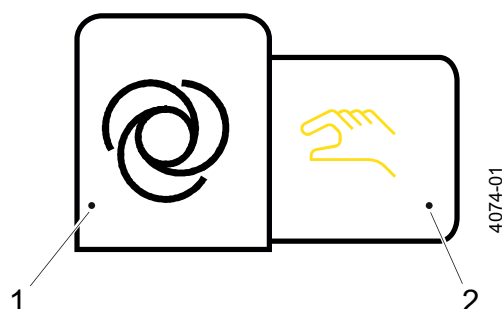

In automatic mode, the collimator light height and width is set from the anatomical program. The collimator light size can still be changed manually. In manual mode the collimator light height and width is not set from the anatomical program.

1. Automatic mode
2. Manual mode

Fig. 3-20 Collimator mode

When Automatic mode is selected, the predefined values of the collimator light / x-ray field size and the filter selection are set automatically when the anatomical protocol is selected. Both the light / x-ray field size and the filter can be changed when needed. In automatic mode the maximum light / x-ray field size is restricted to the maximum active area of the imaging unit.

When manual mode is selected the size of the collimator light / x-ray field size can be adjusted outside of the maximum active area of the imaging unit. When a new anatomical protocol is selected (for the same patient) the collimator light / x-ray field size or the filtration is not changed even if size and filtration is defined different in the protocol.

When changing from Manual mode to Automatic mode the collimator light / x-ray field size and filtration is restored to the values that were selected when changing from automatic to manual mode. Example:

- Automatic mode: Size: 30 cm x 10 cm; filter 1.
- Changes to Manual mode. Changes: Size: 30 cm x 20 cm, filter 2.
- Changes back to Automatic mode: Size 30 cm x 10 cm, filter 1.

When a new patient is selected Automatic mode is automatically activated.

### 3.2.9.2 Collimator Filtration Selection

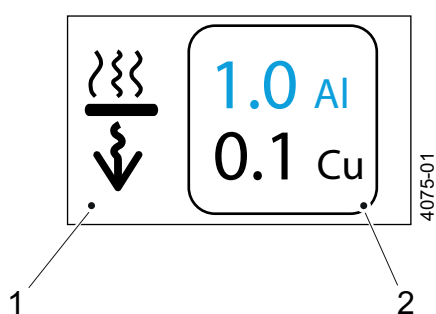

The user can change the selected value from the display.

1. Collimator filtration selection icon
2. Collimator filtration selection values

Fig. 3-21 Collimator filtration selection

See 3.6 for collimator filter options. The filters can be predefined in the anatomical protocol and also be changed if needed.

### 3.2.9.3 Laser

The laser can be switched off by applying a mechanical cover over the laser. The cover is available underneath the collimator.

# User Interfaces

## Overhead Tube Crane

---

### 3.2.9.4 Collimator Functionality - System

When the overhead tube crane moves in a direction that changes the SID, the collimator starts to compensate the field size. The collimator light field size on the imaging unit is held constant with changing SID.

When the overhead tube crane is tracking against the Wallstand or when the table top is released, the collimator light automatically is turned on. This is make it easier to directly find the correct stand and patient position.

In *Free mode/Auto position* mode the position of the detector is unknown for the System. The indicated size of the light field is correct at the shown SID.



### 3.2.9.5 Collimator Control Handle, Table (option)

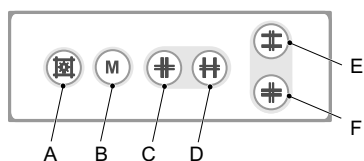

Fig. 3-22 Table collimator control handle

A. Button for switching the light and the laser line on/off. The light and laser line is automatically switched off via a time switch.

B. Button for changing between *Automatic mode* and *Manual mode*.

A long activation of the *M button* sets the light field to max image size, based on the pre-programmed SID value and the selected receptor.

C. Button for closing the format height collimation.

D. Button for opening the format height collimation.

E. Button for opening the format width collimation.

F. Button for closing the format width collimation.

# User Interfaces

## Overhead Tube Crane

---

### 3.2.10 Setting Menu

The setting menu is reached by a long activation of the *Setting menu* button.



- Press the *Setting* button for 1 second to reach the Settings menu.

Fig. 3-23 Setting button

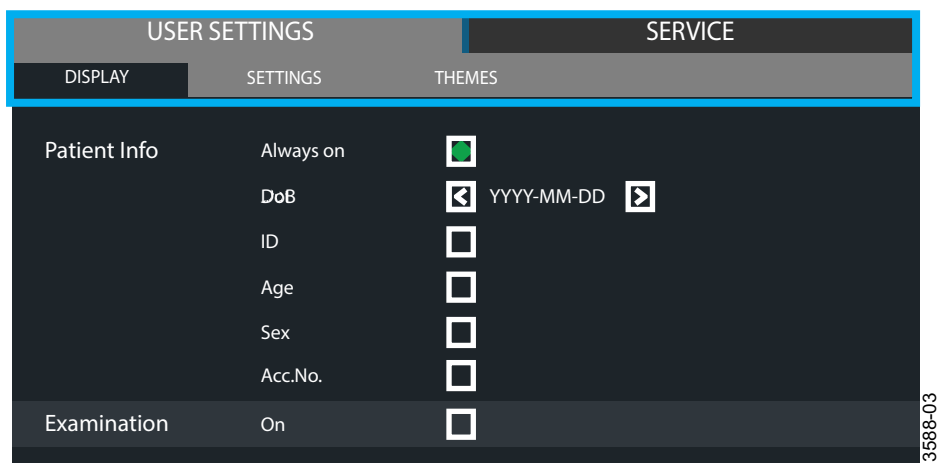

Fig. 3-24 Settings menu

The *Setting menu* has the following tabs;

- USER SETTINGS
- SERVICE

The USER SETTINGS menu has the following tabs:

- DISPLAY
- SETTINGS
- THEMES

The SERVICE menu has the following tabs:

- LOGS
- SETTINGS
- DISPLAY

### 3.2.10.1 User Settings – Display

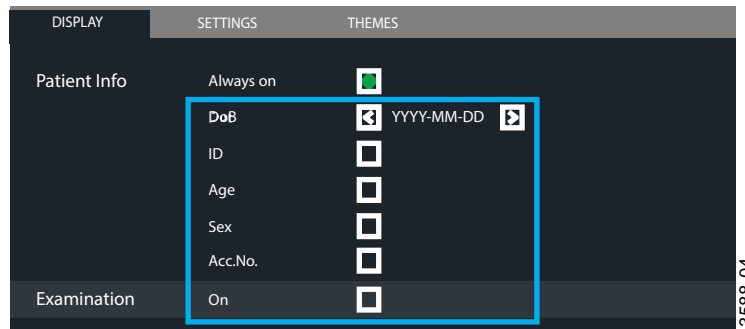

Fig. 3-25 Tab DISPLAY — Patient info

It is possible to select which patient information to show on the display. The following parameters can be selected:

- DoB; Date of Birth, where the following formats are selectable:
  - YYYY-MM-DD
  - DD-MM-YYYY
  - MM-DD-YYYY
- ID; the identity of the patient
- Age; the age of the patient
- Sex; the sex of the patient
- Acc.No; Accession number
- Examination – On; Examination/Active Protocol

#### Patient Info

#### CAUTION!

**The user shall always assure that the Patient info and the type of examination is corresponding to the one in HIS and RIS.**

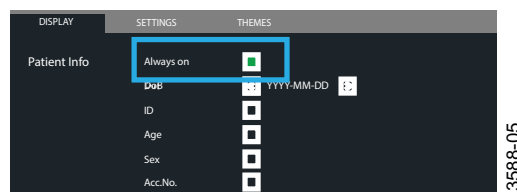

Fig. 3-26 Selection of Always on/off

The first line in USER SETTINGS menu, tab DISPLAY, refers to the selection if Patient information shall be shown (Always on) or not on the OTC display.

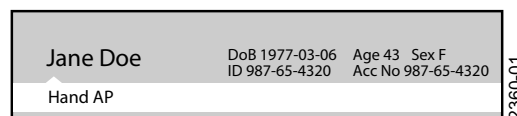

Fig. 3-27 Always on selected

When Always on is marked, patient information is shown as soon as the patient is selected.

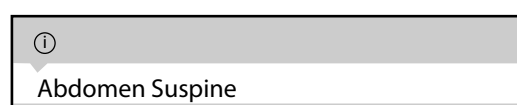

Fig. 3-28 Always on not selected.

When Always on is **not** marked, the Patient info is shown when pushing the black field with the ⓪

# User Interfaces

## Overhead Tube Crane

### Examination on

Not in use in this system

### 3.2.10.2 User Settings – Settings

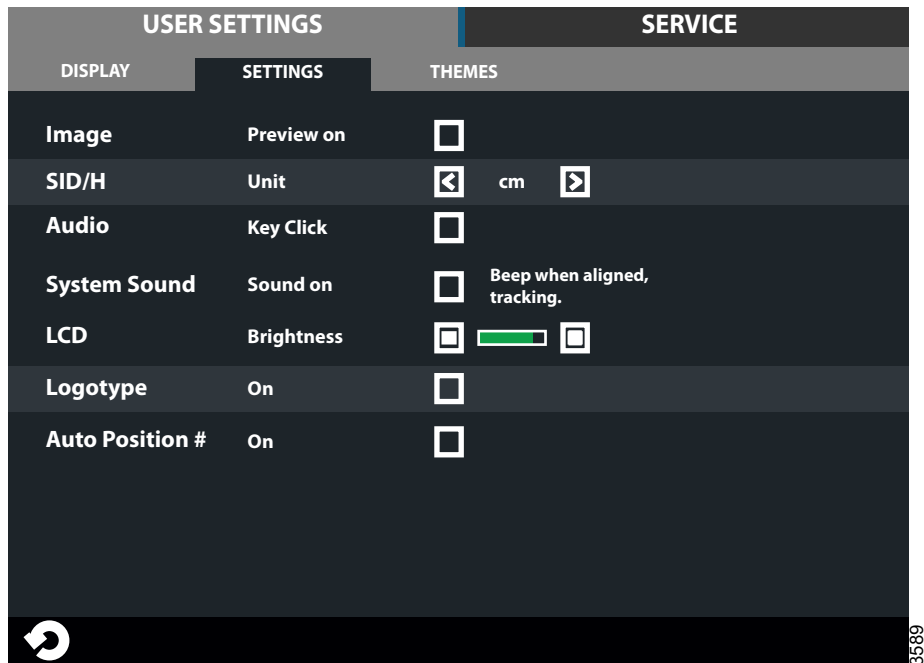

Fig. 3-29 Settings

In the **SETTINGS** tab it is possible to adjust the following:

- Image
- SID/H
- Audio key click, On/Off
- System Sound, On/Off
- LCD brightness, Plus/Minus
- Logotype in display, On/Off
- Autoposition, On/Off

– Image Preview on  
Image – Preview on

By selecting **Preview on** a small preview image is shown next to the Active Protocol name, see **Fig. 3-30**.

– SID/H Unit

**SID/H Unit** changes unit between cm and inch on both display and collimator.

– Audio – Key Click

By selecting **Key Click** a key click is heard when touching the System display.

– Sound – Sound on

By selecting **Sound – Sound on** a beep is heard when overhead tube crane is aligned with the detector, at tracking.

### Settings

#### Preview Image (not applicable for CR systems)



### **WARNING!**

**The preview image must not be used for diagnostics or positioning.**

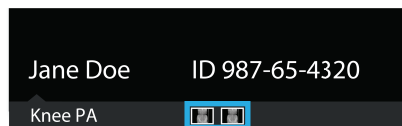

Fig. 3-30 Preview image displayed

If preview is selected, a small preview image, see Fig. 3-30, is shown on the touchscreen display when an exposure is performed.

Touch the small image on the display, and the image is shown as a large image.

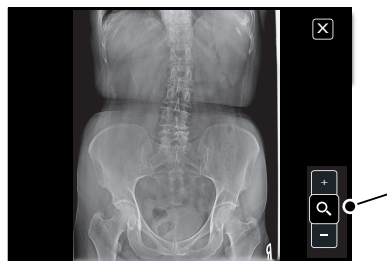

Fig. 3-31 Preview image enlarged

Touch the zoom button +/- to zoom in and out in the image.

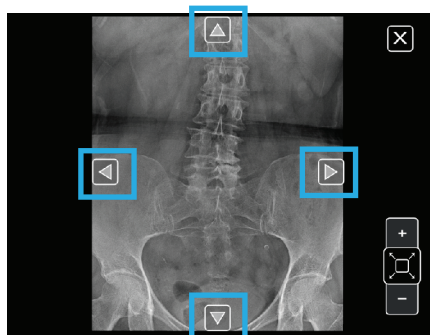

Fig. 3-32 Zooming In/Out

Use the arrows appearing in the image to pan in the image.

# User Interfaces

## Overhead Tube Crane

---

### Themes

Select a pre-set theme.

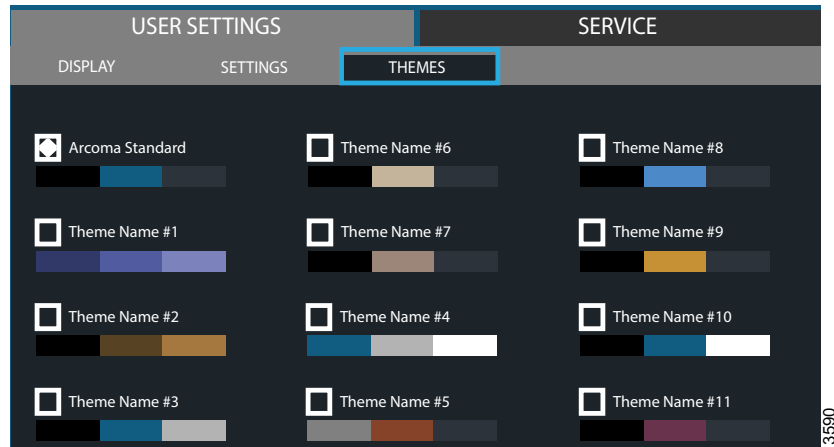

Fig. 3-33 Menu USER SETTINGS – tab Themes

Select a pre-set theme in tab Themes, see Fig. 3-33.

The selection changes the colours of the graphical user interface on the display of the overhead tube crane (OTC) according to the shown colour scheme.

### 3.2.10.3 Service

The Service tab is meant to be used by the service personnel.

#### Service – Log

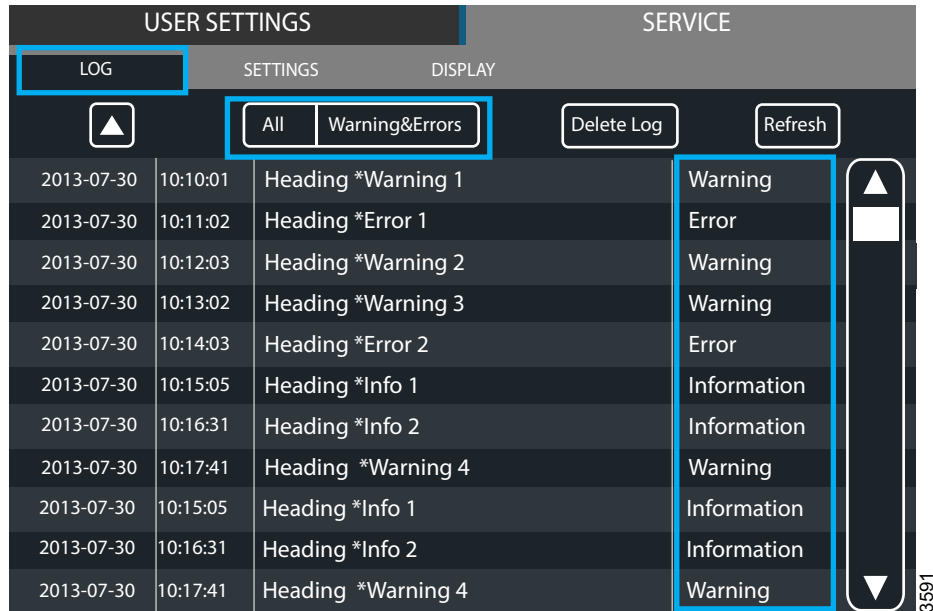

Fig. 3-34 Menu SERVICE – tab LOG

The log file shows warnings, errors and events that have occurred in the system. The log file can be filtered to show all information, All, or just warnings and errors, Warnings & Errors. By selecting Warning, Error, or Information in the right column, more information concerning the issue is shown.

The log file may be used for troubleshooting.

It is possible for service personnel to delete the log file which can be helpful when fault tracing. The refresh button retrieves the latest events.

#### Delete Log File

##### Note!

*This procedure shall only be performed by service personnel.*

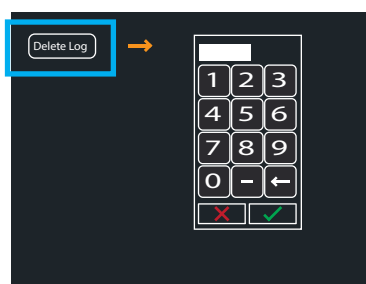

Fig. 3-35 Delete log file

Select Delete Log and enter a four digit access code to delete a log file.

# User Interfaces

## Overhead Tube Crane

### Service – Settings

The Service menu shows system set up and system software versions. A more detailed description can be found in the *Installation and service manual*.

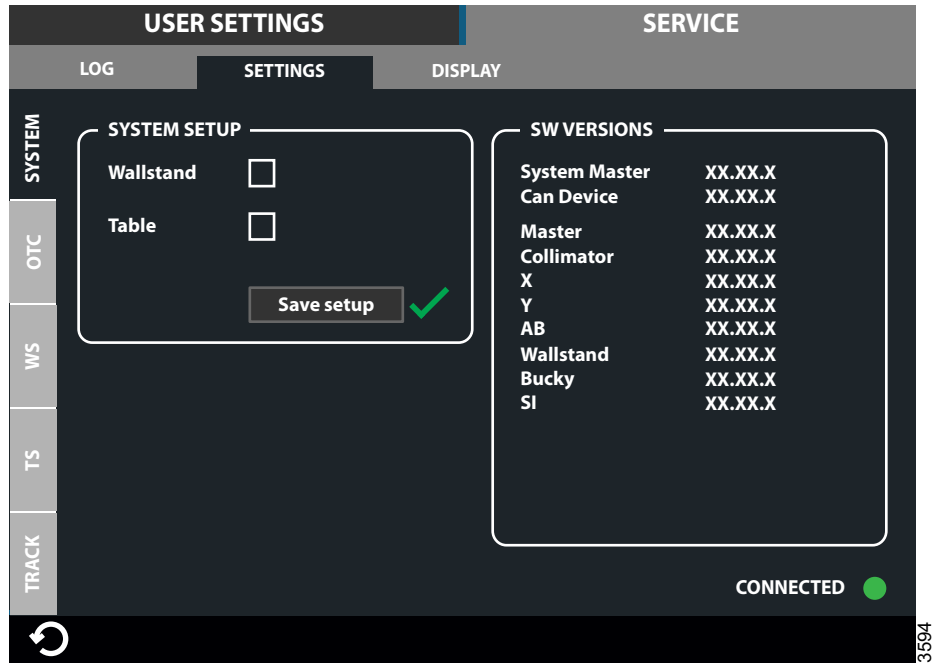

Fig. 3-36 Menu SERVICE – tab SETTINGS

### Service – Display

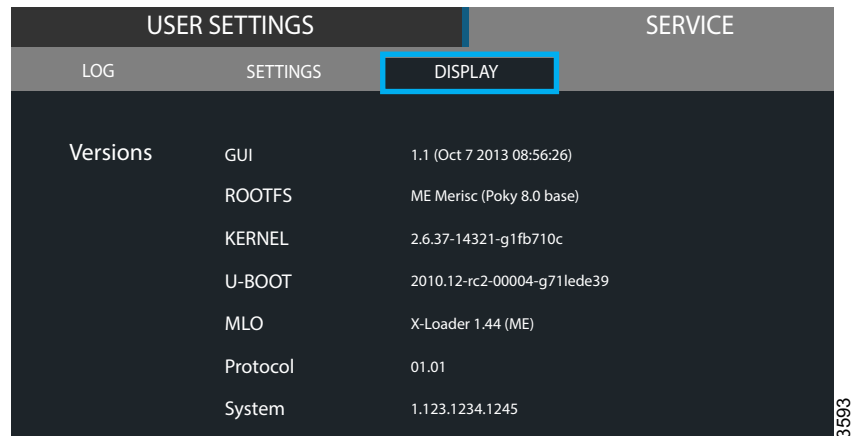

Fig. 3-37 Menu SERVICE – tab DISPLAY

Information of the display software versions.



### 3.2.11 Light Indication

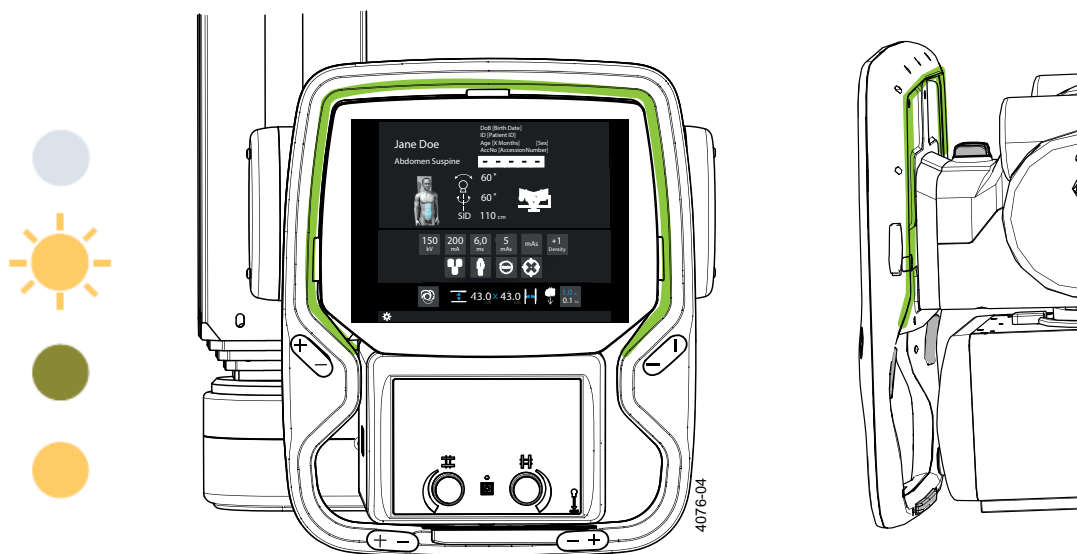

Fig. 3-38 Light indication

There is a light indication available around the overhead tube display.

- Blue light — Between examinations
- Yellow flashing — Tracking activated but tube not in position (synchronized)
- Green fixed — Preparation (before exposure), Tracking activated and in position, Free mode
- Yellow fixed — Exposure

### 3.3 Wallstand Control Elements

#### 3.3.1 Tiltable Imaging Unit Holder (option)

- A. Turn the lock handle (1) down to release the imaging unit holder (2).
- B. Tilt the imaging unit holder.
- C. Turn the lock handle up to secure the imaging unit holder in position.

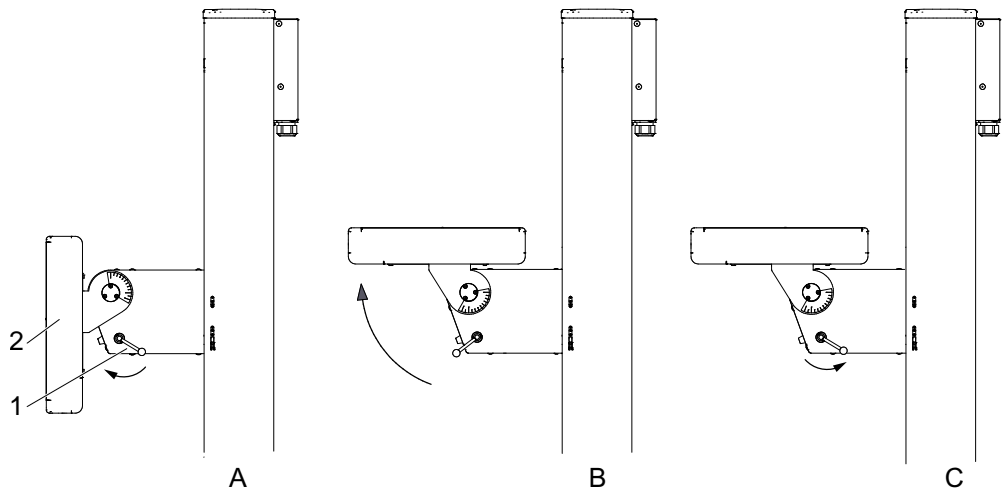

3781

Fig. 3-39 Tiltable imaging unit holder

The imaging unit holder can be set in any angle within a range of  $-20$  to  $90$  degrees.

The lock handle position can be adjusted.

Pull out and turn the lock handle to desired position. Right and left lock handles are adjusted individually.

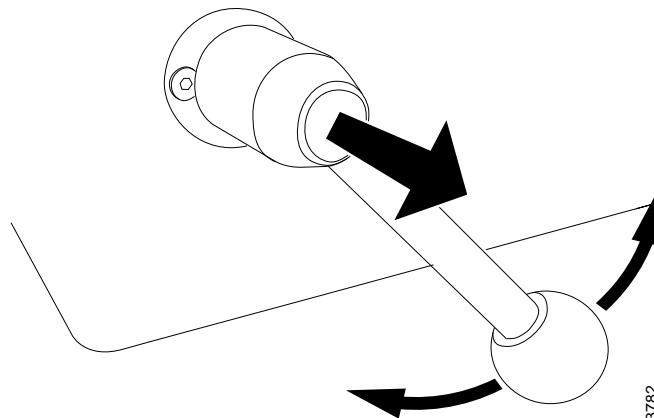

3782

Fig. 3-40 Lock handle

### 3.3.2 Wallstand Controls

The controls concerning the wallstand are positioned on the image unit holder bracket and on the floor next to the stand.

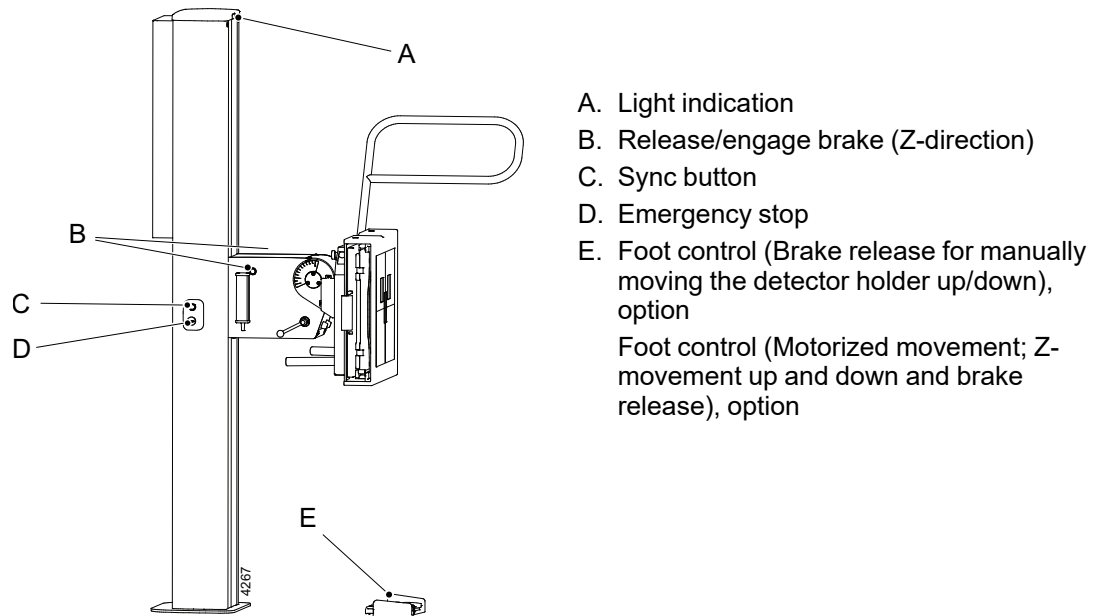

Fig. 3-41 Wallstand controls

#### 3.3.2.1 Light Indication

The selected workstation is indicated with a green light on the corresponding unit.

#### 3.3.2.2 Brake

Press the brake for manual movement in Z-direction. The synchronization button has the same function.

# User Interfaces

## Wallstand Control Elements

---

### 3.3.2.3 Foot Control For Vertical Movement, Wallstand (option)

The wallstand with motorized vertical movement is maneuvered from the foot control.

Consider the working area when the wallstand detector is maneuvered.

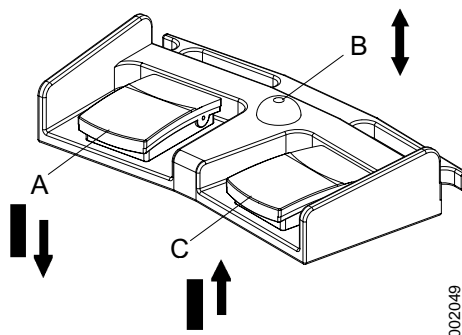

Fig. 3-42 Wallstand foot control

A Z movement down

B Brake release manual movement

C Z movement up

#### **How to Maneuver**

A. Press pedal to move the detector downward.

B. Press the brake for manual movement in Z-direction.

C. Press pedal to move the detector upward.

The speed up/down of the detector can be adjusted in the service menu.

### 3.4 OTC Control Elements

#### 3.4.1 Direction of Movement

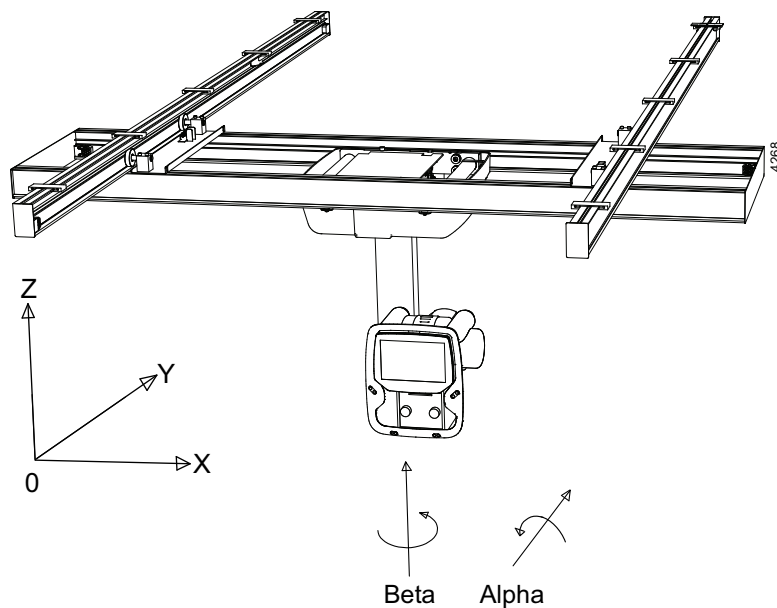

Fig. 3-43 Direction of movement

Z	Vertical movement	motorized
X	Lateral movement	manual
Y	Longitudinal movement	manual

# User Interfaces

## Manual Collimator

---

### 3.5 Manual Collimator

The basic functions of the manual collimator:

- Turn on/off the light.
- Change the size of the light field, adjust height and width.
- Change filter, rotate the filter clockwise or counterclockwise.

Four different filters can be chosen:

- 0 mm Al
- 2 mm Al
- 1 mm Al + 0.1 mm Cu
- 1 mm Al + 0.2 mm Cu
- FFD/SID measure tape.
- Laser (Option)

For further instructions on handling the collimator, see the *Collimator Manual*.

### 3.6 Automatic Collimator (option)

#### 3.6.1 General

The basic functions of the automatic collimator:

- Turn on/off the light.
- Change the size of the light field / X-ray field.
- Change pre-filtration.

Four different filters can be selected and are dependent on the collimator in the system.

(AL02):

- 0: 0 mm Cu
- 1: 0.1 mm Cu
- 2: 0.2 mm Cu
- 3: 0.3 mm Cu

Stiching collimator:

- 0: no filter
  - 1: 0.1 mm Cu + 1 mm Al
  - 2: 0.2 mm Cu + 1 mm Al
  - 3: 1 mm Al
- Measure FFD/SID with measure tape.
  - The automatic light is switched on when tracking of the wallstand or the table is active or when the table top is released. This will make positioning easier.

The automatic collimator also has additional features in order to support the operator and make the examination procedure easier.

- Optional collimator control handles available for remote control of light field, light on/off, collimator mode and centering.
- Function for fast adjustment of light field to the detector size.
- Function for top and bottom alignment available for examinations at the wallstand. See **3.6.3.5 Operating the Automatic Collimator, Wallstand, Page 90** for further information.

The size of the light field is calculated based on the programmed SID value. The pre-programmed SID-value is shown in the display of the automatic collimator.

See **3.6.3.3 Operating the Automatic Collimator, Table, Page 88** for instructions how to adjust the SID value.

#### 3.6.2 Basic Flow of Operation

Select an examination program from the image system.

When the collimator is in *Automatic mode* (shown as ACSS on the collimator):

- The collimator changes filter to the programmed filter for the chosen examination program.
- The collimator changes field size (width, height) to the programmed field size.
- The preferred SID is shown in the collimator display.

# User Interfaces

## Automatic Collimator (option)

### 3.6.3 Display and Control Elements

#### 3.6.3.1 Display Automatic Collimator

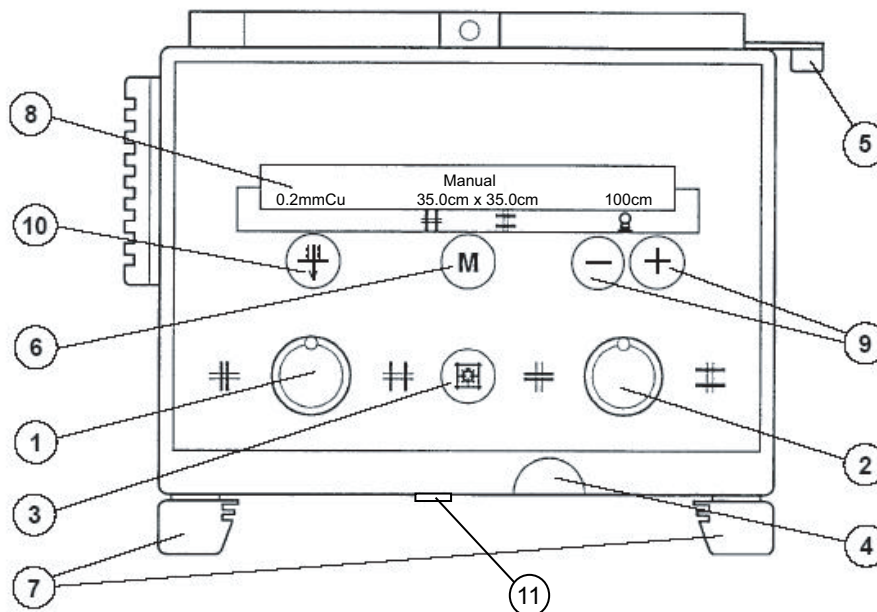

Fig. 3-44 Display and control elements

1. Format height collimation  
Turning to the left closes the collimator, turning to the right opens the collimator.
2. Format width collimation  
Turning to the left closes the collimator, turning to the right opens the collimator.
3. Light and laser line on/off  
The light and the laser line is automatically switched off via a time switch.
4. Measuring-tape (SID)  
The measuring tape has both a cm and an inch graduation.
5. Detent lever  
 $\pm 45^\circ$  rotation of the collimator around the central beam axis. The collimator stops in the  $0^\circ$  position.
6. Select automatic or manual mode  
A long activation of the M button will set the light field to the detector size if tracking WS or table is active. If no tracking is active, a long activation will set the light field to maximum size and automatic mode.
7. Accessory rails
8. Function display  
Shows manual or automatic mode (ACSS), pre-filtration, size of the light field and pre-programmed SID value.
9. SID (manually)  
The new SID value will be used for calculating the field size instead of the pre-programmed value, steps: 100, 115, 150, 180, 200.
10. Collimator pre-filtration
11. Control laser line cover



### 3.6.3.2 Collimator Control Handle, Table (option)

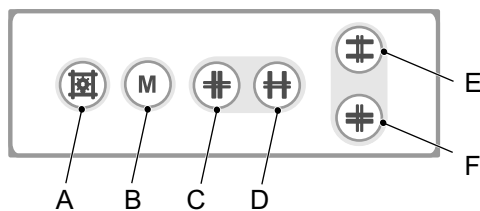

Fig. 3-45 Collimator control handle, table

- A. X-ray field illumination and linear light localizer on/off. Cutout is also performed automatically via a time switch.
- B. Automatic or manual mode.  
A long activation of the M button will set the light field to the detector size if tracking WS or table is active. If no tracking is active a long activation will set the light field to maximum size and automatic mode.
- C. Close format height collimation
- D. Open format height collimation
- E. Close format width collimation
- F. Open format width collimation

# User Interfaces

## Automatic Collimator (option)

---

### 3.6.3.3 Operating the Automatic Collimator, Table

#### **Startup Mode**

At startup of the system, the collimator is defined to *Automatic mode*, light field to *Maximum*, SID to *110 cm* and filter to the first defined.

#### **Find the Right Position**

The programmed SID value used for calculating the size of the light field is shown on the display of the automatic collimator. The correct position of the X-ray tube support is reached when the true SID value corresponds with the programmed SID value shown on the automatic collimator display.

The SID value is shown when the wallstand or table tracking is activated, the detector/detector holder is in a horizontal position and the tube alpha angle is between  $-45$  and  $+45$  degrees. When tracking is not activated and the detector holder is not horizontal, a measuring tape may be used to determine the SID.

When performing examinations at the wallstand with the detector holder in a vertical position the positioning indexes at the ceiling rails can be used in order to fast find the correct position.

#### **Automatic Collimator Light**

When the tube stand is tracking against the wallstand or when the table top is released, the collimator light will automatically be turned on.

#### **Change Working Mode**

The collimator can be operated in either *Automatic* or *Manual mode*.

*Manual mode* enables adjustment of the collimator light field outside the detector.

Select working mode on the collimator (button 6) or at the collimator control handle (button H).

#### **Automatic Mode**

The maximum light field size is restricted to the detector size.

#### **Detector Size**

When tracking table/WS is activated;

Adjust the collimator light field to the detector size by pushing and holding the *M-button* on the collimator control handle (button H) or on the collimator (button 6) for approximately 2 seconds.

#### **SID**

##### **Change SID**

The SID used for calculating the size of the light field can be changed manually with button 9 on the collimator.

The new SID value will be used for calculating the field size instead of the pre-programmed SID value.

#### **Note!**

---

*The system steps between pre-set values: 100, 115, 150, 180, 200.*

---

#### **Pre-programmed SID values**

If the SID values for each APR are pre-programmed at the Canon NE user interface, this will override the *collimator default value*.

### 3.6.3.4 Collimator Control Handle, Wallstand (option)

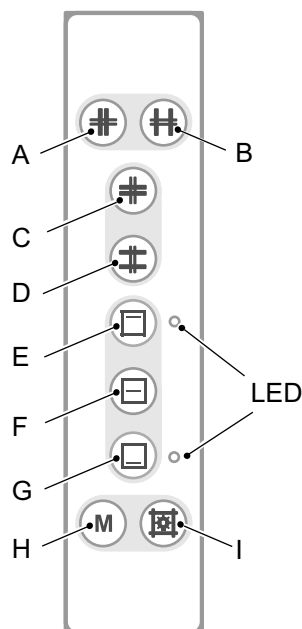

Fig. 3-46 Functions of collimator control handle, wallstand

- A. Close format width collimation
- B. Open format width collimation
- C. Close format height collimation
- D. Open format height collimation
- E. Top centering of collimator light field. LED indicating the selected position.
- F. Middle centering of collimator light field.
- G. Bottom centering of collimator light field. LED indicating the selected position
- H. Automatic or manual mode.

A long activation of the M button will set the light field to the detector size if tracking WS or table is active. If no tracking is active a long activation will set the light field to maximum size and automatic mode.

- I. On/off for light, laser line and automatic mode. The light and laser line is automatically switched off via a time switch.

# User Interfaces

## Automatic Collimator (option)

---

### 3.6.3.5 Operating the Automatic Collimator, Wallstand

For further information of how to operate the automatic collimator on the wallstand, see **3.6.3.3 Operating the Automatic Collimator, Table, Page 88**.

#### **Top and Bottom Centering**

The collimator light field can be top or bottom aligned instead of centered against the detector.

For top centering this means that the upper border of the collimator light field is aligned with the top of the detector.

For bottom centering the collimator light field is aligned with the bottom of the detector. The stand will automatically request synchronization to keep the alignment of the top or bottom of the detector when the collimator light field is increased or decreased. The functionality of top and bottom centering is available on a vertical detector on the wallstand.

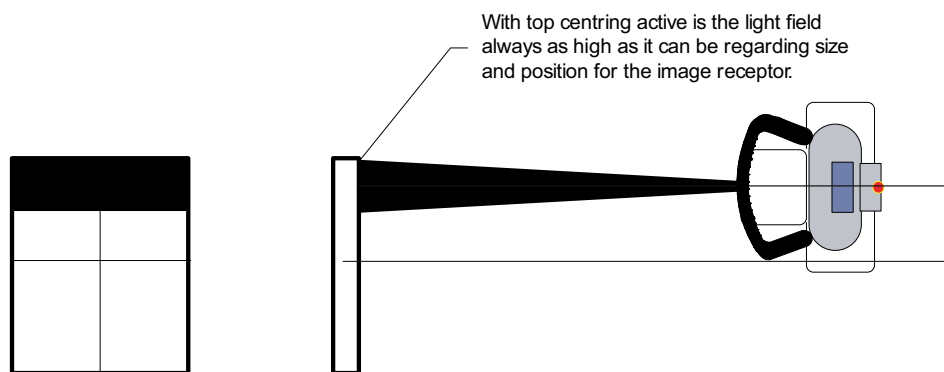

*Fig. 3-47 Top and bottom centering*

*With top centering active, the light field is always as high as it can be regarding size and position for the image receptor.*

### 3.7 DAP (option)

If a DAP meter is included in the system, the Dose Area Product will be presented in the image and included in the DICOM information.

Checks and settings can be done by the service software, see *Installation and service manual*, chapter 4 *Installation*.

# User Interfaces

## Table Control Elements

---

### 3.8 Table Control Elements

#### 3.8.1 Directions of Movement

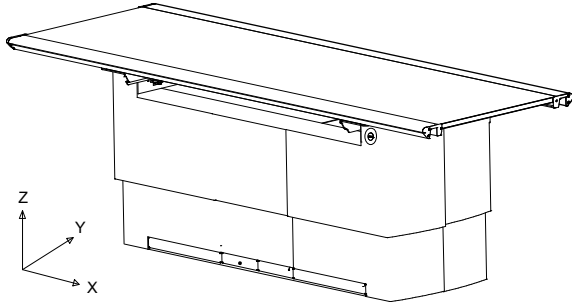

Fig. 3-48 Directions of movement, table seen from the front side

- Z Vertical movement
- Y Lateral movement
- X Longitudinal movement

#### 3.8.2 Directions of Movement

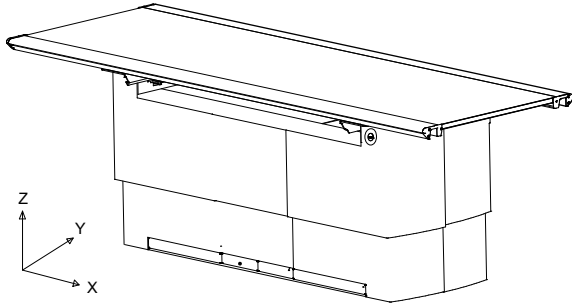

Fig. 3-49 Directions of movement, table seen from the front side

- Z Vertical movement
- Y Lateral movement
- X Longitudinal movement

### 3.8.3 Indication of Power to the Table

The device is powered when the green indicator light (A) on the table frame is lit.

*Note!* \_\_\_\_\_

*When no power, the usability of the table is highly limited.*

---

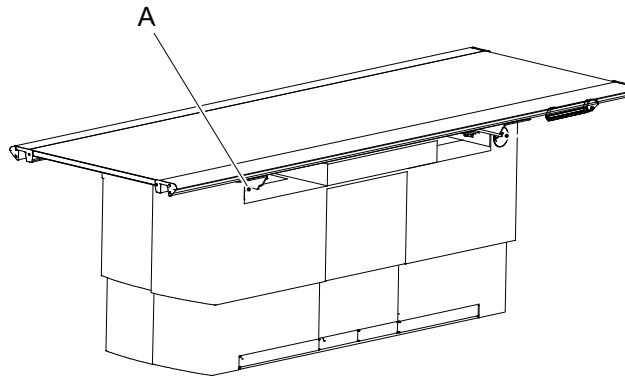

Fig. 3-50

# User Interfaces

## Table Control Elements

---

### 3.8.4 Foot Control, Table X/Y/Z (option)

The table with motorized vertical movement is maneuvered from the foot control. The foot control X/Y/Z is a standard control unit for table with motorized vertical movement.

Consider the working area when the table top is manoeuvred.

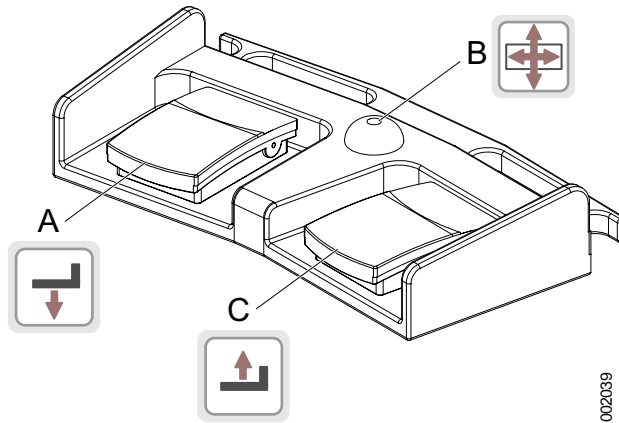

Fig. 3-51 Foot control

- A. Z movement down
- B. Unlock table top brakes (X/Y)
- C. Z movement up

#### 3.8.4.1 How To Manoeuvre

- A. Press pedal to move the table top downward.
- B. Press pedal to release the brakes on the table top, Y and X. When activated, the table top can be moved manually.
- C. Press pedal to move the table top upward.

### 3.8.5 XY Foot Control, Strip Type (option)

Press and hold the foot control strip type to release the brakes (X, Y) on the table top. When activated, the table top can be moved manually (floating table top).



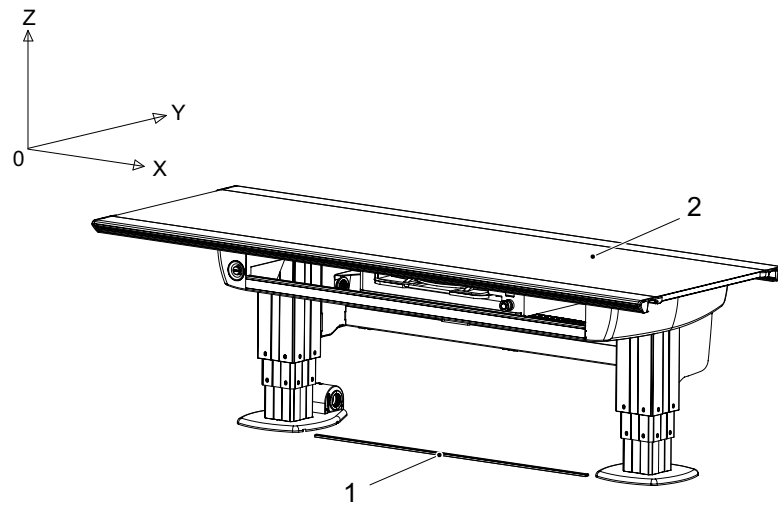

*Fig. 3-52 XY foot control, strip type*

1. *XY foot control strip type (option)*
2. *Table top (X/Y)*

### 3.8.6 Table Hand Control

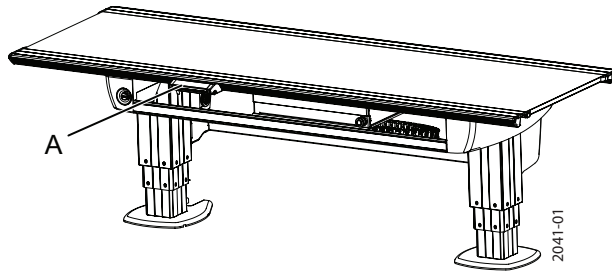

Fig. 3-53 Location of table hand control A

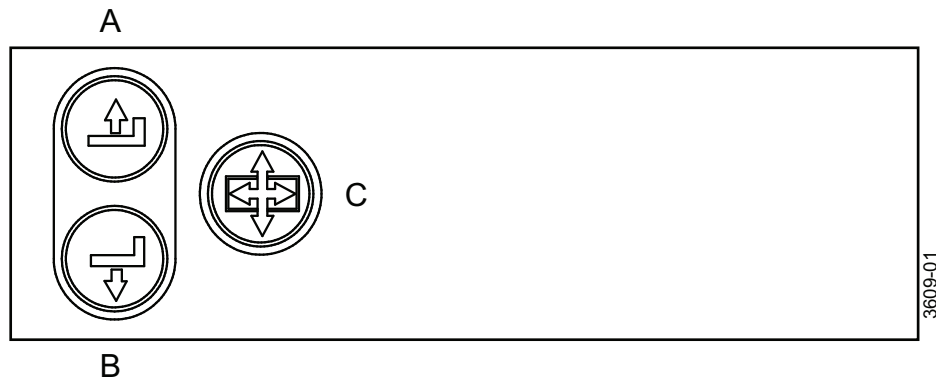

Fig. 3-54 Table hand control

#### 3.8.6.1 How to Manoeuvre

- A. Press button to move the table top upward.
- B. Press button to move the table top downward.
- C. Press the button to release the brakes on the table top, Y and X. When activated, the table top can be moved manually.

### 3.8.7 Moving Table Top

To manually move the table top, release the brakes and use the hand grip rails located at the long sides of the table top.

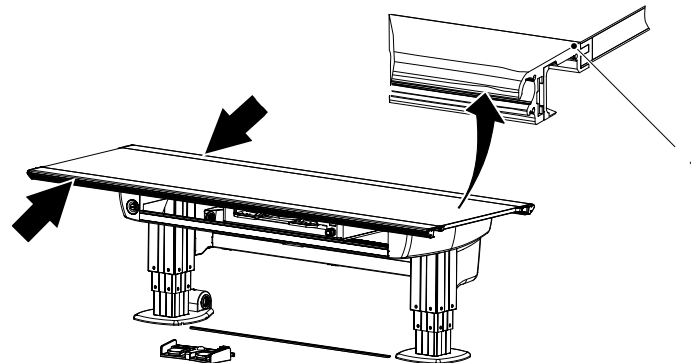

Fig. 3-55

1. Hand grip rail

### 3.9 Image System CXDI NE Software

Following information describes the CXDI NE software interface and is collected from *CXDI NE software Operation Manual*. For complete information, see *CXDI NE software Operation Manual*.

#### 3.9.1 General

The Canon CXDI software includes an X-ray generator settings panel, a generator parameter display window and an APR editor window.

The APR editor window is accessed via the protocol editor window access button. It is integrated into the Canon CXDI control software NE to implement the X-ray generator control and the X-ray image acquisition.

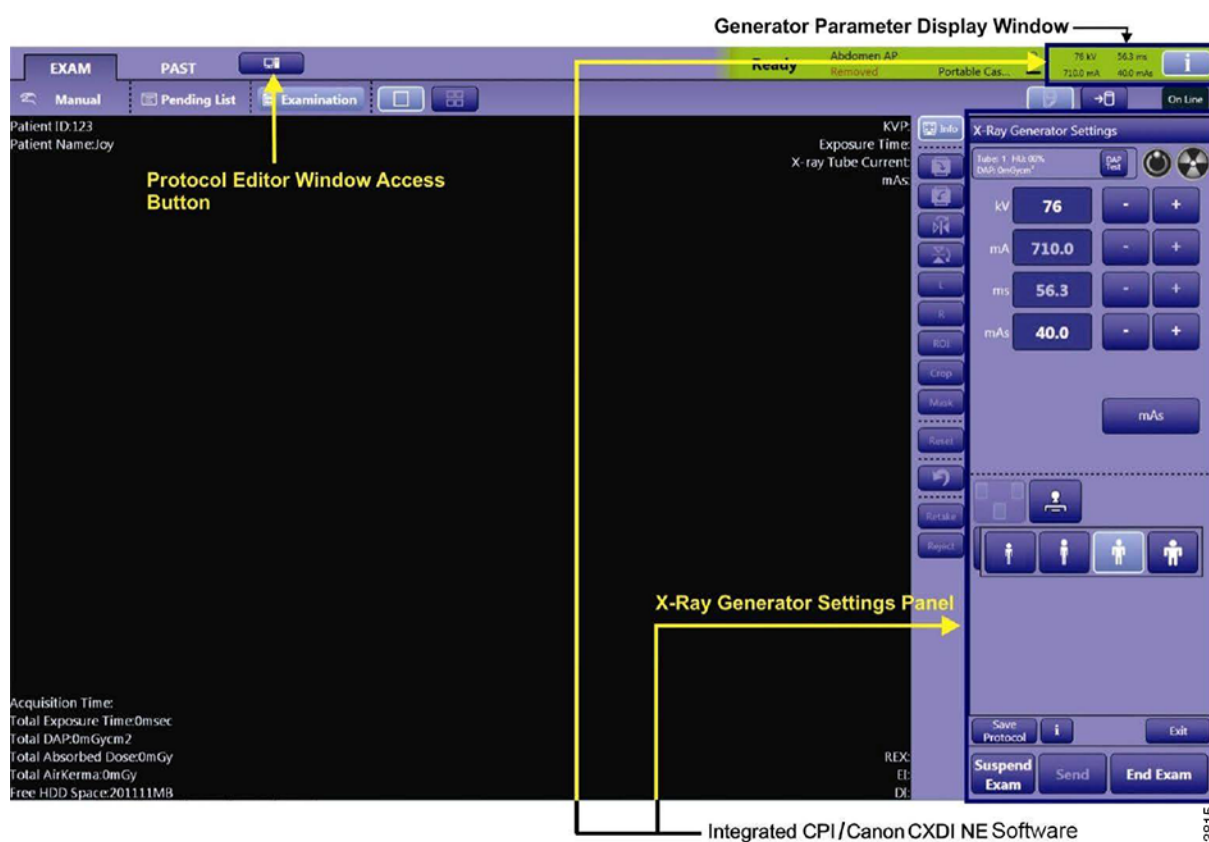

#### 3.9.2 Features

- Sets CMP 200@ DR X-ray generator control configurations
- Edits and saves the protocols that are stored In the Canon system.
- Displays the generator information
- Eliminates the need for a separate control console

### 3.9.3 Name Descriptions

Generator overwrap software	CPI / Canon CXDI NE software
Workstation	A mini-console and a computer installed with the Canon CXDI control software NE and the CPI / Canon CXDI NE software. Refer to the service manual supplement SLIP906566 for details.
Control panel	X-ray generator settings panel



Fig. 3-56

### 3.9.4 Generator Parameter Display Window

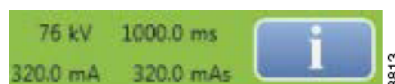

Fig. 3-57

The button  toggles between displaying and hiding the CPI control panel.

All four parameters kV, mA, ms and mAs are same as the values that are displayed in the control panel. These parameters will be updated based on changes in the control panel.

### 3.9.5 Control Panel

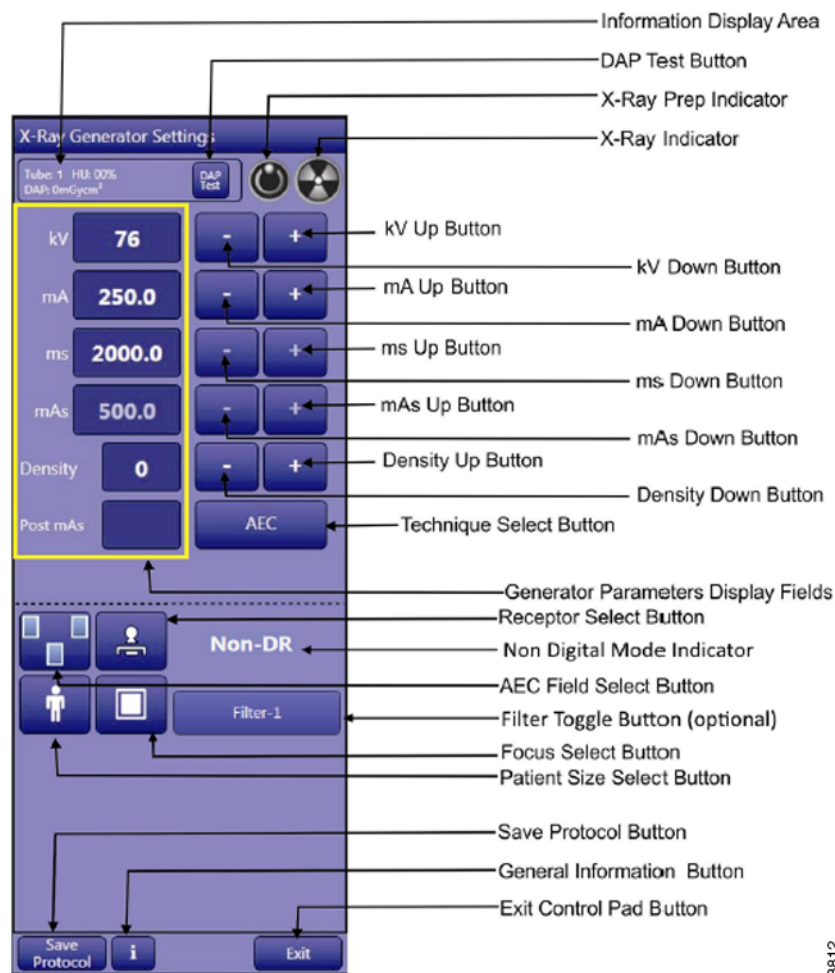

Fig. 3-58

3812

### 3.9.6 Radiography Controls

The control panel is used to temporarily change the default exposure parameters, AEC fields, receptors, body size, focus, and techniques for the selected protocol.

This panel is displayed on the main screen when the Canon CXDI Control Software NE is entered.

#### 3.9.6.1 Three Technique Modes

Example control panels are shown in the control panel mA / ms mode, the control panel mAs mode, and the control panel AEC mode below:

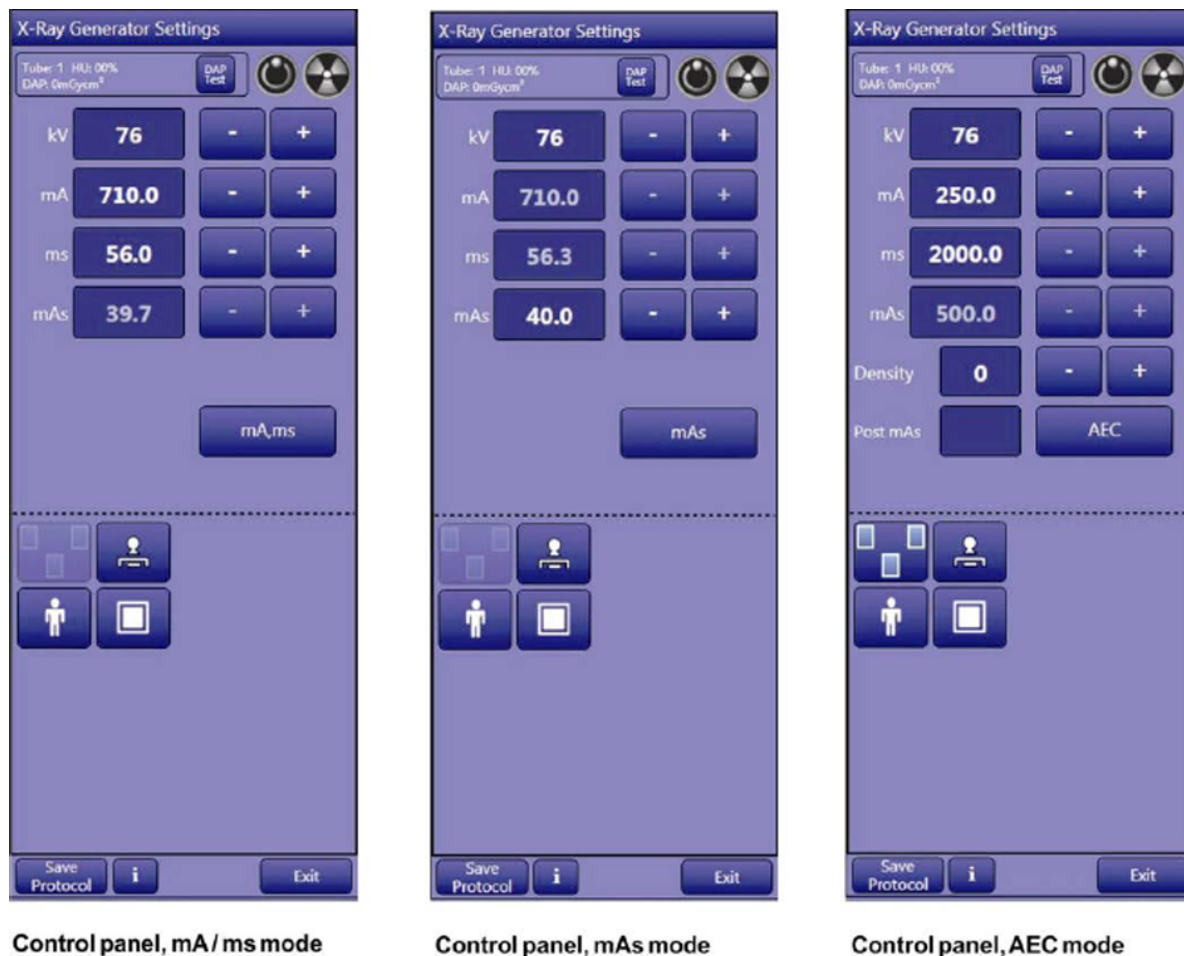

Fig. 3-59

3811

### 3.9.6.2 Display of Generator Parameters

Three parameters as shown below are displayed near the top of the control panel:

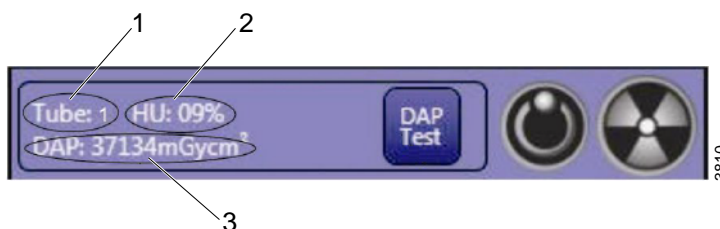

Fig. 3-60

#### 1. Tube indicator

This display will always indicate tube 1.

#### 2. Anode heat unit indicator (HU)

This display indicates the tube anode heat (percentage of the anode rating) for the selected X-ray tube. An anode heat-warning message will be displayed at an installer-programmable level, typically 80%.

Exposures that will exceed a value of typically 90% will be inhibited (this is also installer programmable).

#### 3. DAP display

This displays the accumulated dose-area product since the start of the exam. The DAP reading is shown in mGycm<sup>2</sup> or μGym<sup>2</sup>, depending on the units configured for display.

A display of "----- mGycm<sup>2</sup>" indicates that the DAP is disabled.

### 3.9.6.3 Status Indicators

	Prep indicator in the standby state.
	X-ray indicator in the standby state.
	Prep indicator in the prepare state.
	X-ray indicator in the X-ray state.
	X-ray is produced in this state.

### 3.9.6.4 Setting Exposure Parameters

Refer to the control panel window, see **3.9.6.1 Three Technique Modes**

#### ***KV Adjustment***

To increase kV, press **+ kV up** button.

To decrease kV, press **- kV down** button.

The demanded kV is shown in the left side of the kV down button on the control panel.

#### ***mA Adjustment***

To increase mA, press **+ mA up** button.

To decrease mA, press – **mA down** button.

The demanded mA is shown in the left side of the mA down button on the control panel.

### **ms Adjustment**

To increase ms, press + **ms up** button.

To decrease ms, press – **ms down** button.

The demanded ms is shown in the left side of the ms down button on the control panel.

### **mAs Adjustment**

To increase mAs, press + **mAs up** button.

To decrease mAs, press - **mAs down** button.

The demanded mAs is shown in the left side of the mAs down button on the control panel.

### **Density Adjustment**

To increase density, press + **Density up** button.

To decrease density, press – **Density down** button.

The demanded density is shown in the left side of the density down button on the control panel.

The user can also press and hold + / - button to increase / decrease the parameter continuously.

### **3.9.6.5 Setting Techniques**

Press the [Technique select] button to select the desired technique. Repeatedly pressing the button will cycle through the selections **mA/ms** → **mAs** → **AEC**.

 3804 for mA and ms mode (3 point technique, kV, mA and ms control).

 3803 for mAs mode (2 point technique, kV and mAs control).

 3802 for AEC mode (1 point technique, kV control only).

### **3.9.6.6 Setting Focus**

Press the [Focus Select] button to select the desired focal spot.

 for small focus.

 for large focus.

This function may be programmed for auto focal spot selection.

### **3.9.6.7 Setting AEC**

#### **AEC Field-Select Button (AEC mode only)**

The AEC field select button  is only enabled when the AEC technique is selected.

Perform field selection for 3-field AEC chambers:

1. Press the AEC field-select button.



- A pop-up window will be displayed showing all combinations of AEC fields.

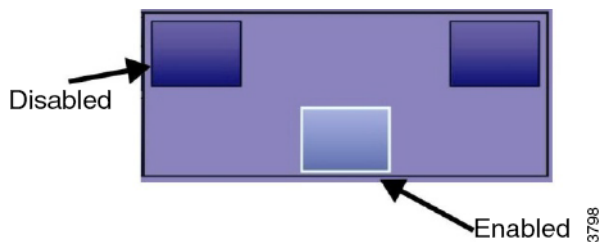

Fig. 3-61

The pop-up window will automatically close shortly if no selection is made after it opens.

**Note!**

*At least one AEC field must be enabled in the AEC pop up window.*

### 3.9.6.8 AEC Backup Display and Setting (AEC mode only)

The AEC backup mode is installer programmable (in Genware MP) for each receptor.

If "fixed" AEC backup has been programmed for the selected receptor, the backup ms is displayed as shown below, but this value cannot be adjusted.



Fig. 3-62

# User Interfaces

## Image System CXDI NE Software

---

If “ms” AEC backup has been programmed for the selected receptor, the backup ms is displayed as shown at the left and it is operator adjustable within preset limits.



Fig. 3-63

If “mAs” AEC backup has been programmed for the selected receptor, the backup mAs is displayed as shown at the left, and it is operator adjustable within preset limits.

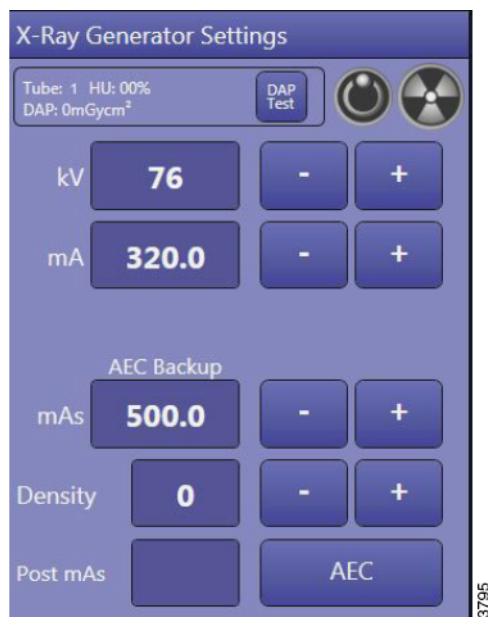

Fig. 3-64

If the operator is able to adjust the backup ms or mAs, the lowest practical values of ms or mAs should be used. These are values of backup ms or mAs that are low enough to quickly terminate an abnormally long AEC exposure but high enough that normal AEC exposures are not terminated by the backup timer.

### 3.9.6.9 DAP (Dose-Area Product)

The DAP function is only available if the optional DAP device is installed in the X-ray system, and if the DAP function has been enabled in programming.

#### **DAP Overview**

The DAP device must be allowed to stabilize when the generator is switched on. During this “settling” period, the DAP display will indicate “\_\_\_\_\_”. X-ray exposures may be made during this time, but the DAP function will be disabled during the settling period. The settling period may last up to a few minutes after the generator is switched on.

The DAP device is automatically tested by the generator after the settling period.

- If the DAP device passes the self-test, the DAP readout will display its last setting.  
This indicates that the DAP is functional, and ready to measure the dose-area product.
- If the DAP self-test fails, an error message will be presented.  
The DAP readout will display “\_\_\_\_\_”. This indicates that the DAP is not functional.

#### **Note!**

---

*A reading of 0 mGycm<sup>2</sup> indicates that the DAP display has been reset and that no exposures have been taken since it was reset. For example, this occurs when an exam is started.*

---

#### **Note!**

---

*Always check local regulations to determine how frequently the DAP device must be tested.*

---

#### **DAP Display**

- Before proceeding with initial dose-area product measurements, ensure that the DAP numeric value is 0 or blank.
- The DAP measures and displays cumulative dose-area product when in RAD mode. It may be programmed to measure and display the dose-area product for each tube individually, or to sum the readings from both tubes. This is installer programmable.
- The maximum accumulated reading on the DAP display is 9999999. An error message will be displayed when this limit is reached.

#### **DAP Test/Cancel**

A manual DAP functional test may be performed when desired, as described below.

The pop up window with [TEST] and [CANCEL] buttons will be displayed by clicking the



[DAP Test] button on the top of the control panel.

1. Press the [DAP TEST] button to test the DAP.

The window with the message DAP Test Passed will be displayed in the middle of the screen if the DAP has passed its test.

The window with the message DAP Test Failed will be displayed if the DAP has failed its test.

2. Press the [CANCEL] button to quit the DAP test.

### 3.9.7 Exam Tab

The four top tabs are Exam tab (1), Past tab (2), Online - offline(3) and System screen (4):

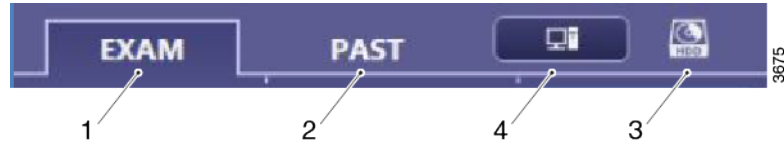

Fig. 3-65

#### 3.9.7.1 Worklist

Patients will be displayed which are retrieved from the worklist server.

##### Search for Study List

In search for study list it is possible to filter the worklist by name or ID. The results are displayed instantly while typing.

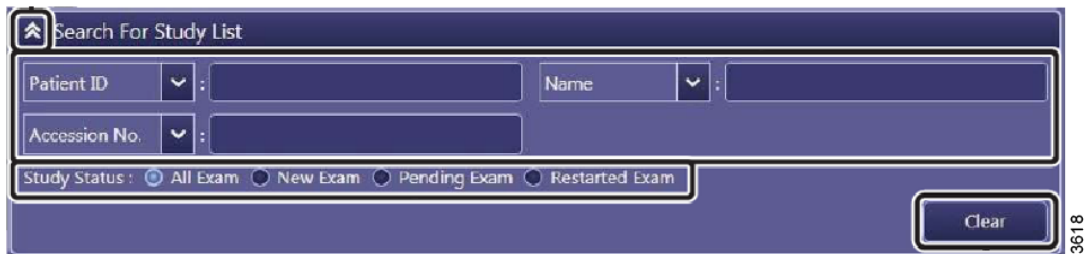

Fig. 3-66

- All Exam : Shows active and not finished examinations.
- New Exam Only : Shows only active examinations.
- Pending Exam Only : Shows only not finished examinations [Suspend Exam].
- Restarted Exam : Shows only restarted examinations.

##### Adapt Study List

Study List				
Name	Patient ID	Birth	Sex	Study Date
JOHN	1234567	10-6-1966	Male	7-6-2011
JOHN	1234567	10-6-1966	Male	7-6-2011

The number '3670' is visible on the right side of the table.

Fig. 3-67

The different columns are adjustable in order and in width.

# User Interfaces

## Image System CXDI NE Software

To change the orders of columns, click a column and keep the left mouse button pressed and drag the column to the desired place.

To change the column width: select the column separator when the mouse pointer changes, press the left mouse button to drag and change the width.

Study status can be restart or pending.

Patients who are suspended with the button [Suspended Exam] will have the study status pending in the workload.

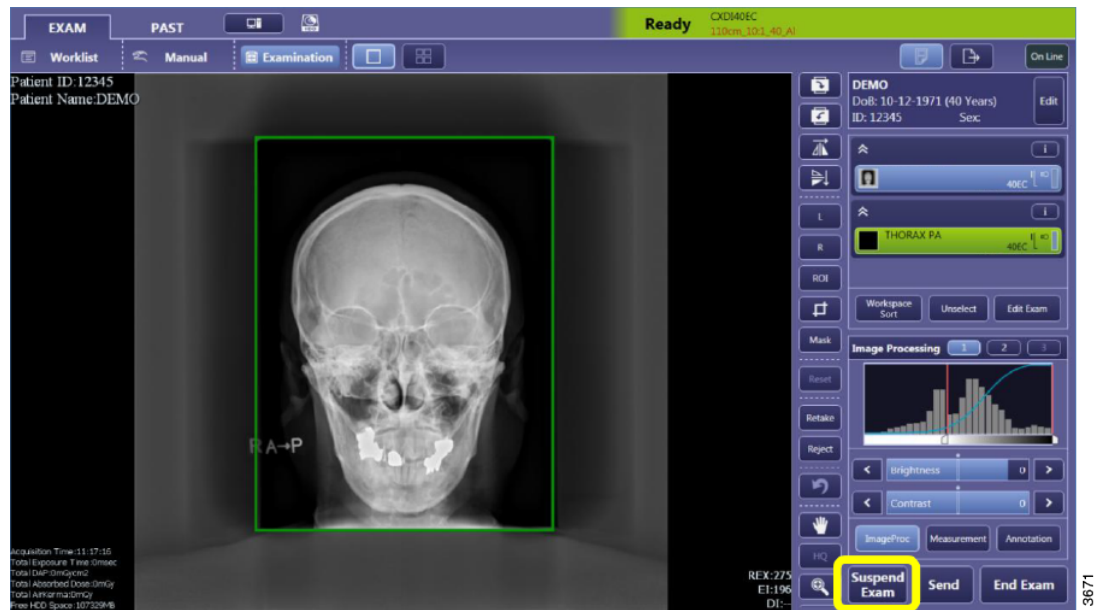

Fig. 3-68

# User Interfaces

## Image System CXDI NE Software

---

Pending patients will sustain in the worklist. To delete a pending patient one has to select the pending patient, start the exam and then select end or cancel, depending if images has been acquired in the exam.

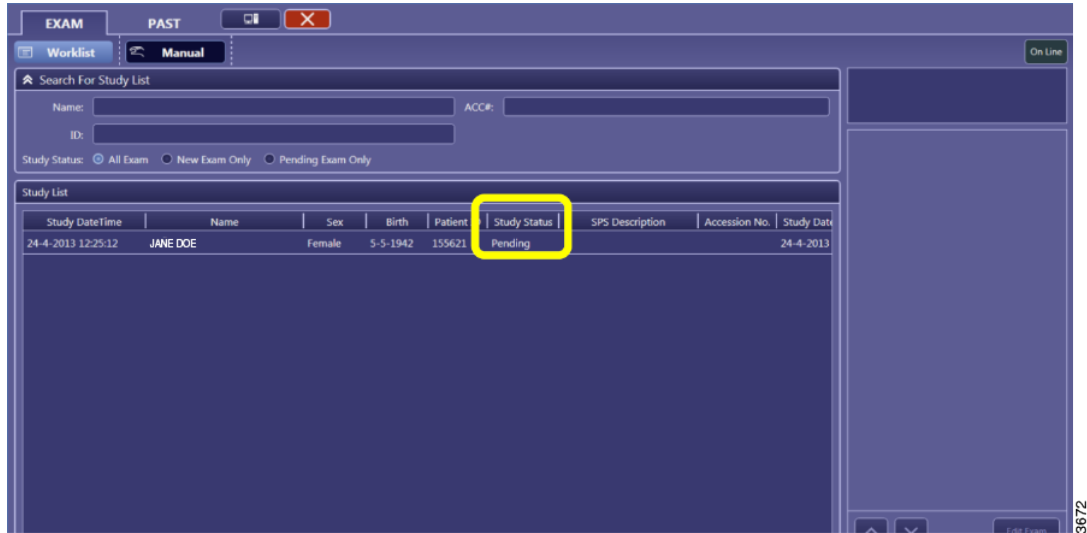

Fig. 3-69

### **Refresh Worklist, List Acquisition**

The worklist will be retrieved automatically when an acquisition is ended by [End Exam].  
When the worklist is displayed it will not refresh automatically.

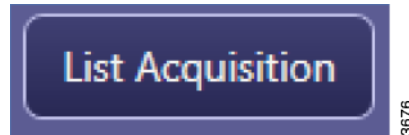
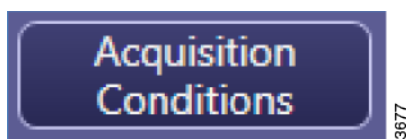

Fig. 3-70

[List Acquisition] will update the worklist with the latest data. This is only possible in online mode; if the offline mode is active this button will be grayed out.



Advanced search criteria can be entered in [Acquisition Conditions].

A screenshot of the "Acquisition Conditions" dialog box. The title bar reads "Acquisition Conditions". The form contains several input fields and options:

- ID : [text input]
- Name : [text input]
- ACC# : [text input]
- Requested Procedure ID : [text input]
- Range :
  - Period: [2] / [12] / [2012]
  - [4] / [12] / [2012]
  - Relative: [ ] hours from now
  - [ ] hours to now
  - All
- Modality :  DX  CR

At the bottom right, there are two buttons: "Cancel" and "List Acquisition". A small number "3678" is located to the right of the dialog box.

Fig. 3-71

[Acquisition Conditions] can be changed from day-period to time-period to retrieve patient data.

The settings are not persistent, after log out the default refresh as set in the Service Tool will be used.

# User Interfaces

## Image System CXDI NE Software

### Worklist Patient Selection

There are multiple workflow methods, the most useful will be described.

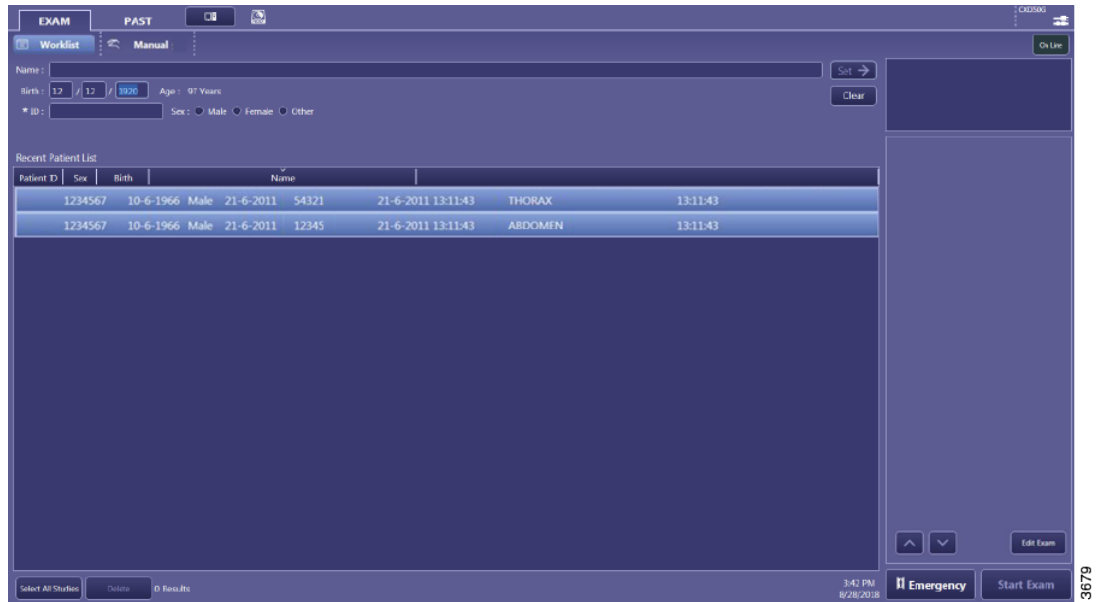

Fig. 3-72

Select the patient from the worklist. If the patient has multiple studies planned in the worklist the CXDI NE software will select them all.

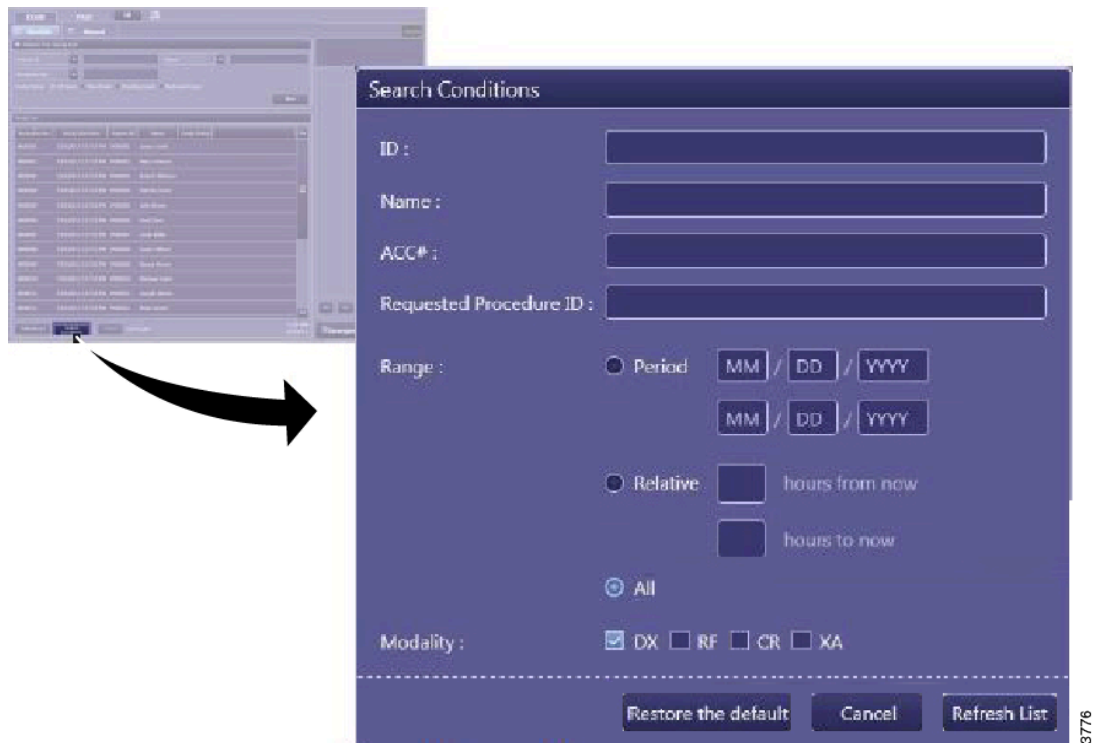

Fig. 3-73

Press [Search Conditions] and [Refresh List] if necessary.



If the system is programmed with prepacked protocols the studies will be filled automatically with protocols.

Add protocols to the studies with [Edit Exam].

Press [Start Exam] to begin the acquisition.

### 3.9.7.2 Manual

In the manual screen all patients, which has been selected from the worklist or entered manual in the past, are displayed. It is possible to select a patient from this list but keep in mind that only patient information will be used. Other information, like accession number will not be present.

#### *Manually Input Patient Data*

The screenshot shows the 'Manual' patient input screen. At the top, there are tabs for 'EXAM' and 'PAST'. Below these are 'Worklist' and 'Manual' buttons. The 'Manual' tab is active. The screen displays patient information for 'Jane Doe'. Fields include 'Name: Jane Doe', 'DoB: 11 / 11 / 1911', and '\* ID: 12345'. There are radio buttons for 'Sex: Male', 'Female', and 'Other'. A 'Set' button with a right arrow and a 'Clear' button are to the right. Below this is a 'Recent Patient List' table with columns for 'Patient ID', 'Sex', 'Birth', and 'Name'. The table is currently empty. At the bottom, there are navigation buttons: 'On Line', 'Add Study', 'Delete', 'Emergency', and 'Start Exam'. A 'Results' indicator shows '0 Results'. A vertical label '3660' is on the right side of the interface.

Fig. 3-74

Fill in the appropriate patient data.

Fields with an asterisk (\*) are mandatory.

Press [Start Exam] for next screen.

# User Interfaces

## Image System CXDI NE Software

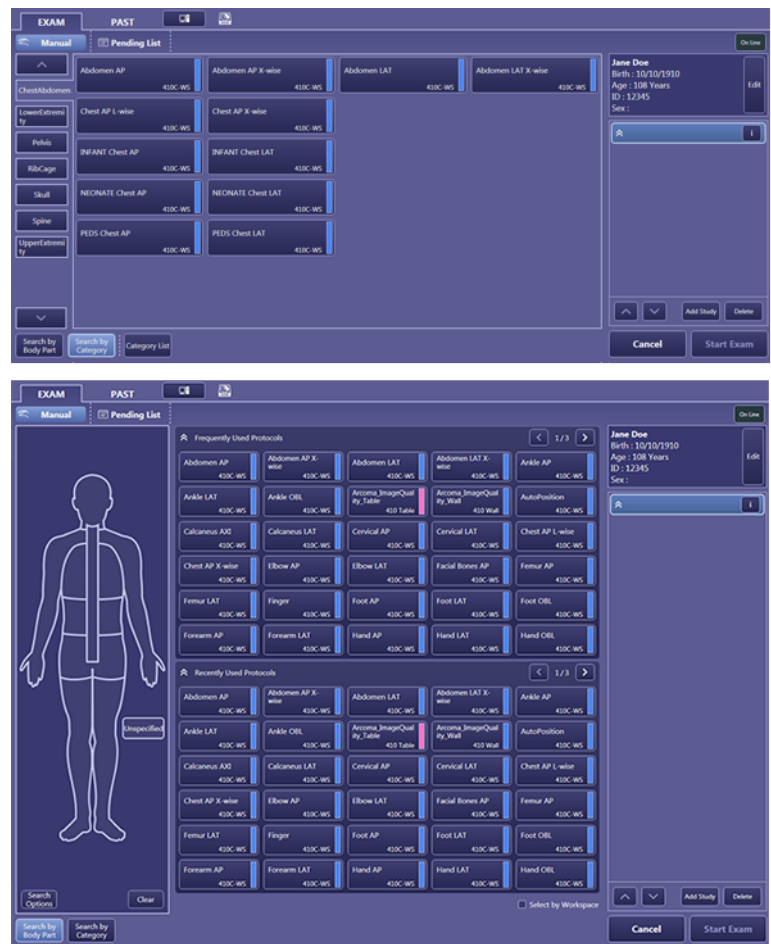

Fig. 3-75



There are two possibilities to search and add protocols:

1. Search by tray.
2. Search by bodypart.

### Search by Tray



Fig. 3-76

The protocols are presented in different tabs. Scroll through the tabs with buttons  / . A protocol can be added to the active study by click it once.

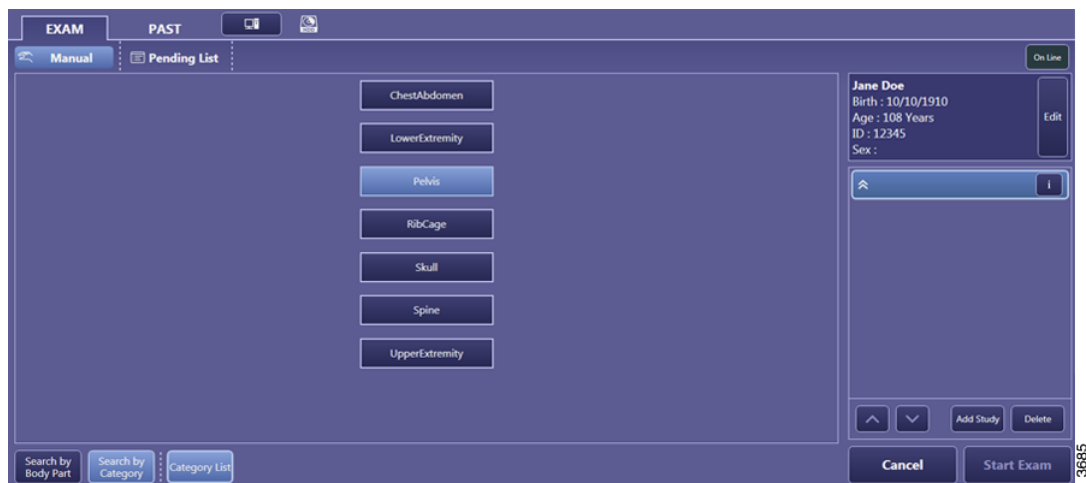

Fig. 3-77

This screen displays all available tabs. Access via the [Tray List] button. Press [Tray List] again to go to the previous screen.

# User Interfaces

## Image System CXDI NE Software

### Search by Bodypart



Fig. 3-78

Search bodypart to find a protocol quickly by using the anatomical diagram. Selecting an anatomical region will display all frequently and recently used protocols from that anatomical region.

With [Search Options], search by protocol name or view position.

With [Clear] all search criteria will be cleared.

When [Select by workspace] is not checked, the CXDI NE will show the protocols based on their frequently or recently used workspace.



Fig. 3-79

When the [Select by workspace] is checked, first the protocol is selected and then the workspace, see Fig. 3-80

# User Interfaces

## Image System CXDI NE Software

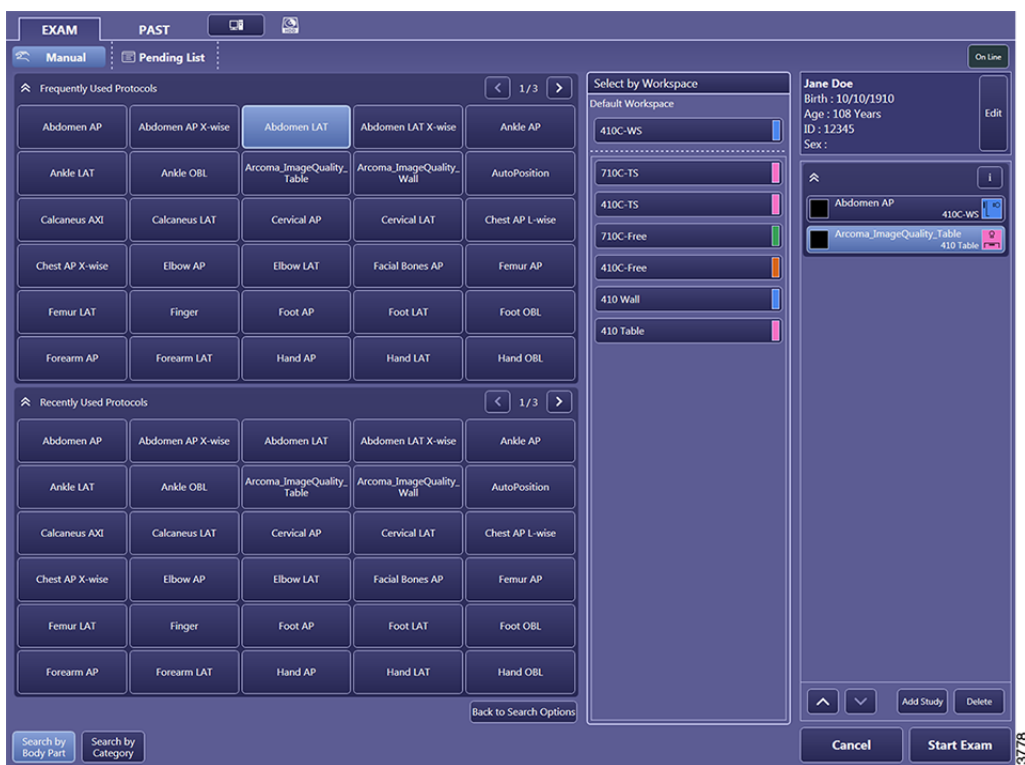

Fig. 3-80

Only workspaces available for the selected protocol is shown.

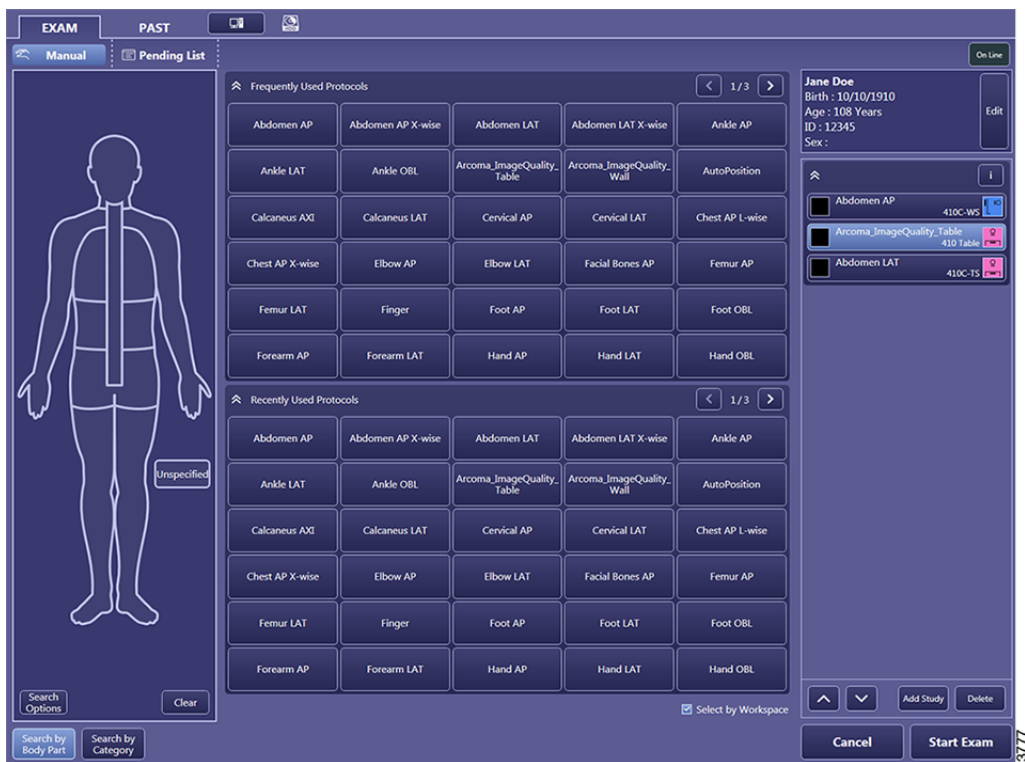

Fig. 3-81

# User Interfaces

## Image System CXDI NE Software

When the [Select by workspace] is not checked the preferred workspace is shown next to the protocol (colour and name) and both are selected at the same time.

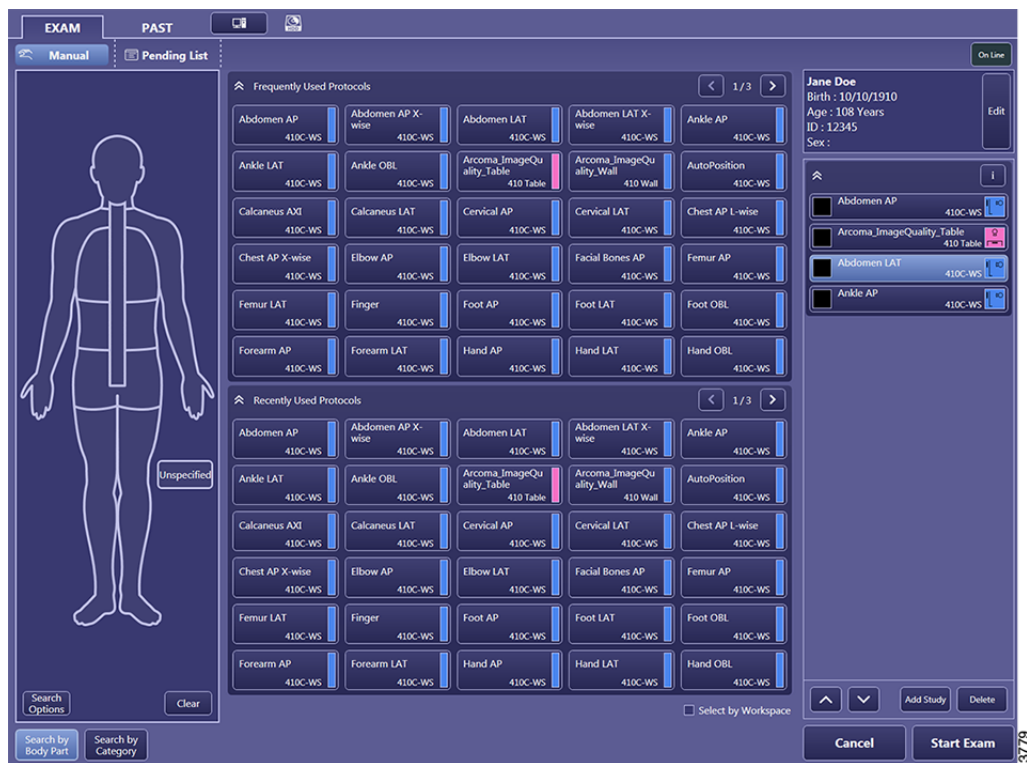

Fig. 3-82

If the user wants to change the selected workspace the predefined workspace is selected. All workspaces that are available for the specific protocol is shown.

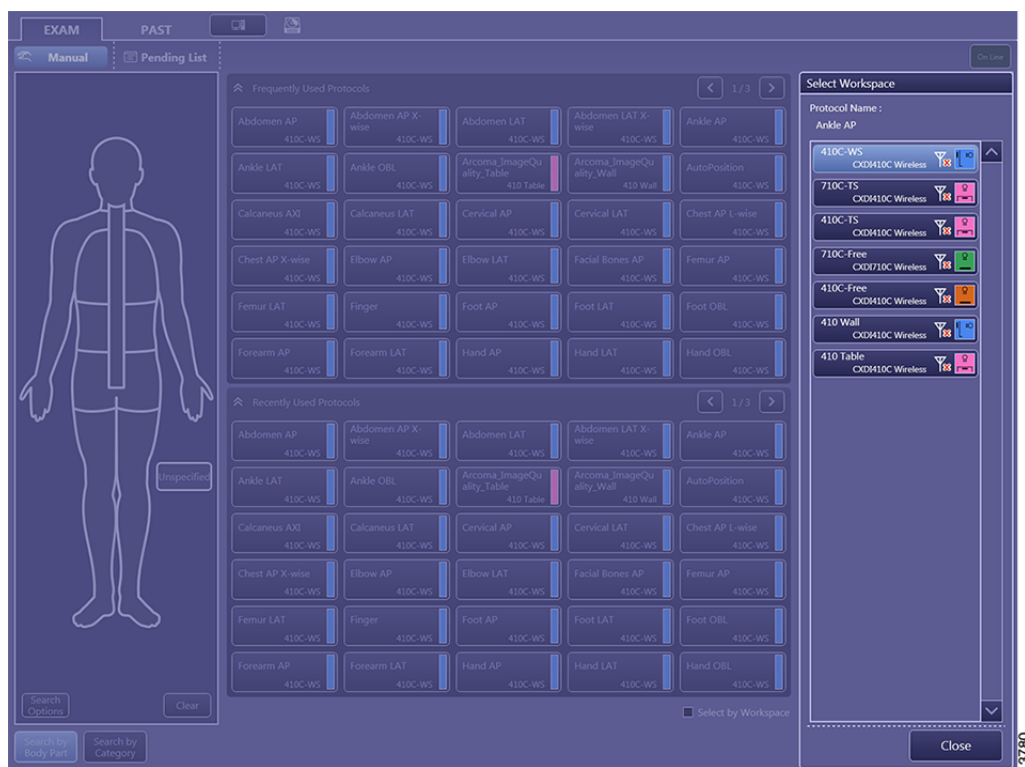

Fig. 3-83

### Image Processing Toolbar

The quality of an image is to a large extent determined by the digital image processing.

Keep in mind that the digital image processing is strongly dependent on sufficient exposure parameters.

The toolbar can be adjusted in the system properties. The order or presence of buttons within the toolbar may differ in this manual by the system.

# User Interfaces

## Image System CXDI NE Software

---

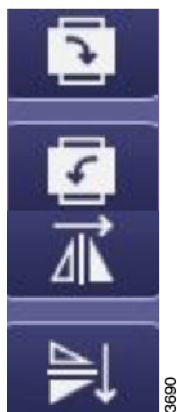

Rotate and mirroring.  
Rotation is set by 90 ° steps.  
Free rotation is not possible.



Left - Right marking letter. Depending on system settings, it will be shown at the bottom or top side.

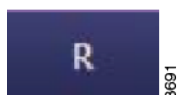

ROI (Region of Interest). The brightness (density) of the photo using the ROI can be modified.



The system will put a crop box around the X-ray field.  
The content of this crop box is sent to the specific destinations.  
With this button the crop box size can be changed.

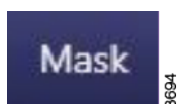

Normally, the area outside the X-ray field will be blackened, called black mask. With this button the black mask can be customized.



All actions will be undone.



Last action undone.



Overlay on - off.



The currently selected photo is rejected and the protocol is added to acquire the image again. The rejected image will not be sent to destination. With [Resume] alternately the first image or second image is being rejected. A rejected image can be send from the past list.



The currently selected photo is rejected. With reject the protocol is not added automatically. If a rejected image has to be send afterwards it is possible with [Resume] to change back the status of the image to normal.





Pan the image when zoomed in.



Zoom the image.

# User Interfaces

## Image System CXDI NE Software

---

### ROI

Press the button [ROI] (region of interest) to create a new box by clicking 2 opposite corners with the left mouse button. Create a new box by drawing a box while keeping the left mouse button pressed.

The system will see the new ROI area as the region of interest and the picture will adjust the brightness accordingly.

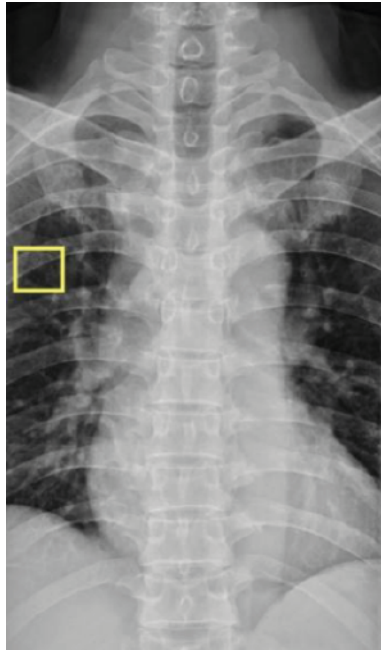

ROI in lung area

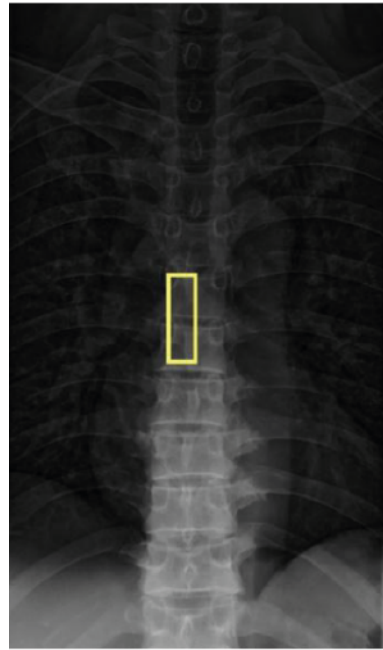

ROI in vertebra area



ROI- acknowledge

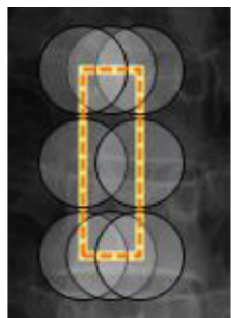

ROI - Select

When [Select] is pressed, the size of the ROI area can be changed by dragging one of the circles.

Confirm with [OK].

### Crop

The system will put a crop box around the X-ray field. The content of this crop box is sent to a specific destination.

If the radiated area on the detector has been rotated, so not in line with the detector borders, the crop box will be a square surrounding the complete radiated area.

Press  to create a new box by clicking two opposite corners with the left mouse button or draw a box while keeping the left mouse button pressed.



Automatic crop box

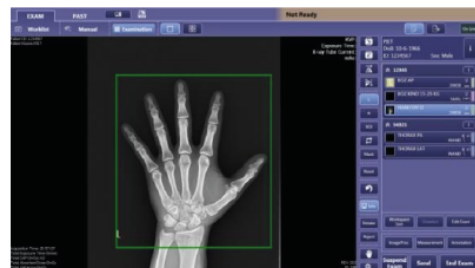

Crop box modified

Press [Select] and drag one of the circles.

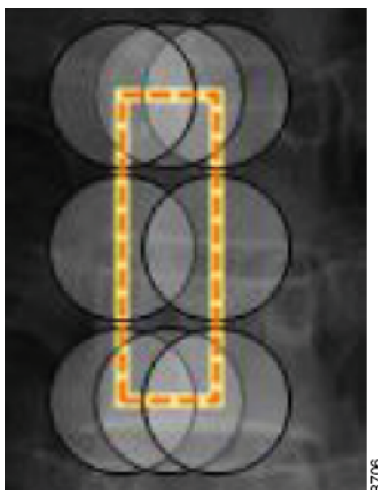
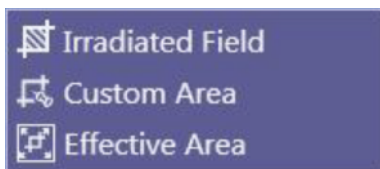

Fig. 3-84

The crop box can be shifted with the buttons .



- Irradiated Field = exposed area
- Custom Area = specific area set in service tool
- Effective Area = Entire detector area

Confirm with [OK].

# User Interfaces

## Image System CXDI NE Software

---

### Mask

Normally, the area outside the exposed area is given a black mask. Press the [Mask] button to customize the black mask area.

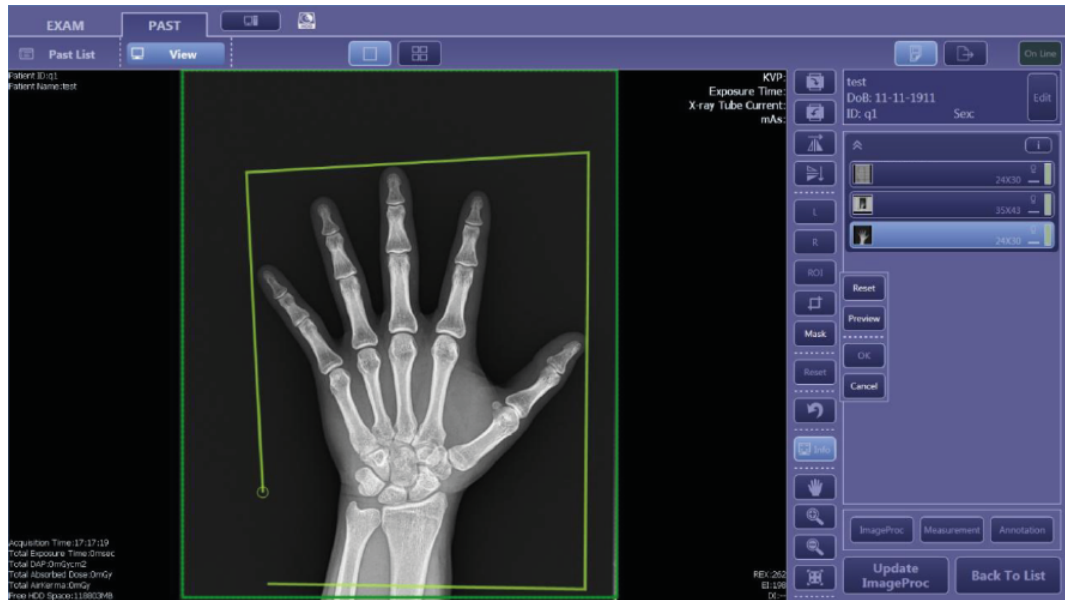

Fig. 3-85

Press the [Mask] button to draw a self defined field. Press the left mouse button to create an anchor point. There can be up to 12 anchor points.

The black mask on the system is shown semi transparent, on a PACS screen or on a hard copy it will be shown completely black.

Confirm with [OK].

### 3.9.7.3 Examination

Select [Start Exam] to reach Examination tab.

#### **Manually Add Studies and Enter Accession Numbers**

Manually adding studies is only possible when a patient has been set manually. When a patient has been selected from the worklist, or selected via the emergency button, it is not possible to add studies.



Fig. 3-86

Example of a manually entered patient. When the patient was selected from the worklist the [Edit] button would be an Info button.

With the [Add Study] button the protocols are subdivided into different studies. Each study can have an accession number and study description. Press the **i** button for that study. [Delete] deletes the selected protocol or a complete study.

Change the protocol order with **^** and Press **i** for more information on a specific study. These fields are collected from the worklist server. **v**.



Fig. 3-87

Press [Edit].

The information is collected from the worklist server and cannot be changed.

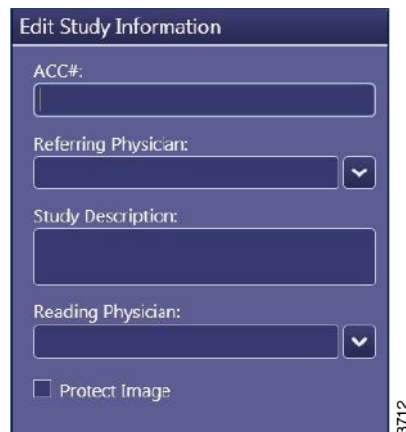

Fig. 3-88

### **Secure Images Against Erasure: Protect Image**

The CXDI NE software erases the images with the first in - first out principle. The oldest image will be erased when the data disk has reached its upper limit.

To prevent an important image for erasure it is possible to protect it. This is done during the acquisition as well from Past tab.

To protect a study press the  button.



Fig. 3-89

Select [Edit].

Check [Protect Image] to prevent this study from automatic erasure.

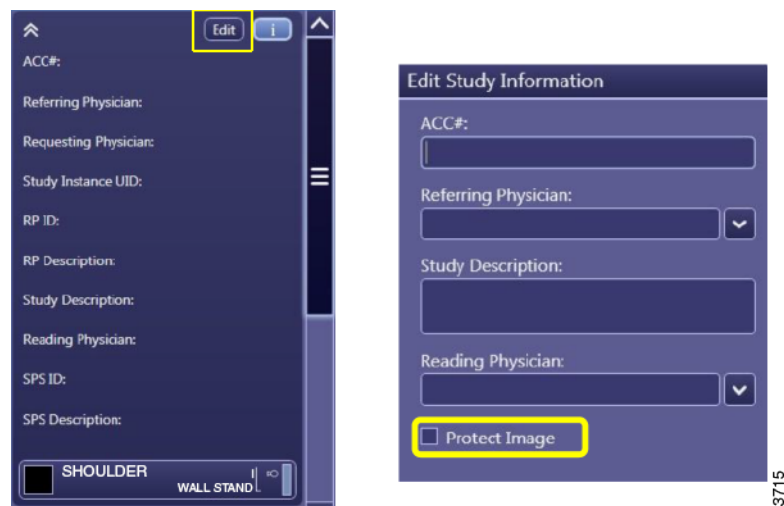

Fig. 3-90

### 3.9.8 Past Tab

Old images can be retrieved. Retrieved images can be changed and resent to a destination. The [Past List] can be called by selecting the past tab in the main screen.

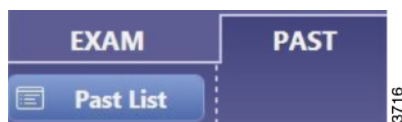

Fig. 3-91

Fill in the search criterias.

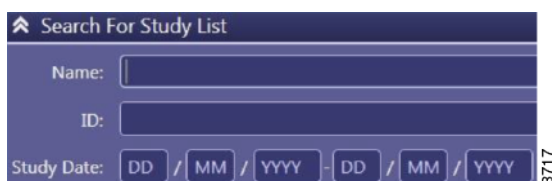

Fig. 3-92

When a patient is selected in the past list it will show all exams for this patient. The exams will be presented by name and a thumbnail preview of the image.

Press [Refer Exam] to go to the next screen.

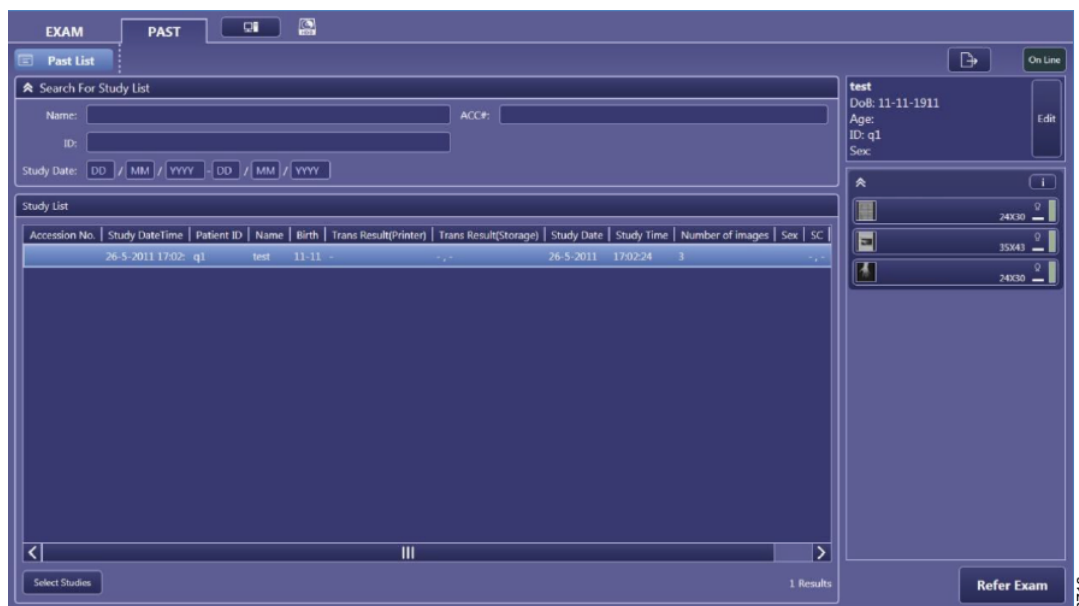

Fig. 3-93

Select a protocol for displaying and changing the image.



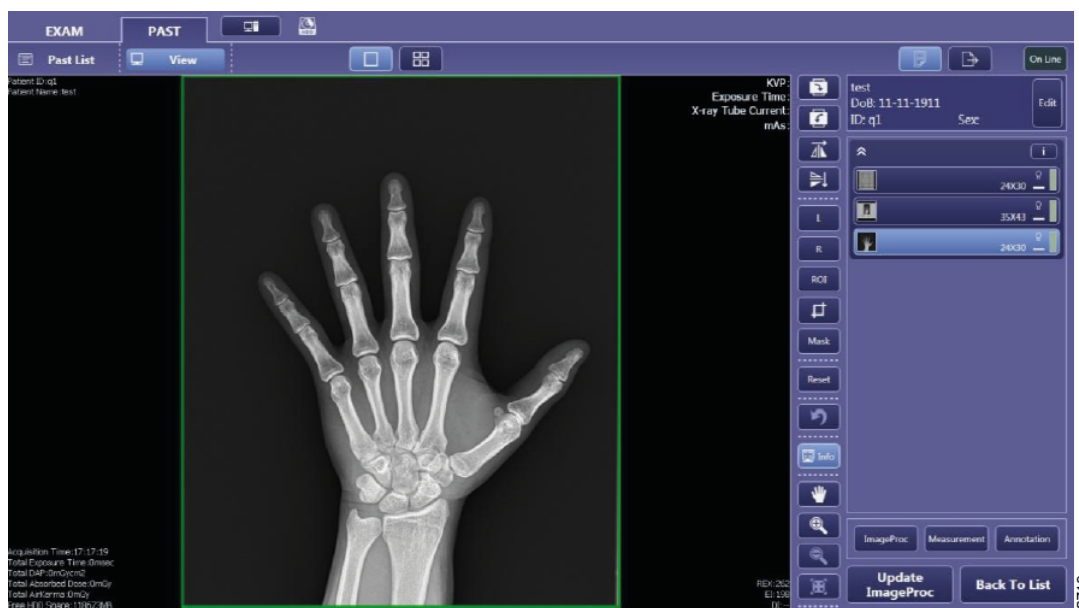



Fig. 3-94

### 3.9.8.1 Resending Images



If an image has been changed, press [Update ImageProc] and  to call the output menu.

Select [Send Image] for resending the current image only.

Select [Send Exam] for resending the complete exam containing all images.

The destinations with a checkmark are the active destinations. Changing the active destination will change it for this time only.

If [Save Setting] is pressed, the current active destinations will be set as default.

When images are being transferred to a destination a blinking cursor will be present next to the online button.



Fig. 3-95

### 3.9.9 Online - Offline

The system can work in online and offline mode.

The system is online and connected to the hospital information system and destinations. The worklist will be retrieved and when an exam has been ended, the acquired images are being sent automatically when a destination has been set.



Fig. 3-96

The system is offline, not connected to hospital information system and destinations. The worklist will show the last patient list at the time the system is set to offline.

During offline mode the acquisition computer does not refresh the worklist and acquired images will not be sent to a destination, PACS or DICOM printer.

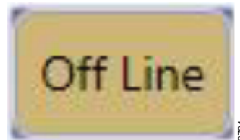

Fig. 3-97

Acquired images will stay in queue to be sent to their destinations when the system has been set to online.

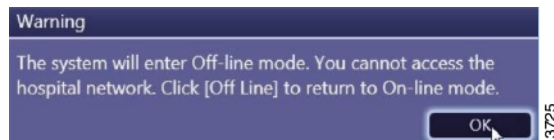

Fig. 3-98 System warning when it is put in offline mode

### 3.9.10 System View

#### *Note!*

*This information is intended for the super user.*

---

The system can be set up with a super user account. Super users have special permission for changing the system settings.

When finished as super user, remember to log off the super user account from the system.

To change protocols, the user has to be logged in with a super user account. This can be done immediately after the system is booted.

When logged into the normal user account, log out and log in again with the super user account:

1. Press the system button  to log out.
2. Press [Logout].
3. Enter the user name for the super user account.
4. Enter super user password and press [Log In].



Fig. 3-99

Ask your dealer's application specialist to create a super user account.

# User Interfaces

## Image System CXDI NE Software

### 3.9.10.1 User Administration Tab

Select the system button  to reach the system settings. Some of the system settings are available for all users; some of them are only accessible when logged in as a super user.

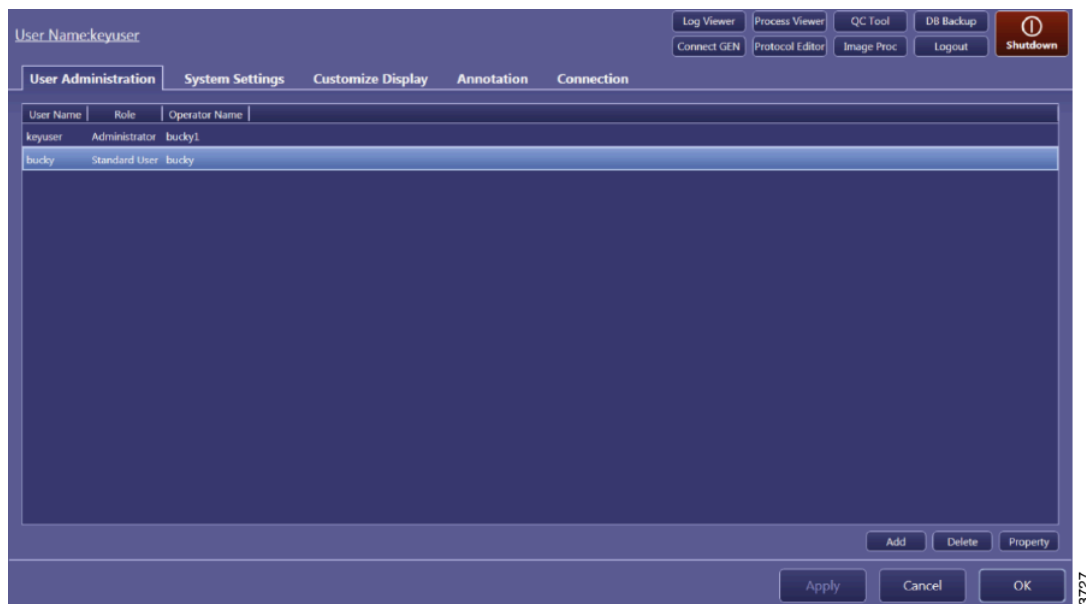

Fig. 3-100

When logged in as a super user, it is possible to see the current created user accounts in the user administration tab.

A new user account can be added via [Add].

Modify an account by clicking the button [Property].

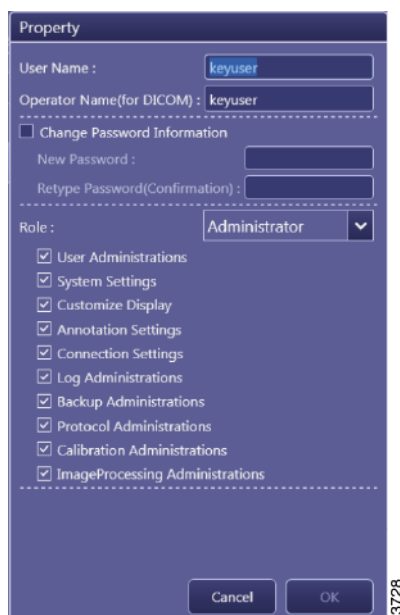

Fig. 3-101

When property is selected, the user name and operator name for DICOM can be set.

To change the password, check [Change Password Information].

Select role and choose a preset user role from the dropdown list.

To set specific privileges for each user role, contact the application specialist or service engineer.

### 3.9.10.2 System Settings Tab, Screen 1

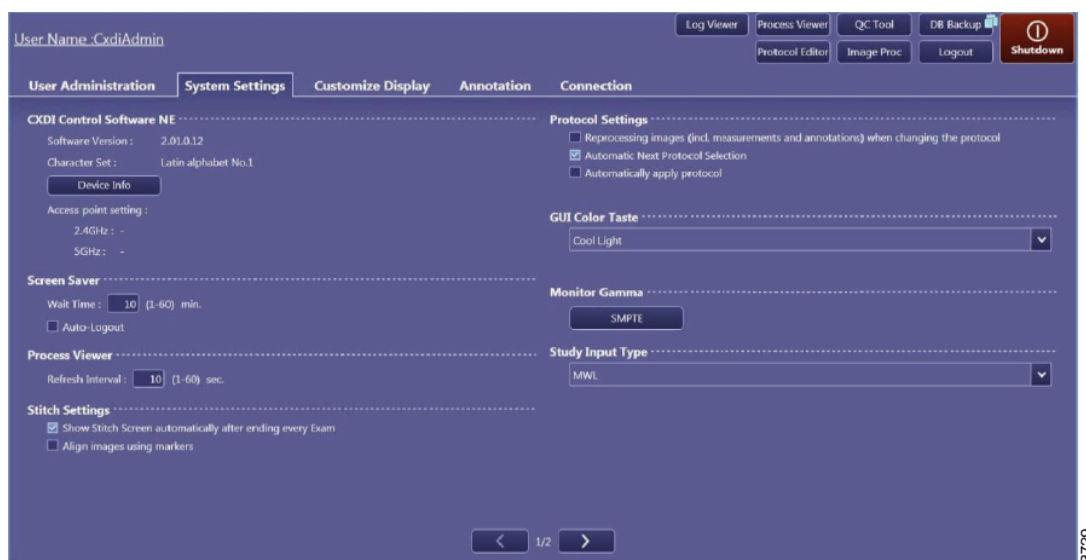

Fig. 3-102

#### **System Info**

Software version information.

#### **Screensaver**

Wait time: Turn screensaver on after x minutes.

Auto-logout: User has to log-on again when system goes out of screensaver.

#### **Process Viewer**

Refresh of the process viewer in seconds.

#### **Stitch Setting**

Show stitch...: Show stitch screen automatically when done stitch acquisition.

Align images...: Automatically align the stitch images using the reference balls in the image.

#### **Protocol Settings**

Reprocessing images: When changing the protocol all image processing will be performed again with the new image processing belonging to the new protocol.

Automatic next protocol selection: The next acquisition protocol which has not been acquired yet will be selected.

Automatically apply protocol: The auto protocol will be selected every time a patient is been registered.

#### **Gui Color Taste**

Change color settings.

# User Interfaces

## Image System CXDI NE Software

---

### **Monitor Gamma Test**

For calibration of the monitor.

### **Study Input Type**

MWL (Modality Worklist) = Use the worklist.

### **3.9.10.3 System Settings Tab, Screen 2**

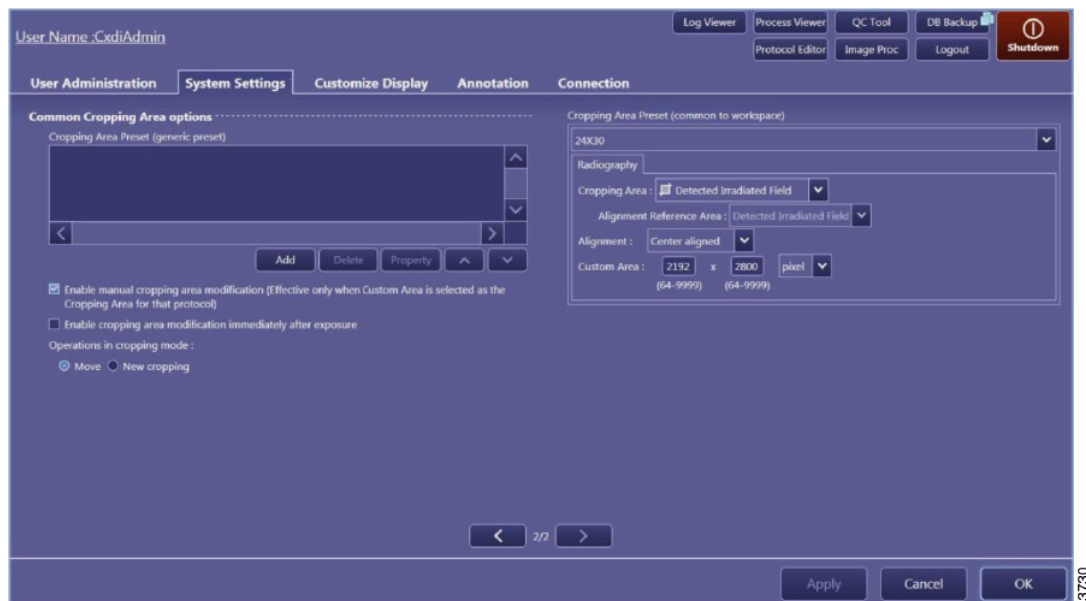

Fig. 3-103

### **Common Cropping Area Options**

**Cropping area preset:** Define the desired crop box formats.

**Enable manual cropping area:** When on, the crop box can be changed after acquisition. When off, the crop box cannot be changed after acquisition.

**Enable cropping area modification immediately after exposure:** When enabled, after exposure it is possible to immediately crop the image without turning on the crop function.

**Operations in cropping mode:**

**Move:** After selecting the crop mode the default action is moving to crop box.

**New cropping:** After selecting the crop mode the default action is changing the crop box in size.

### 3.9.10.4 Customize Display Tab, Screen 1

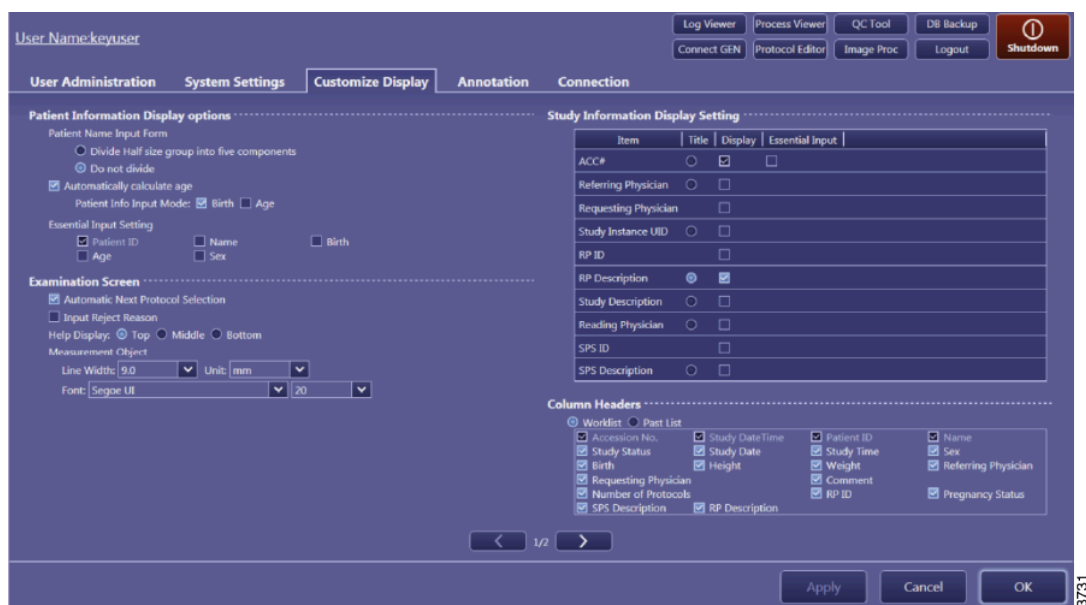

Fig. 3-104

#### **Patient Information Display Options**

Default set to do not divide.

#### **Essential Input Setting**

Which patient information fields are mandatory.

#### **Examination Screen**

Automatic next....: The next acquisition protocol which has not been acquired yet will be selected.

#### **Help Display**

Location where dialogue from the system will be displayed.

#### **Measurement Object**

Settings for measurements.

#### **Study Information Display Setting**

Title: Information field which will be displayed as study header.

Display: Information fields which will be displayed when the  within a study is pressed.

Essential input: Mandatory to fill these fields with information.

#### **Column Headers**

The checked information fields will be displayed in the selected list (worklist or past list).

### 3.9.10.5 Customize Display Tab, Screen 2

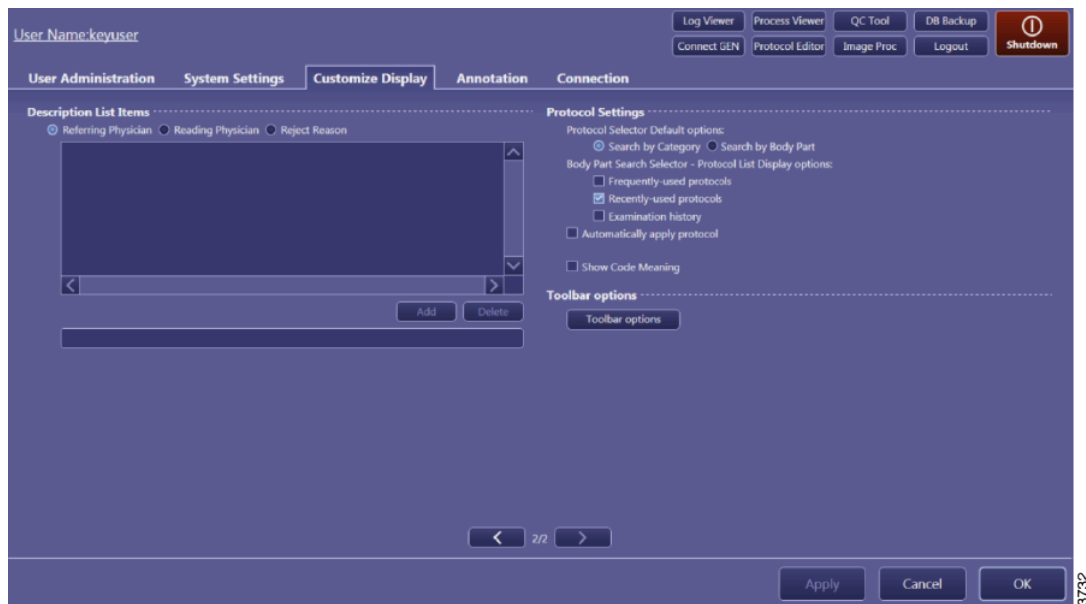

Fig. 3-105

#### **Description List Items**

For each item a preferred list can be made. Users can choose an item from the list.

#### **Protocol Settings**

Search by category: -search an acquisition protocol via tabs.

Search by bodypart: -search via anatomical diagram.

#### **Toolbar Options**

Divide and order the several tools between toolbar #1 and toolbar #2.



### 3.9.10.6 Annotation Tab

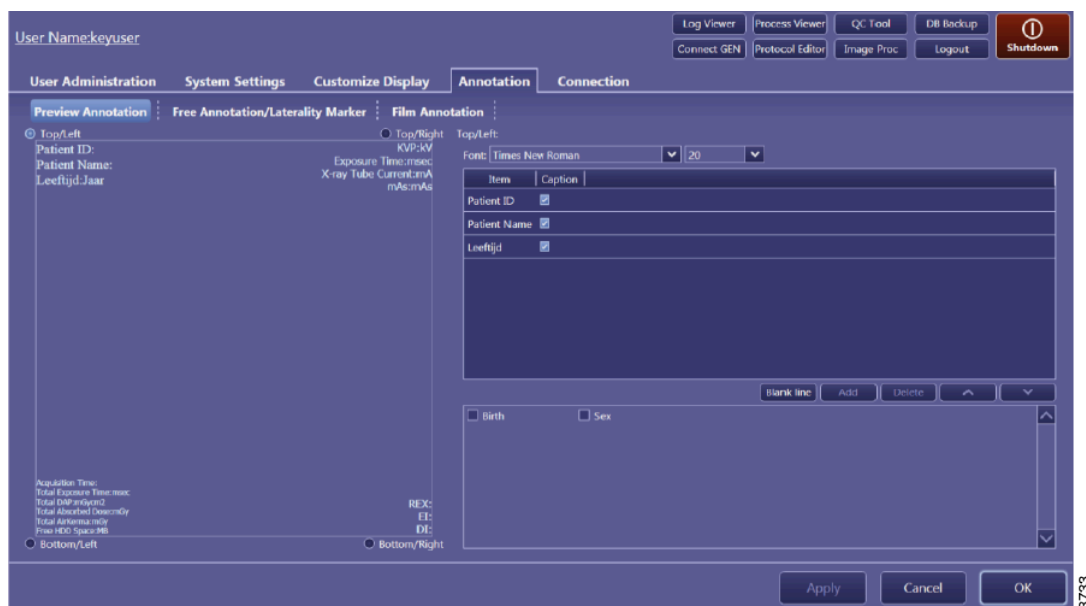
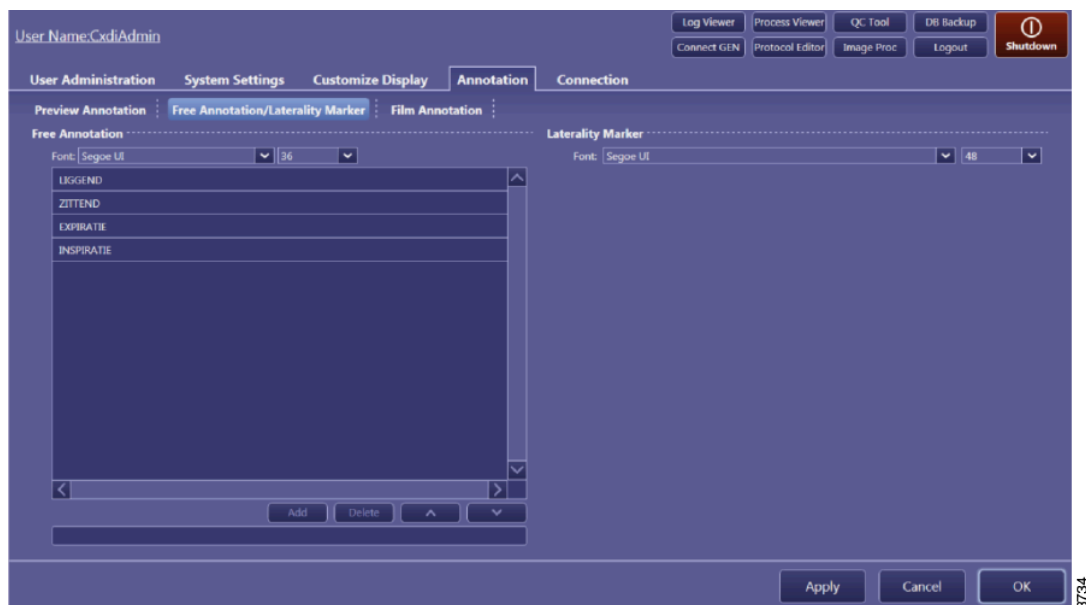

Fig. 3-106

#### Preview Annotation

Select top/left, top/right, bottom/left or bottom/right.



#### Free Annotation / Laterality Marker

Free annotation: List with preprogrammed annotations

Laterality marker: Font and size of the left and right marker. The position of the marker is set per protocol in the protocol editor.

### 3.9.10.7 Connection Tab

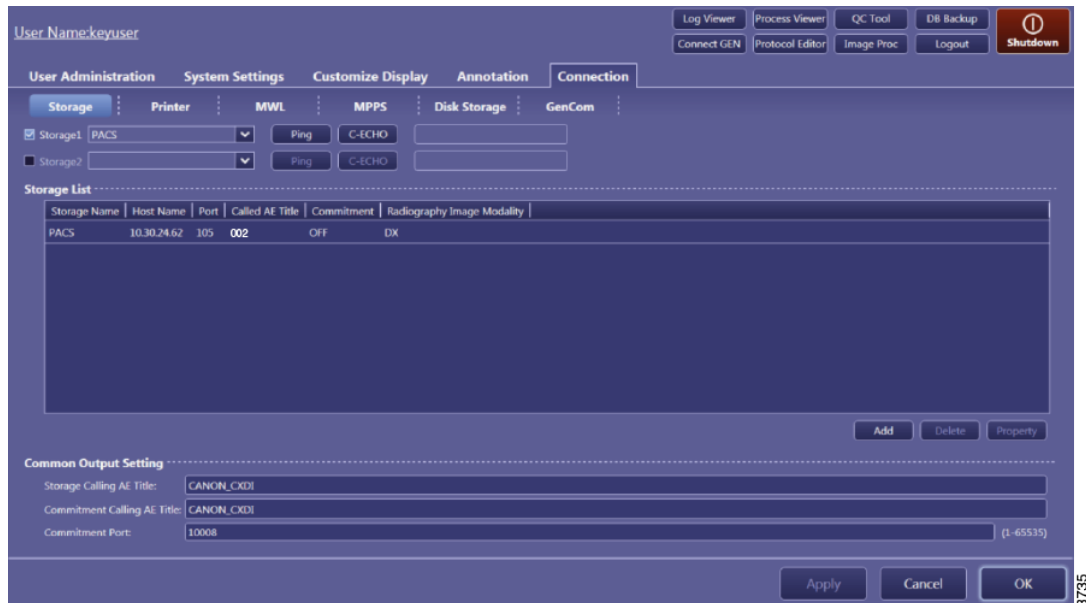

Fig. 3-107

#### **Storage**

Settings for sending to destination PACS.

#### **Printer**

Settings for sending to destination printer.

#### **MWL**

Settings for retrieving a worklist from a modality worklist (MWL) server.

#### **MPPS**

Settings for the modality performed procedure step (MPPS).

#### **Disk Storage**

Settings to export images to a DICOM DIR folder.

#### **GenCom**

Settings for the x-ray generator.

### 3.9.10.8 Protocol Editor

The protocol editor and image protocol buttons can be used only if no patients are active in the worklist and the past list.



Fig. 3-108

Press the system button to show the [Protocol Editor].

With the protocol editor a protocol can be modified.

The following can be modified:

- Name and position of a protocol.
- Name and position of the tabs.
- Prepacked protocols.
- DICOM information.
- Default workspace, important if attached to a RIS code.
- Preferred orientation of the image after acquisition.
- Crop settings.
- Film options, if printed to a DICOM printer.
- Exposure settings, Kv, mAs, AEC, Focus size.

# User Interfaces

## Image System CXDI NE Software

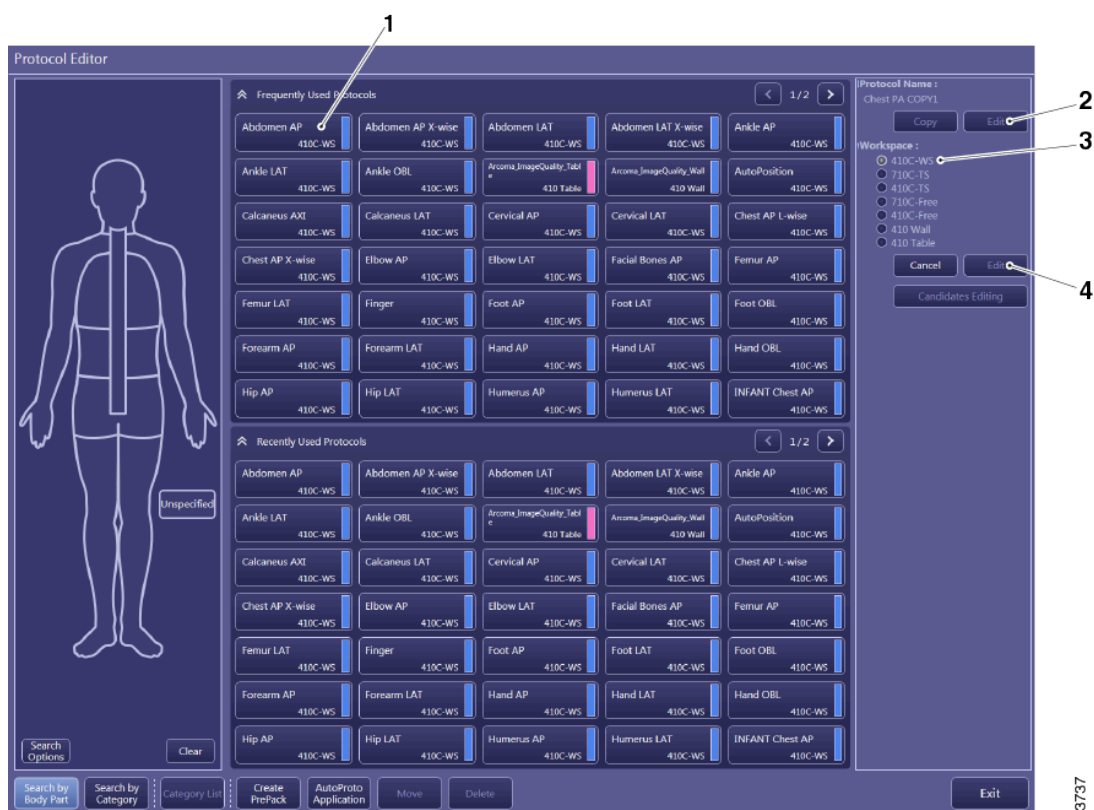

Fig. 3-109

1. Select protocol
2. Copy and simple edit
3. Selected workspace
4. Set and advanced edit

After selecting protocol editor the Triathlon T3 will display several tabs and protocols. This is called the button layout.

The button layout can show protocols with their corresponding workspaces. In this case all C-ARM workspaces are displayed on the left side of the screen and the 35X43 workspace are displayed on the right side of the screen. Show only the most used workspace in the button layout.

To modify a workspace from a protocol, which has not been placed into the button layout, select the workspace between the simple and advanced [Edit]. By selecting the workspace, modify the protocol for that workspace or set a button in the button layout with [Set].

### Move a protocol

Select the protocol and press [Move]. All empty slots will be highlighted. Click an empty slot to move the selected protocol to that empty slot. It is also possible to move to another tab.

### Delete a protocol

Select the protocol and press [Delete].

### Add a New Protocol

To add a new protocol, make a copy from a similar protocol. The duplicate can be modified into the desired protocol. Image processing is changed with image proc.

This manual will show how to make a new protocol named "CHEST PA". This will be made from the original "CHEST PA".



Fig. 3-110

Select the original protocol and press [Copy].



Fig. 3-111

Confirm that a copy from "CHEST PA" has been made.

Be aware that this protocol still is not visible in the button layout.

Notice that the system now has selected the new copy.

Press [Edit] to rename the protocol.



Fig. 3-112

Give the new protocol a new name, in this case "CHEST PA"

# User Interfaces

## Image System CXDI NE Software

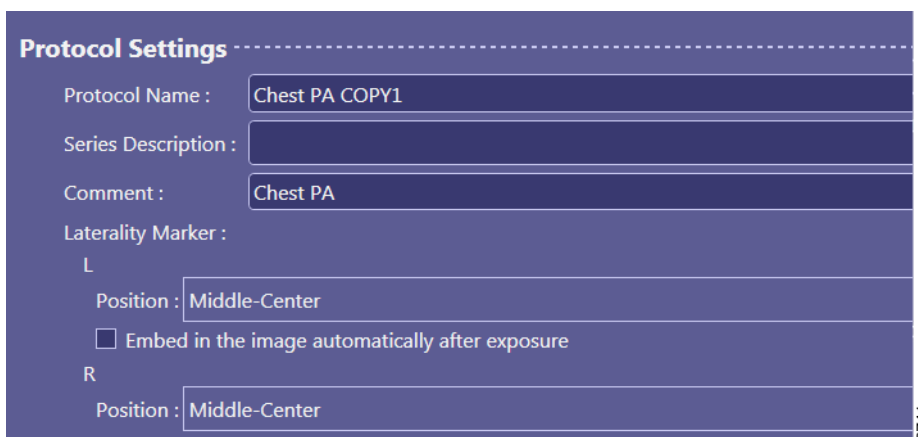

Fig. 3-113

Select the default workspace; this is important if the protocol is directly linked to a RIS code. Press [OK].

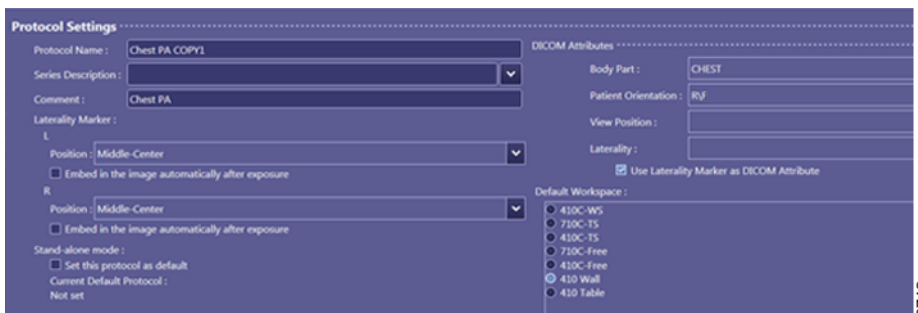

Fig. 3-114

For every workspace an acquisition protocol button can be placed onto the button layout. Select workspace and press [Set] to place the new protocol into the button layout.

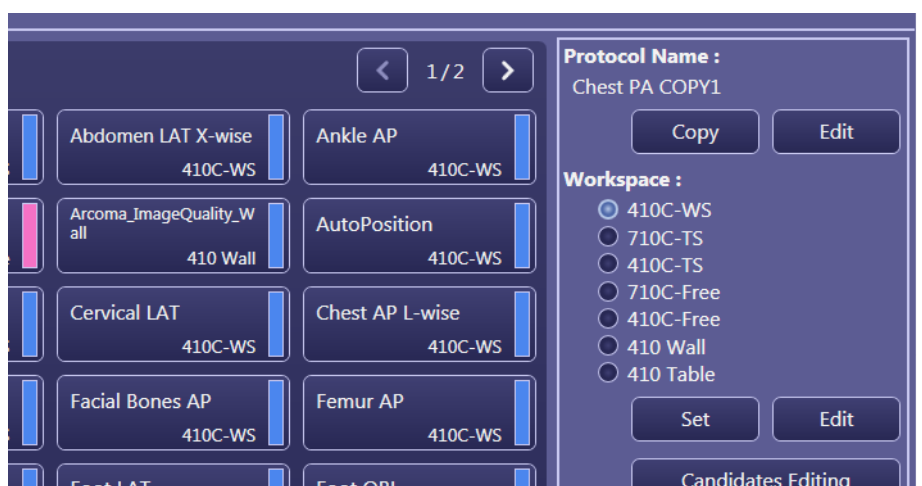

Fig. 3-115

All empty slots are highlighted and an empty one can be assigned.

# User Interfaces

## Image System CXDI NE Software

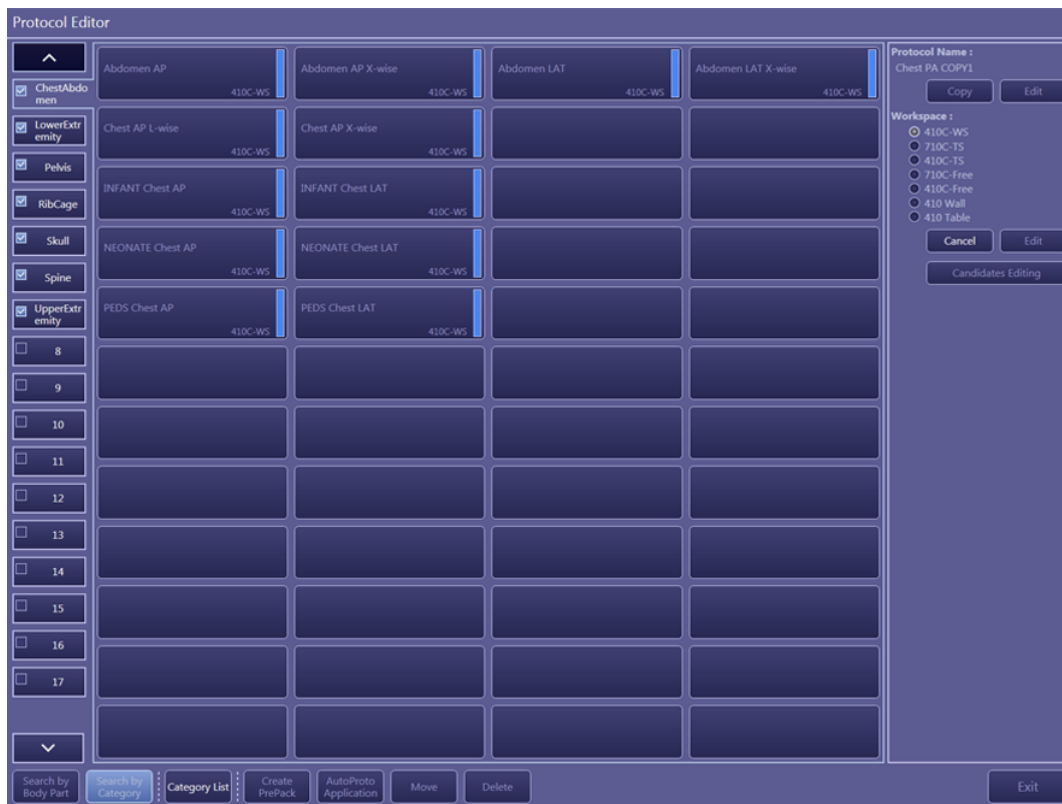

Fig. 3-116

The first workspace for "CHEST PA" has been assigned onto the button layout.

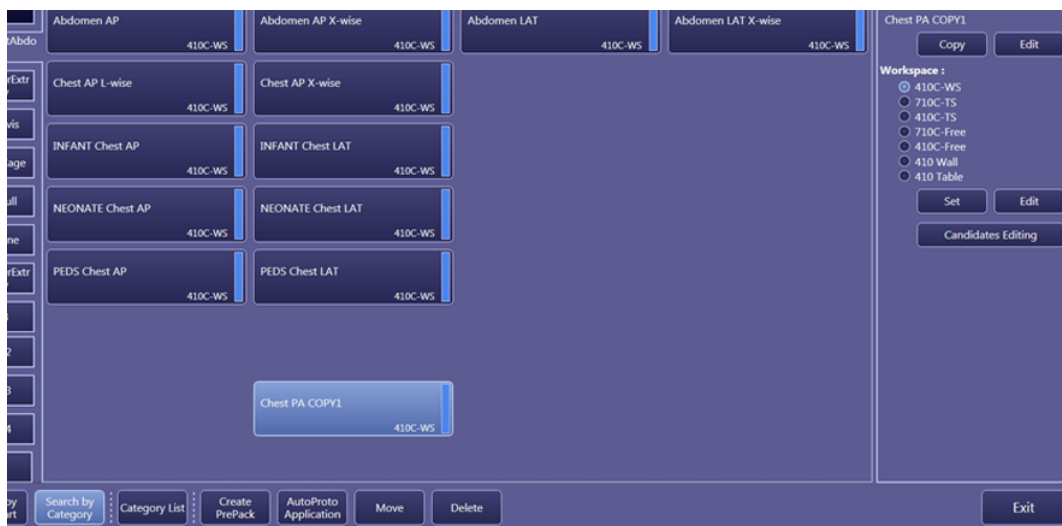

Fig. 3-117

Repeat this for all other workspaces.



Fig. 3-118

# User Interfaces

## Image System CXDI NE Software

Select one of the new workspaces and press on [Edit] next to the [Set] button.



Fig. 3-119

Change settings if desired, press [Next].

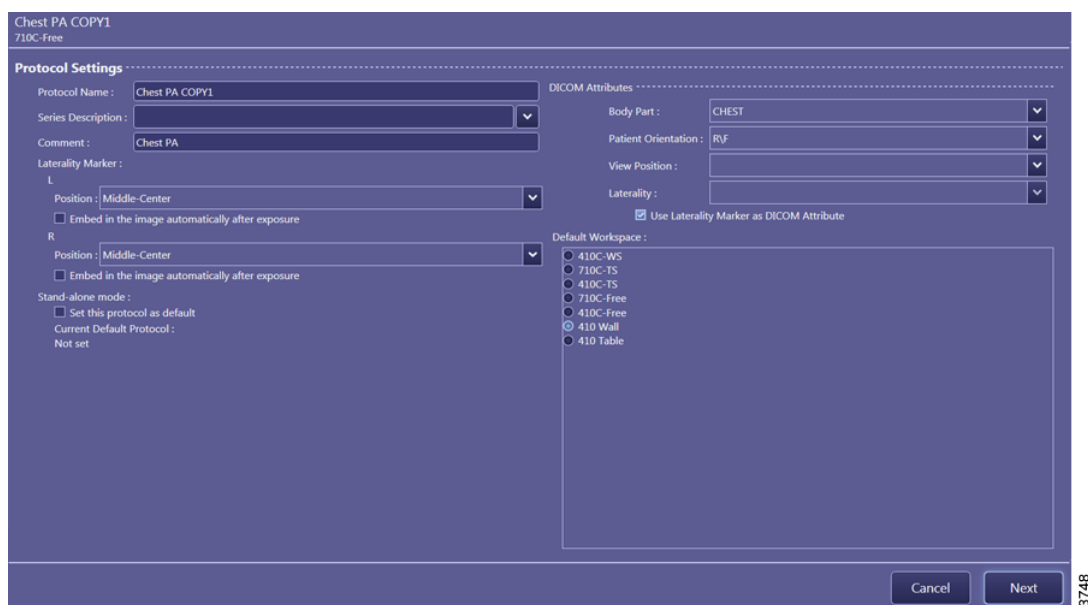

Fig. 3-120

For a PA protocol it is necessary to modify the orientation at “Flip and Rotate”. This has to be done for every single workspace for this protocol.



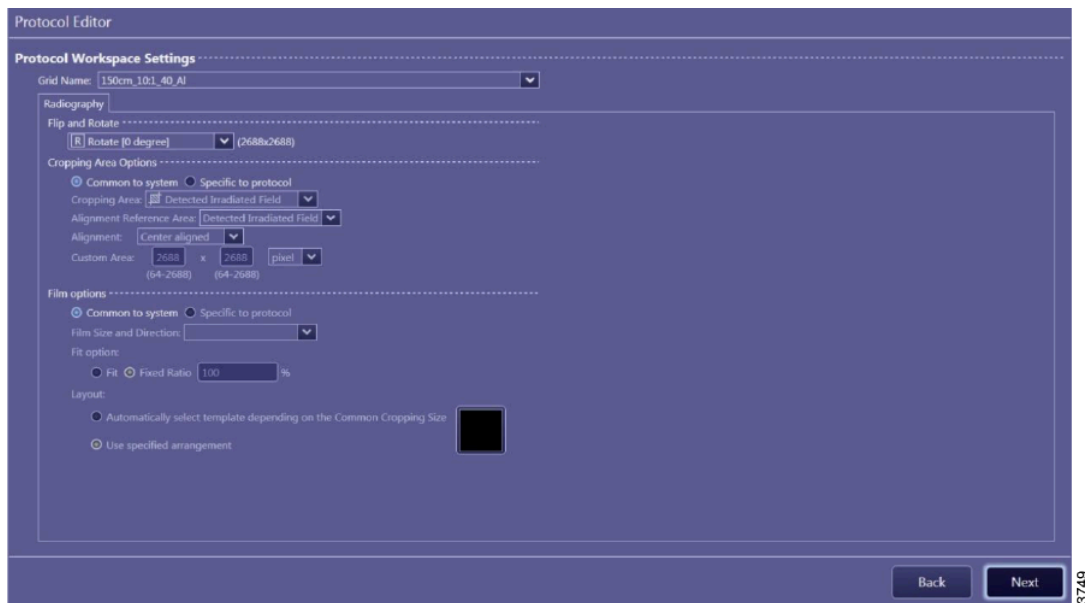



Fig. 3-121

For a PA protocol the “Flip and Rotate” has to be set on . The rotation is room specific. Check orientation and set correctly.

Press [Next] for next screen.

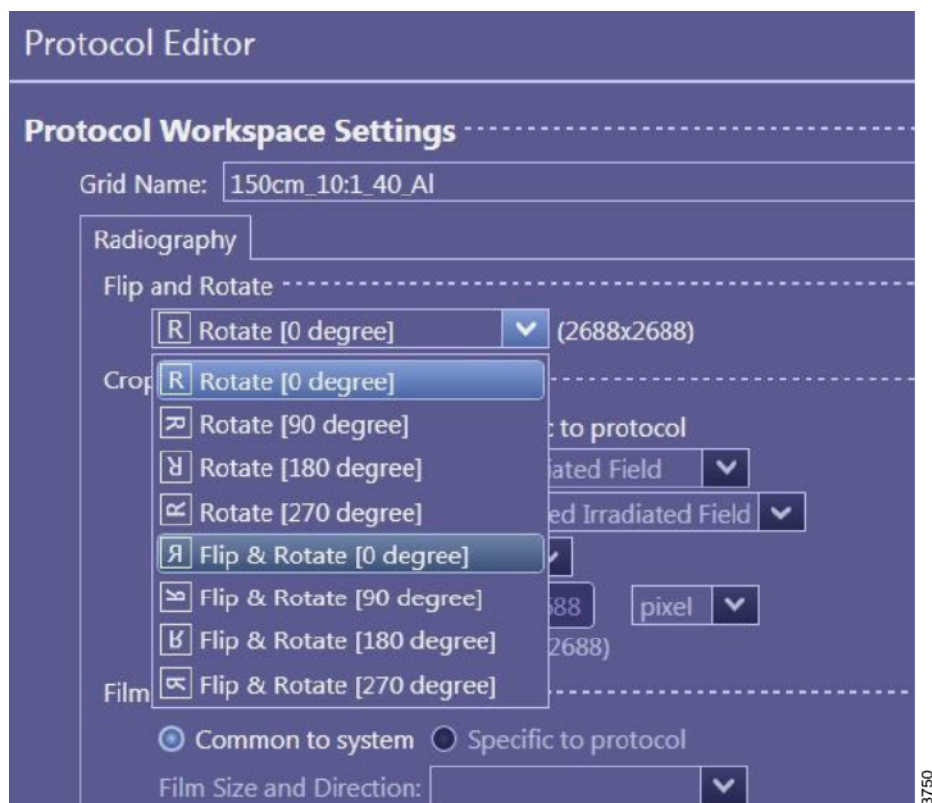

Fig. 3-122

In the generator screen, exposure settings can be changed.

# User Interfaces

## Image System CXDI NE Software

Be aware that changing kV has to be confirmed with [Enter] on the keyboard.

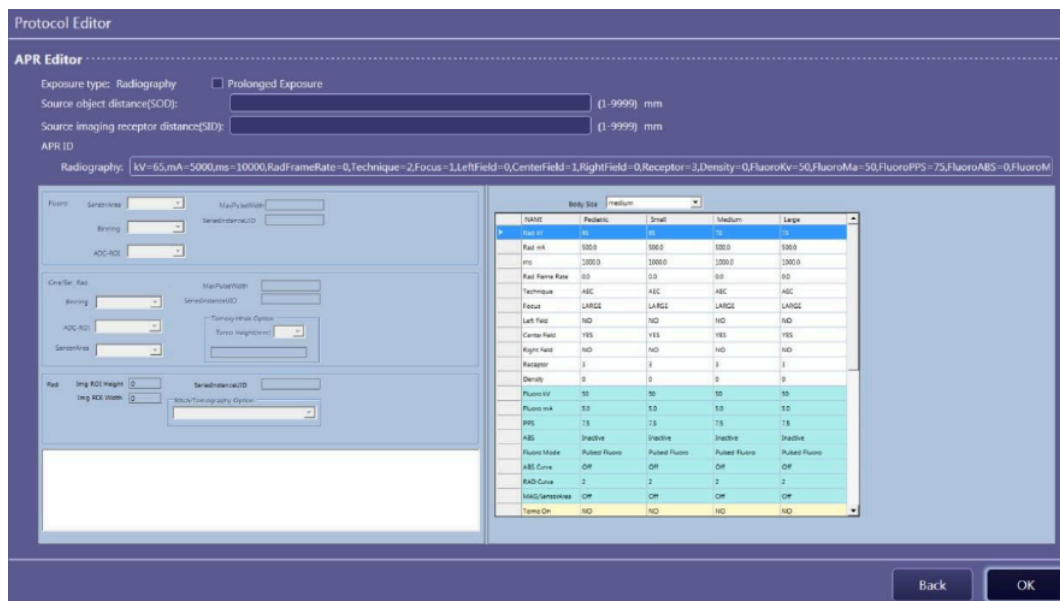

Fig. 3-123



### **WARNING!**

**Exposure settings can be set which can exceed the power limitations of the x-ray tube or generator.**

**Always test in advance in normal acquisition mode if a combination of exposure settings with the desired focus size is possible.**

**If AEC is set, the system will use the mA and mSec as the backup limit, so set up these parameters accordingly.**

### *Settings X-ray Generator*

For x-ray generator settings, see figure in **Table 4-4**.

# User Interfaces

## Image System CXDI NE Software

### Modify a Tab

The system can contain up to 50 tabs, These tabs represent the different body categories.

The name and order can be modified. It is also possible to switch on or off a tab by a super user. A switched off tab will not be visible for a user with standard privileges.

### Modify Name and Order of a Tab

Select in the protocol editor the button [Category List] for displaying a list with all category tabs.



Fig. 3-124

Select a tab name and press one of these buttons to rename or re-order:



Fig. 3-125

### Hide or Unhide Tab for Standard Users

Tab checked: Visible for standard users.

Tab unchecked: Not visible for standard users.

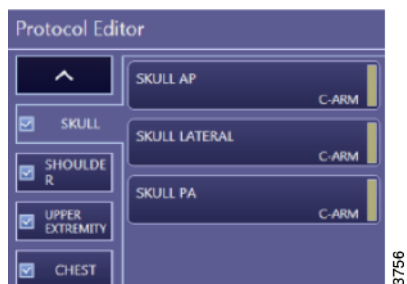

Fig. 3-126

### 3.9.10.9 Modify Image Processing

Adjusting image processing can have a great impact on image quality. Let radiologist decide if the image processing is set to satisfying results. If protocols are modified, remember to

track which protocols have been changed and do so for all other workspace protocols belonging to the same protocols.

Press [Image Proc] to change image processing.



Fig. 3-127

Select the protocol/workspace and press [Edit Radiography].



Fig. 3-128

# User Interfaces

## Image System CXDI NE Software

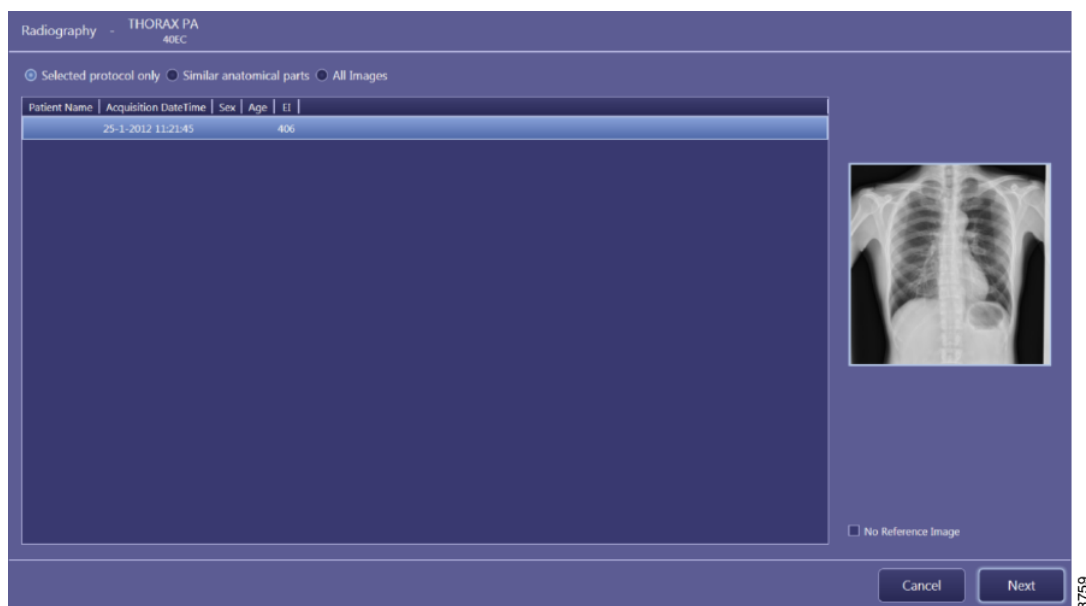

Fig. 3-129

All images acquired with the selected protocol will be shown in a list.

Select one for reference or check [No Reference Image] if a reference image is not available or necessary.

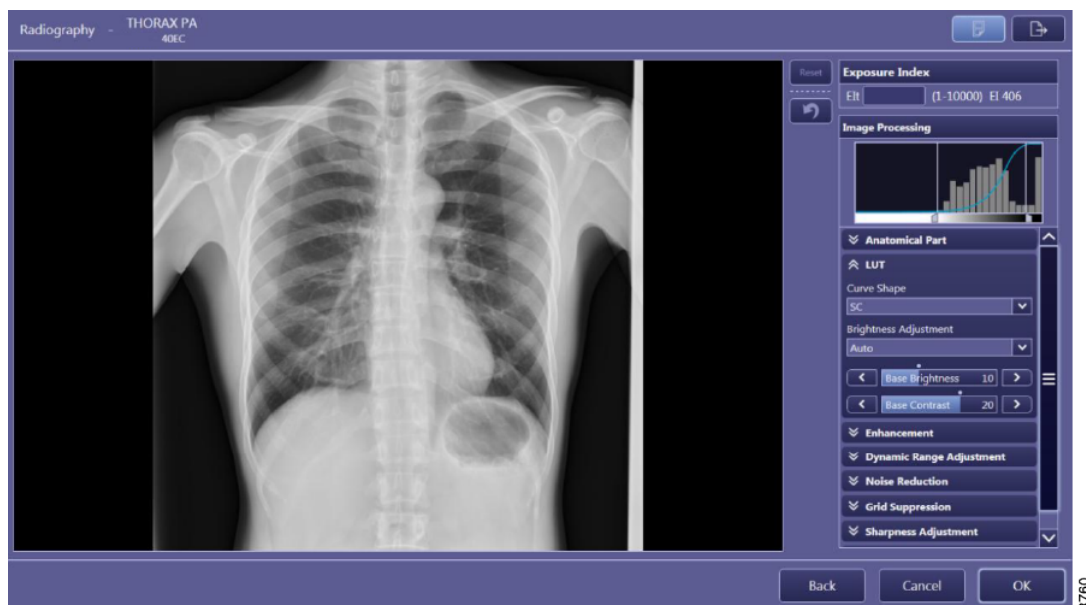

Fig. 3-130

In several image processing categories the image processing can be modified.

When modification has been set to a satisfactory level and press [OK].

The modification is set directly, no confirm dialogue will be displayed.

### **Image Processing: The parameters**

Image processing is divided in several user levels. The example shown here shows the image processing on level 3, where the user has rights to adjust all parameters.

### User Levels

The normal user has privileges for level 1 only; this means that brightness and contrast can be modified only.



Fig. 3-131

### Anatomical Part

The anatomical part describes the part / organ for the system.

This means that the system will set its automatic region of interest according to the anatomical part. If set on chest, it will display the image with optimized brightness for lung tissue.

If set on thoracic spine, it will display the image with optimized brightness for spine. With adjusting the base brightness the image can be optimized.

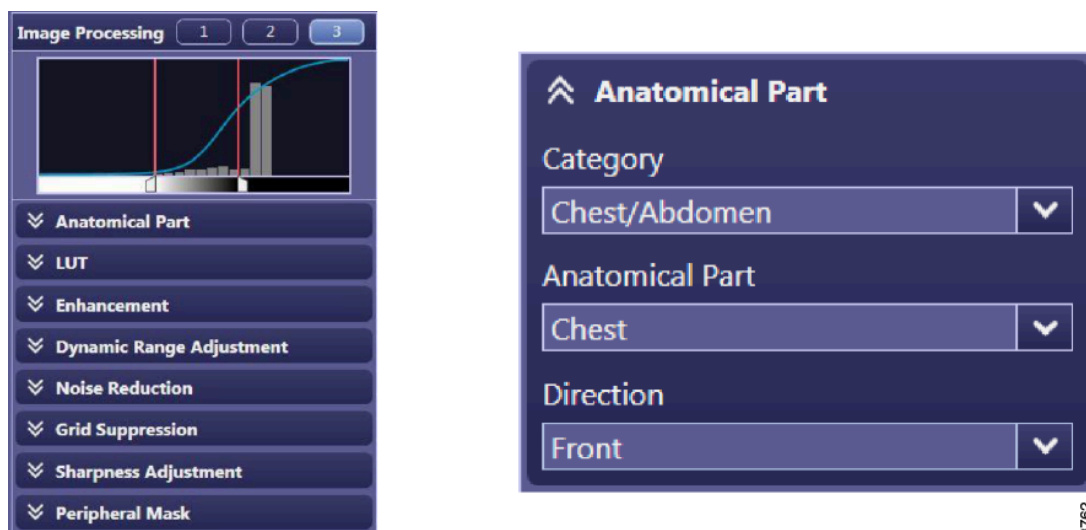

Fig. 3-132

### LUT

The base brightness and base contrast are the "real" brightness and contrast. These values are not visible for normal users on level 1.

# User Interfaces

## Image System CXDI NE Software

---

Normal users will see brightness and contrast, which will be set on “0” always directly after image acquisition. Changing brightness and contrast is just an offset from the real base brightness and base contrast. Whenever an image in the past list has not 0 for brightness or contrast it is visible that the image has been modified.

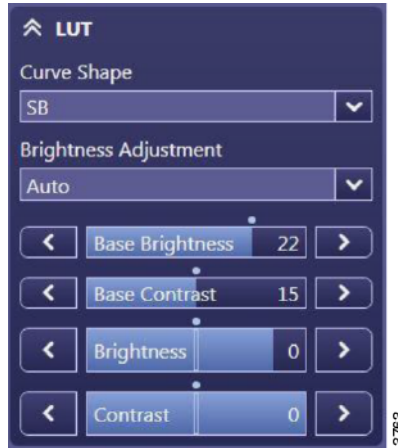

Fig. 3-133



### Curve Shape

Each LUT has its own characteristics for brightness and contrast.

There four different tables are SA, SB, SC and LN.

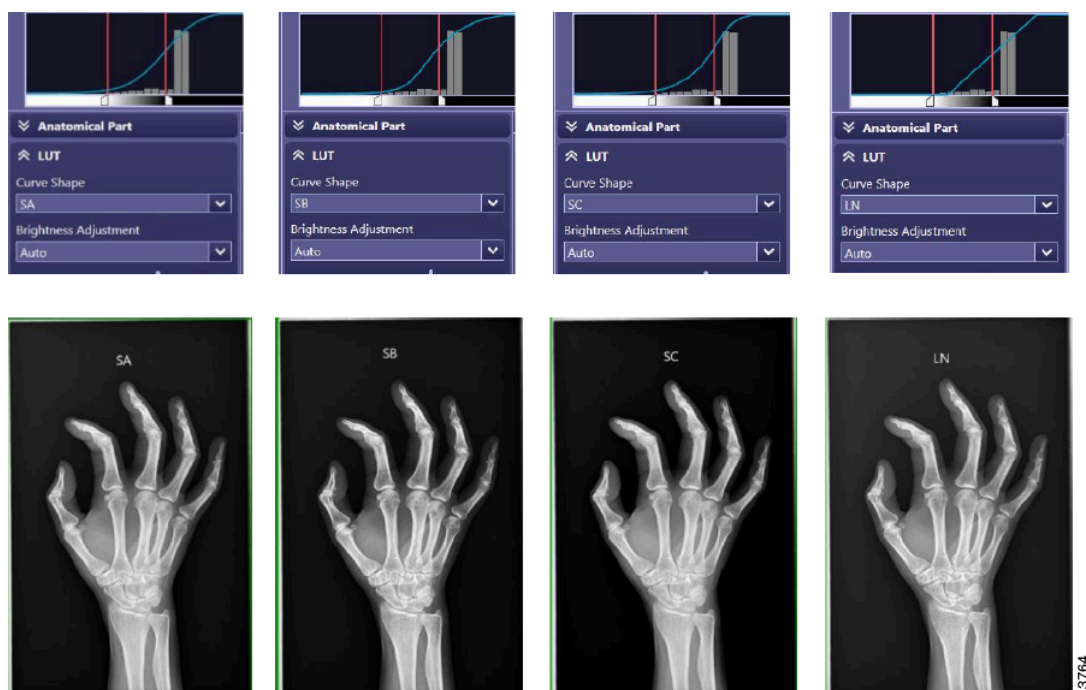

Fig. 3-134

### Enhancement

Edge enhancement: 1=minor, 20=major

Edge frequency: 1=large structures, 7=small structures

Contrast boost: 1=minor, 20=major

Dynamic range compression deteriorates the local contrast.

Contrast boost will compensate for the deterioration.



Fig. 3-135

### Dynamic Range Adjustment

Dynamic range adjustment consists of two parameters: Dark region and bright region.

An image will be optimized first by the anatomical part, which will place the LUT within the histogram on the region of interest (ROI).

# User Interfaces

## Image System CXDI NE Software



3766

Fig. 3-136

A minor shift takes place for setting the correct base brightness.

All information to the right side of the LUT is dark region. All information to the left side of the LUT is bright region. With these two parameters the dark and bright regions can be modified.

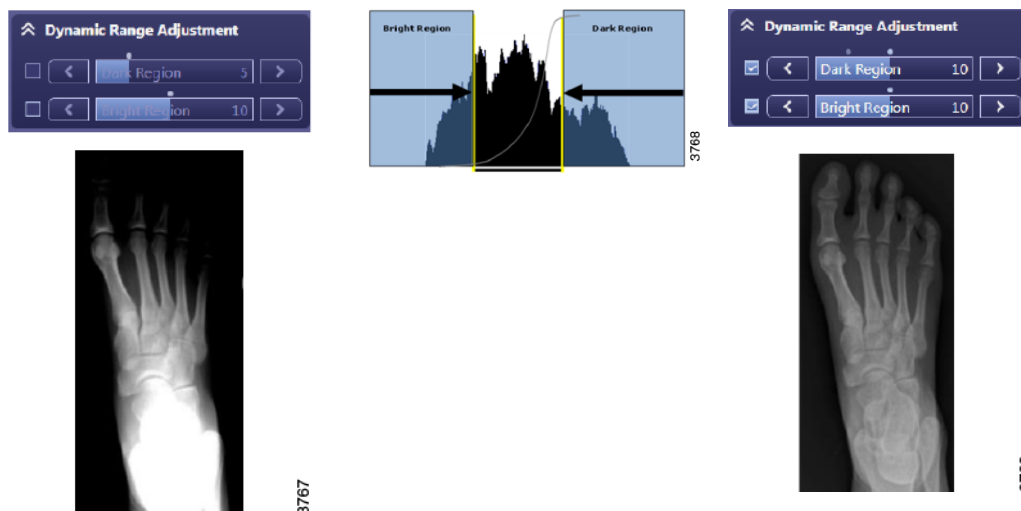

3767

3768

3769

Image without dynamic range adjustment.

Adjust image in bright and dark area by data compression left and right from LUT.

Image with dynamic range adjustment.

### **Noise Reduction**

Noise reduction: 1 minor effect. 10 major effect.

Use it wisely; noise reduction also blurs the image.

This can be used for low dose, like age prognosis or hip dysplasia.

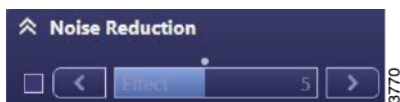

Fig. 3-137

### **Sharpness Adjustment**

With sharpness adjustment small structures can be seen more clearly. This is more obvious on a PACS monitor than on the acquisitions screen.

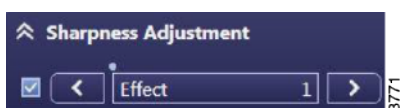

Fig. 3-138

### **Peripheral Mask**

With peripheral mask the area outside the exposed surface is made black.

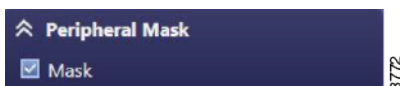

Fig. 3-139

### 3.9.11 Detector Status

The status of the detectors is shown with a green light in the upper, right corner.

The information is remaining battery time, signal strength and if the detectors are ready for exposure.

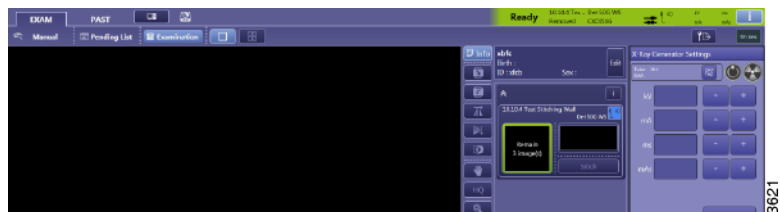

Fig. 3-140

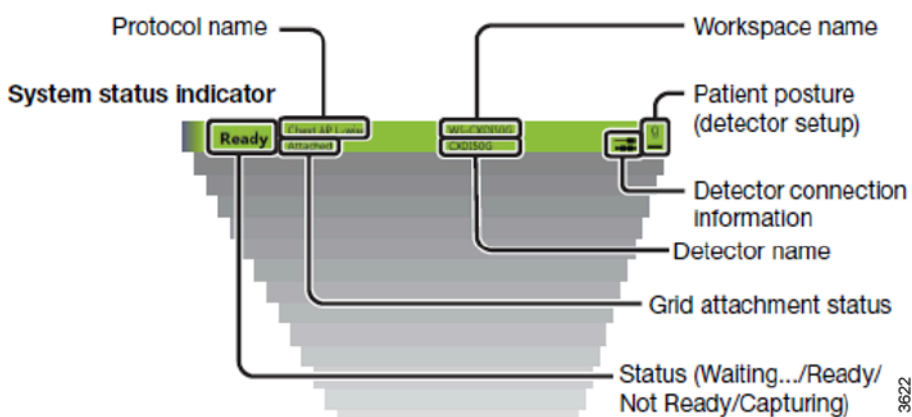

Fig. 3-141

#### 3.9.11.1 Battery Status

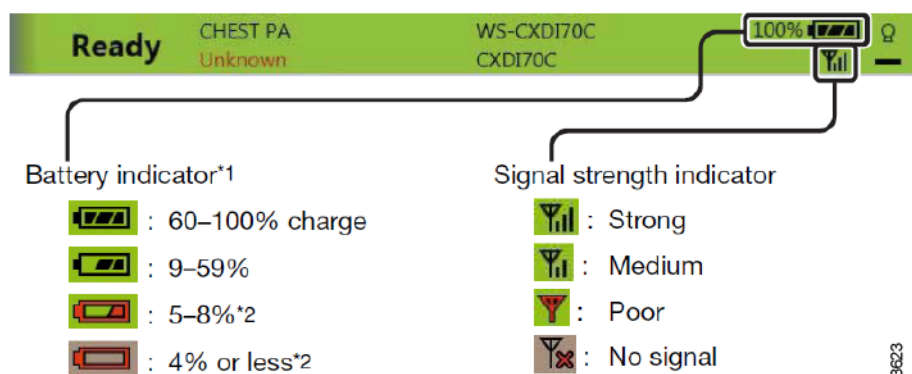

Fig. 3-142

## 4 Operating the System

### 4.1 General



#### **WARNING!**

---

*If any item is removed from the wallstand, e.g. the detector or lateral armrest, the wallstand will become unbalanced.*

*When the brake is released, part of the wallstand will move upward and can cause injury.*

*The operation should be performed by trained personnel.*

---



#### **WARNING!**

---

*All motorized movements shall be supervised by trained personnel.*

---



#### **WARNING!**

---

*The detector, FPD (flat panel detector) and grid should be installed properly.*

*Handle with care.*

---

#### **CAUTION!**

---

*Keep the control devices out of reach for the patient.*

*Move the devices away from the patient when not in use.*

---

#### **CAUTION!**

---

*When the system is switched off, wait at least 15 seconds before switching it on again.*

---

#### **Note!**

---

*The system shall only be operated by trained radiologist, service technicians or product specialists.*

---

The system is manually moved, except for the up and down movements of the OTC, the table and the motorized wallstand (option). These movements are motorized.

The standard equipment includes a graphic display showing X-ray tube rotation (Alpha), Source Image Distance (SID), height, patient information, selected workstation, exposure parameters and Automatic Exposure Control (AEC).

The table has a floating table top with a large moving range. The table has features such as a low load position and fast positioning.

# Operating the System

## General

---

The wallstand has either a detector holder for a fixed or portable detector. The wallstand has a motorized option.

### 4.2 Turn on the System

The system is ready for examination within two minutes after the system has been turned on.

Before starting the system, check that the emergency stop is not activated.

When the system starts up, light indications and displays are lit.

Perform the following procedure when starting up the X-ray system:

Fig. 4-1 Power on button – mini console

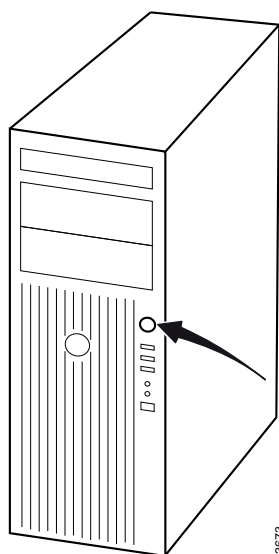

1. Press the power [ON] button (A) on the mini console.
2. Press the power button on the computer.
3. Start the display.

Fig. 4-2 Power button – image control unit

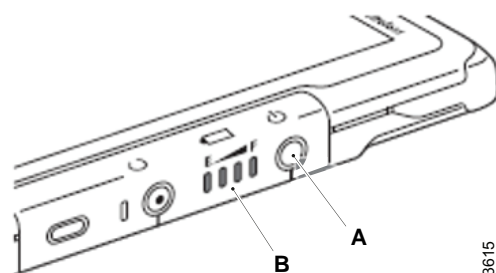

4. Start the wireless detector (option), press the power button (A).  
The power-LED (B) lights with a fixed light.

Fig. 4-3

# Operating the System

## Turn on the System

- 5. Log in on the computer.
- 6. Type user name and password, press Log in.



Fig. 4-4

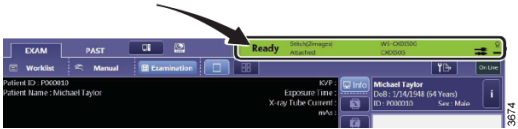

Fig. 4-5

- 7. Confirm that the image system has started normally by checking the status icons.



### 4.3 Turn off the System

*Note!*

*Wait for two minutes or longer after the examination is completed before turning OFF the power.*

1. Move the OTC to a parking position, for example over the table.
2. Turn off the image system  3611.

Select  3612.

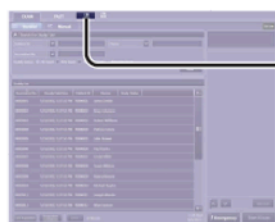

[EXAM > Worklist] screen

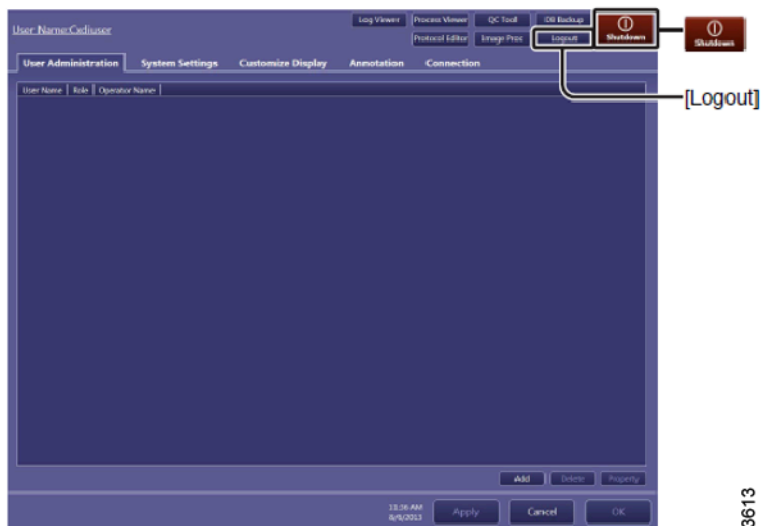

Fig. 4-6



Fig. 4-7

# Operating the System

## Turn off the System

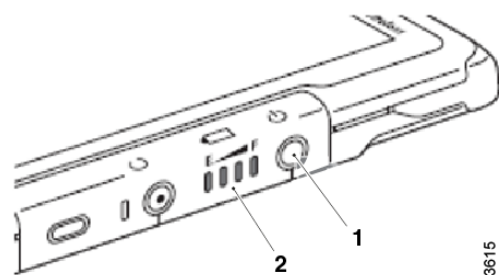

3815

Fig. 4-8

3. Turn off the wireless detector (1).

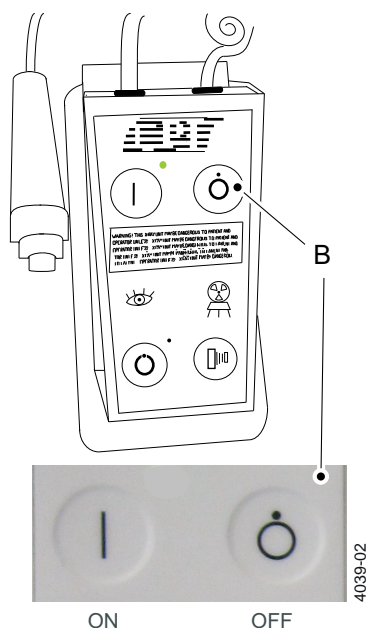

Fig. 4-9 Power button off – mini console

4. Press the power [OFF] button (B) on the mini console.

It is possible to turn off the power to the X-ray system while the power to the image system is still on.

### 4.4 Perform Examination

#### 4.4.1 Select Patient

1. Select [Exam] and [Worklist].



Fig. 4-10

2. Sort the list in [Search For Study List] and select patient.

#### 4.4.2 Start Examination

1. Select [Start Exam].

Predefined protocols are activated automatically.

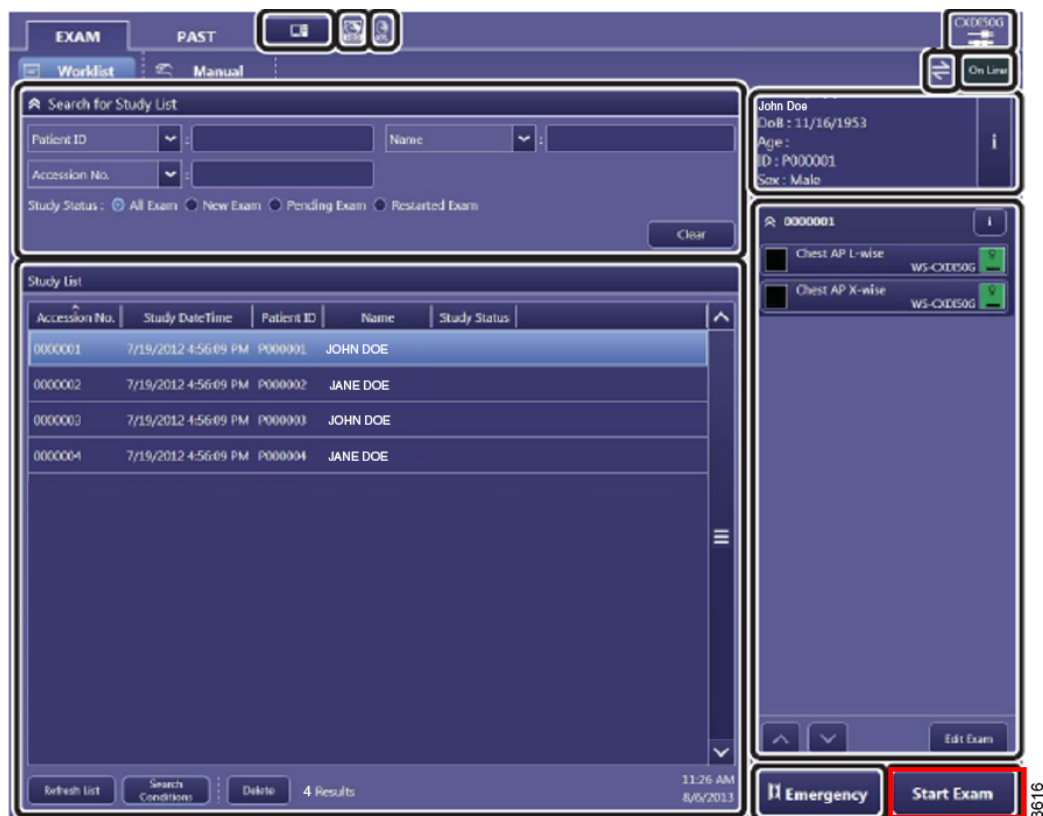

Fig. 4-11

# Operating the System

## Perform Examination

---

### 4.4.3 Workstation Indication Light

- 1. The indication light will be lit on the selected workstation.

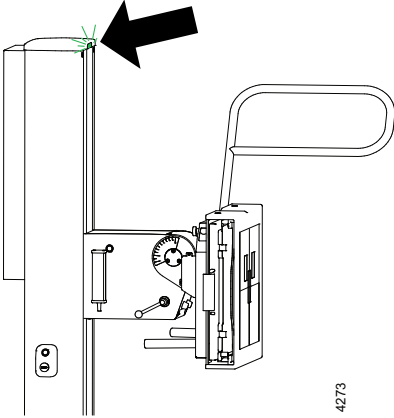

Fig. 4-12 Wallstand indication light

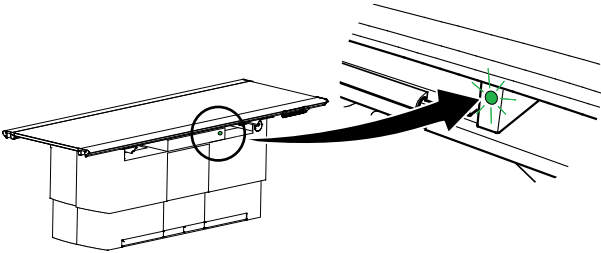

Fig. 4-13 Table indication light

### 4.4.4 Position OTC and Wallstand

1. Align the OTC to the centre of the wallstand detector.

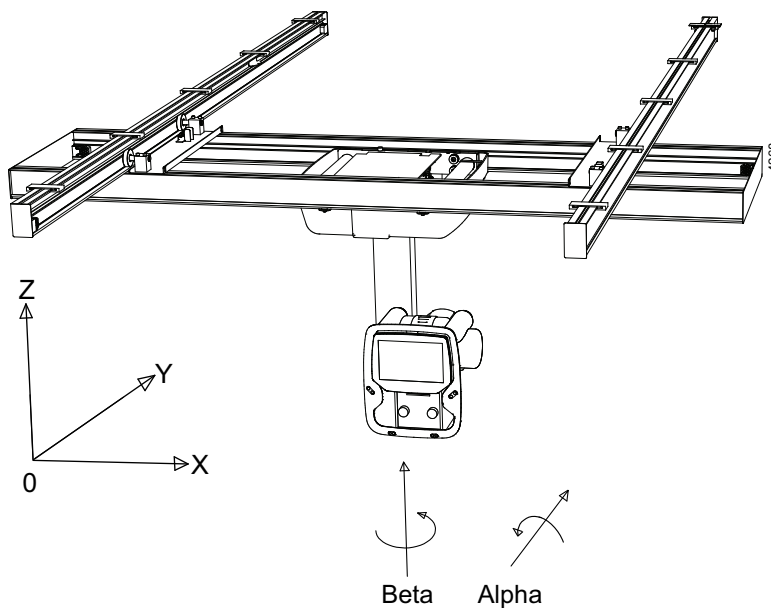

Fig. 4-14

2. Move the OTC to the correct SID according to the selected protocol.

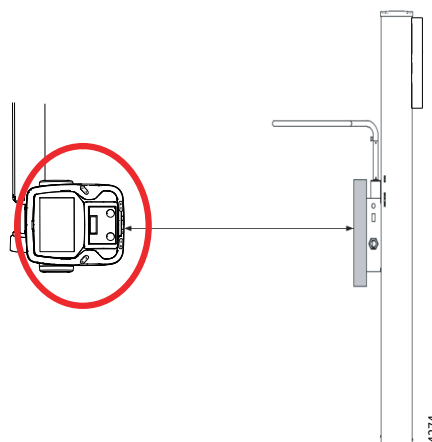

Fig. 4-15

3. Select *Auto Tracking* on the OTC display.
4. Press the *Synchronization button* on the Wallstand console or press up/down button on the OTC as indicated with blue arrow.  
The indication light indicates, with a fixed light, that the system has reached the correct position.

# Operating the System

## Perform Examination

---

### 4.4.5 Position OTC and Table

1. Pull out the table detector holder.

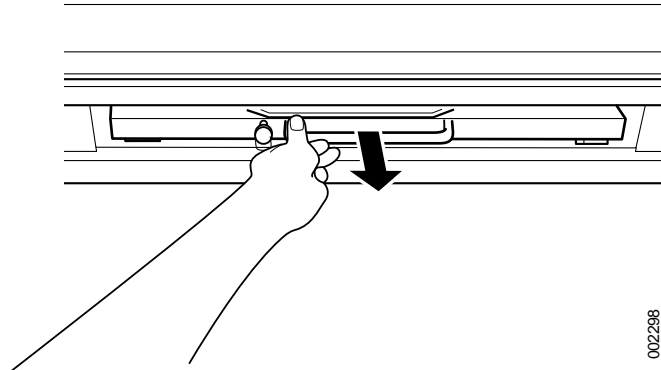

Fig. 4-16

2. Use the collimator light to align the OTC. Aim at the centre of the detector holder handle.
3. Move the OTC to index position to the centre of the table.

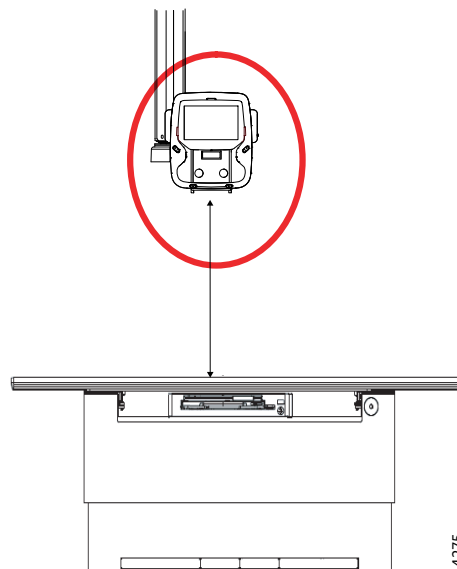

Fig. 4-17

4. Select *Auto Tracking* on the OTC display.
5. Press the up/down button on the OTC according to indicated by blue arrow in the OTC display.  
The indication light indicates, with a fixed light, that the system has reached the correct position.

### **4.4.6 Adjust Position and Collimator For Chosen Examination and Patient**

Adjust the position of the OTC, table top or wallstand according to:

- **3.4 OTC Control Elements, Page 83**
- **3.8 Table Control Elements, Page 92**
- **3.3 Wallstand Control Elements, Page 80**

The light field should be reduced to the examination area. Adjust the collimator according to:

- **3.5 Manual Collimator, Page 84**
- **3.6 Automatic Collimator (option), Page 85**

# Operating the System

## Perform Examination

---

### 4.4.7 Exposure



#### **WARNING!**

*Check that the settings of the SID (Source Image Distance) are accurate before the exposure.*

---



#### **WARNING!**

*Check that the selected workstation (wallstand, table) is connected and linked properly at the Examination Check screen of the image system before the exposure.*

---



#### **WARNING!**

*Check that the X-ray tube is set at correct position before the exposure.*

---

#### **CAUTION!**

*It is the responsibility of the user to ensure that the X-ray field is within the active detector area when exposing.*

---

#### **Note!**

*The operator is responsible for verifying the exposure parameters before exposure.*

---

Check that the examination conditions are displayed on the image system without failure.

Exposures are done using either the hand control or the prep. and X-ray buttons on the operator console.

Exposure operator console in

- A. normal position
- B. preparation position
- C. exposure position

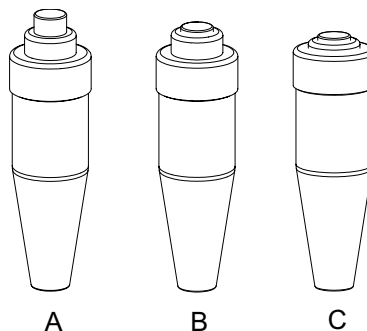

Fig. 4-18 Exposure operator console



# Operating the System

## Perform Examination

Exposure operator console:

- A. preparation exposure
- B. exposure position
- C. light indicating exposure

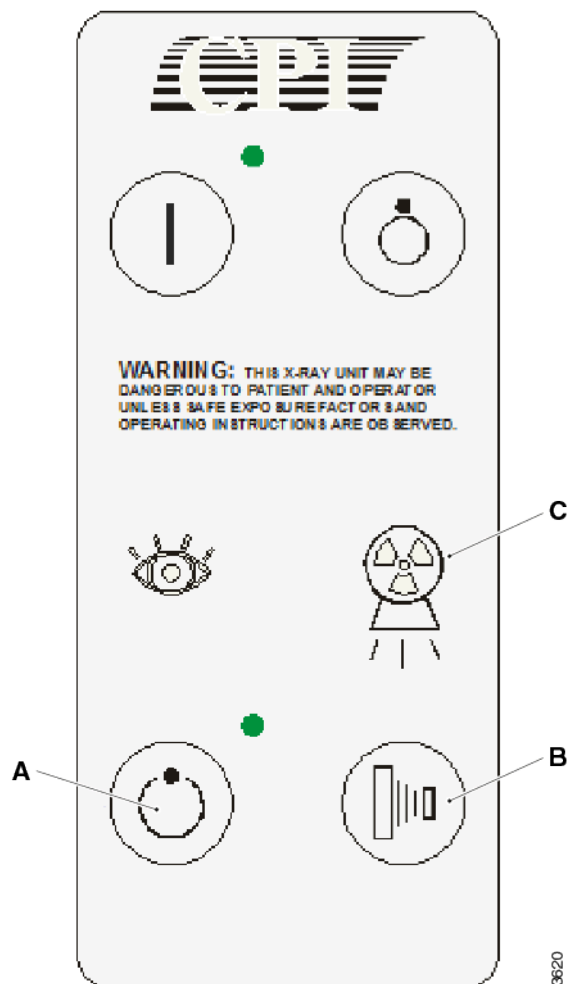

Fig. 4-19 Operator console

# Operating the System

## Perform Examination

### 4.4.8 Review Image

1. If the image is correct, select [End Exam] or continue examination if more images are planned.
2. If the image is not correct, select [Retake].
3. Type reject reason and retake image.

### 4.4.9 Change Workspace

1. Select [Protocol].

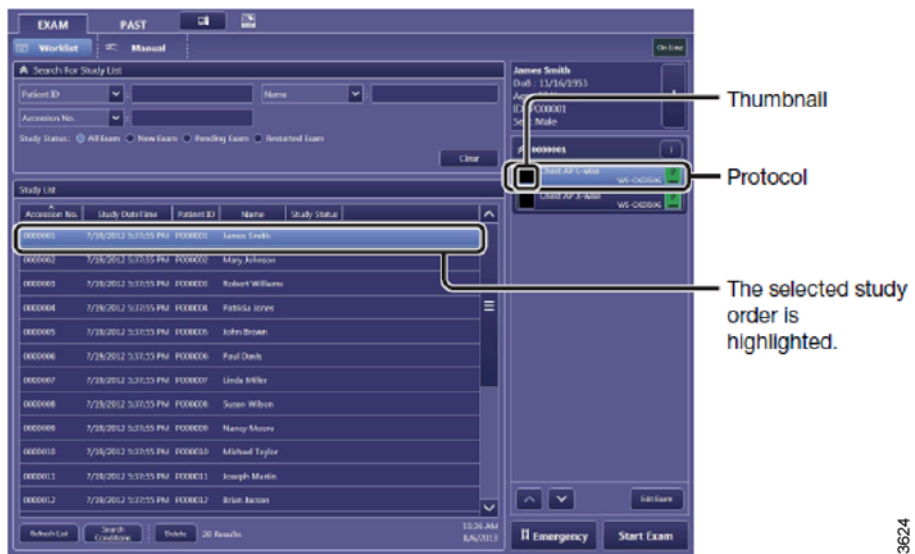

Fig. 4-20

2. Select detector or workspace.

9624

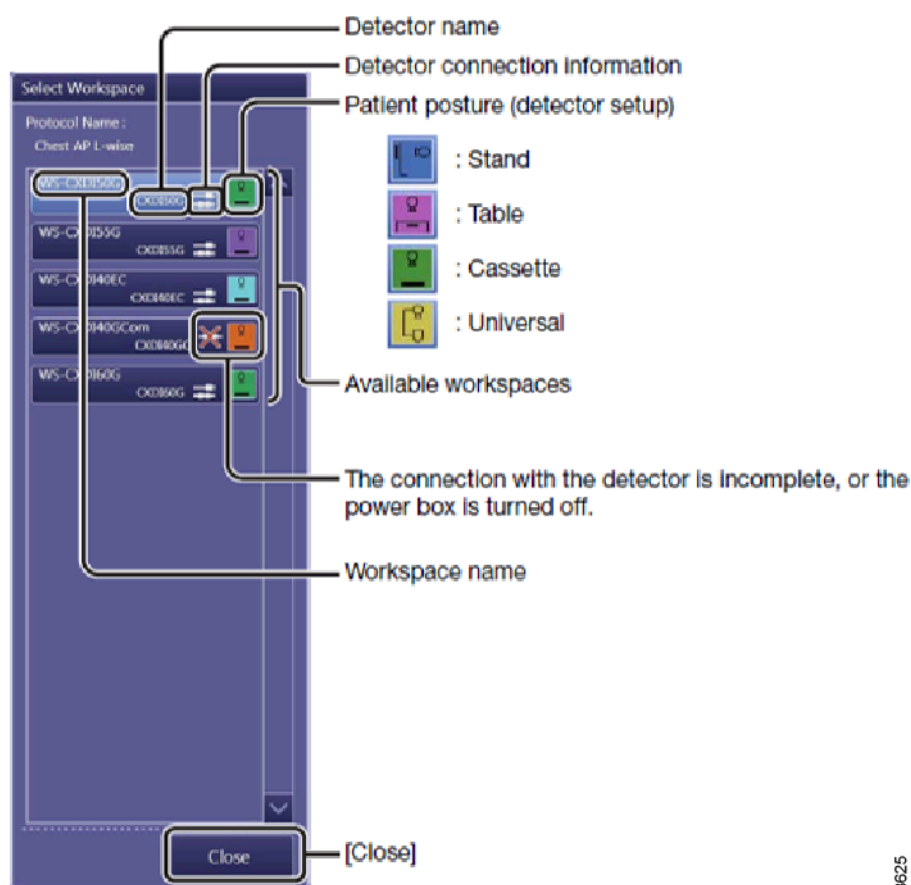

Fig. 4-21

3625

### 4.4.10 Basic Exposure Error Handling

Exposure not possible	Check	Measure
The small detector is selected (Green)	Is the small detector in the docking station?	Remove the small detector from the docking station.
Table examination (Pink)	If the table is equipped with a wireless detector and charging the detector in the holder - check if the connector is correctly connected to the detector.	Connect the connector correctly to the wireless detector.
Table examination	The detector is not in the table detector holder.	Place the detector in the table detector holder, make sure to connect the connector correctly.
Wallstand examination	The detector is not in the wallstand detector holder.	Place the detector in the wallstand detector holder, make sure to connect the connector correctly.

# Operating the System

## Emergency Patient

---

### 4.5 Emergency Patient

*Note!*

*Emergency patient can be used if it is necessary to begin acquiring images without knowing the patient information.*

*Main advantage is that it is possible to bind the images to a patient from the worklist.*

*Disadvantage is that all images within the emergency patient are collected in only one study.*

---

1. Select [Emergency] from the Exam screen.  
Patient name will be filled with Emergency (can be set in the service tool) and a unique patient ID.
2. Select the appropriate protocols and press [Start Exam].  
Predefined protocols will appear.
3. When finished acquiring images, pressing [End Exam] will display a "Data Binding" screen.

This screen has a worklist of all recent patients from the worklist server. From here it is possible to select a patient and bind this patient data to the recently acquired images.

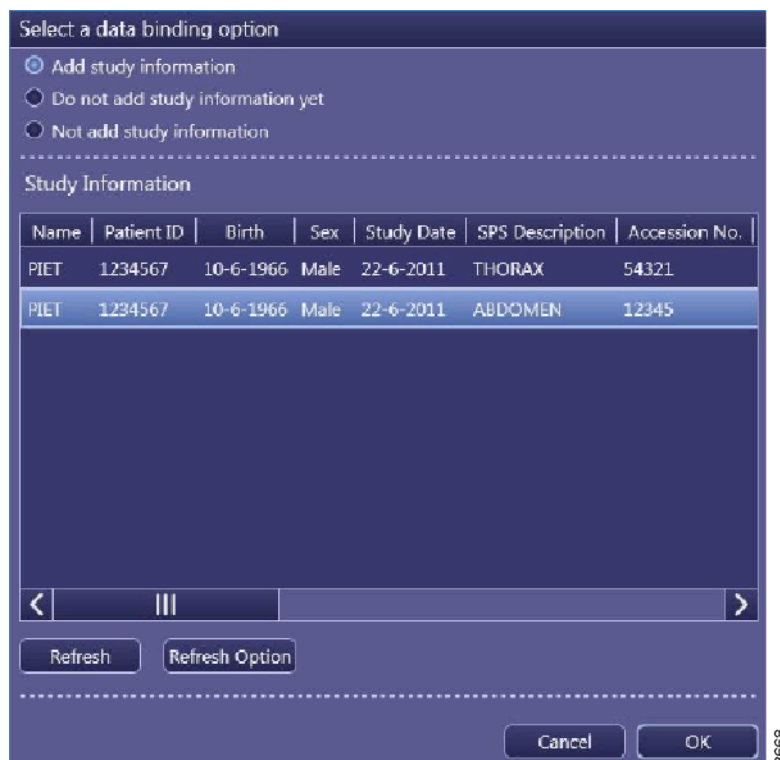

Fig. 4-22

*Note!*

*It is not possible to divide the images into several studies.*

*It is not possible to send images with [Send].*

---

### 4.6 Perform a Stitching Sequence

1. Select a stitching protocol.
2. Position the OTC centred to the detector in lateral direction.



Fig. 4-23

3. In vertical direction, the OTC shall preferably be positioned in the expected middle of the complete stitched image.  
The light field does not have to aim at the centre of the detector in the **vertical** direction.
4. Check the SID value on the collimator display and move the OTC to the correct position.  
Use the measuring tape integrated in the collimator to find the correct position.

# Operating the System

## Perform a Stitching Sequence

---



Fig. 4-24

5. Position a patient protection in front of the wallstand detector. The detector will move during the stitching sequence.  
The patient protection shall be positioned between the detector and the patient.
6. Confirm on the OTC display that the patient protection is in position.

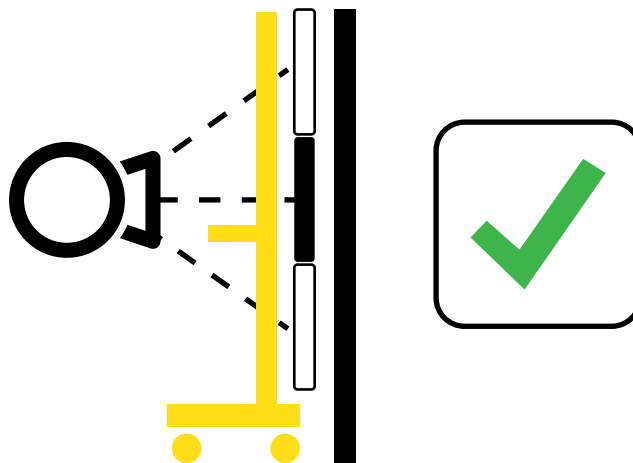

Fig. 4-25

7. Adjust the upper and lower collimator light limits to cover the area of interest.  
The upper and lower limit can be defined in either order; upper or lower first. The limits can also be redefined if needed.
8. The yellow LED on the OTC will flash until the correct position of the patient protection has been confirmed and the upper and lower limit have been defined by the user.  
When the yellow light is flashing it is not possible to perform an exposure. When the system is ready for the stitching sequence the yellow LED will turn to a fixed light.

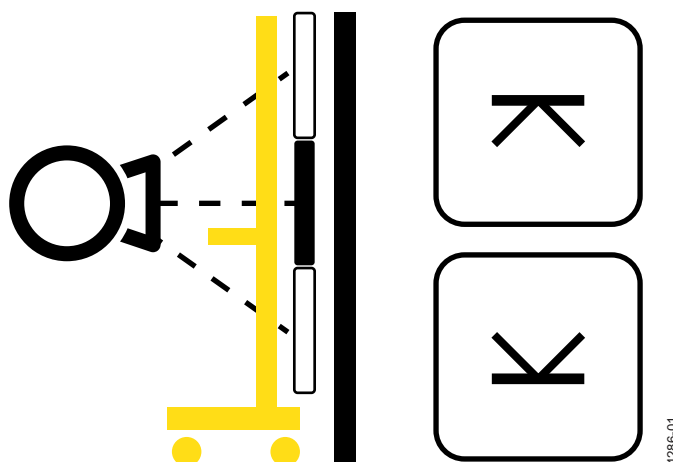

Fig. 4-26

- Switch on the collimator light.  
Check the upper collimator light border.  
Adjust the upper limit to cover the area of interest.  
Press the button for the upper limit on the OTC display. The button will then turn green.

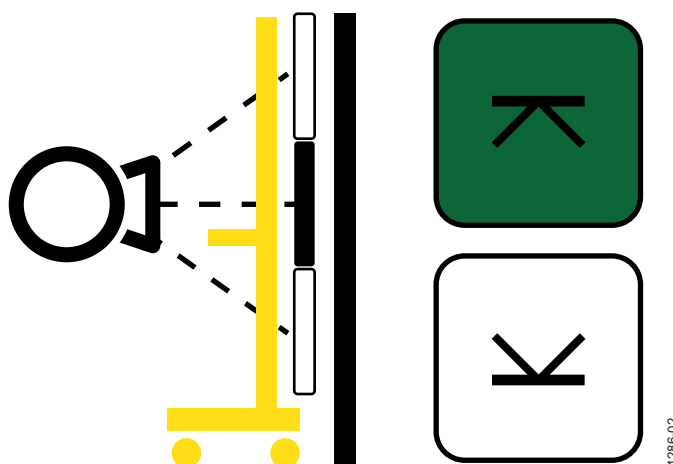

Fig. 4-27

- Switch on the collimator light.  
Check the lower collimator light border.  
Adjust the collimator knobs for the lower limit to cover the area of interest. The upper collimator light border will change when doing this adjustment but this will not affect the already defined upper limit. When the lower limit is accepted the button will turn green.

**Note!**

*The vertical position of the OTC must not be changed when one or both limits have been defined.*

If the vertical position is changed both upper and lower limits need to be redefined. The green indication on the buttons will be removed to indicate this.

Please note that if the selected limits cannot be accepted this will result in that the second limit cannot be defined (will not indicate green). There will be a beep and a note in the OTC display informing that stitching cannot be performed or that the limit is outside end stops (the detector cannot move to this position).

# Operating the System

## Perform a Stitching Sequence

---

*Note!*

*The alpha angle shall be + or – 90 degrees (depending on installation) for stitching sequence.*

*The alpha angle shall not be changed to define the upper and lower limits.*

---

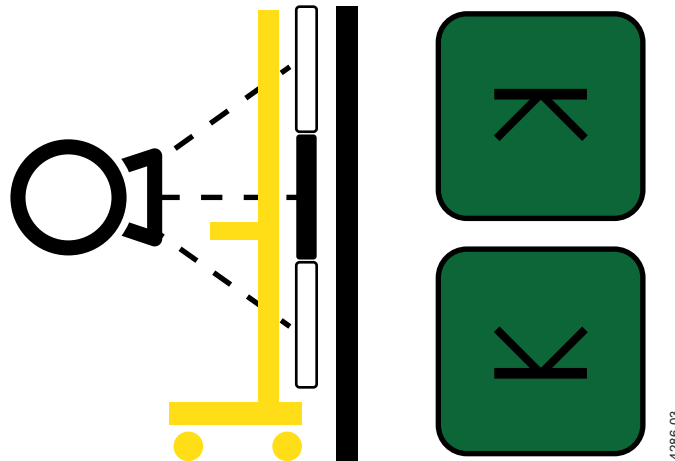

11. Adjust the width of the image if needed by using the collimator knobs.

The system is now ready for exposure.

On the OTC display you will get information about the total length of the image and number of images needed to cover the area of interest.

Inform the patient that the detector will move and to stand still during the complete sequence.

Press the exposure button and keep the button pressed until the last image is captured. If you release the button before the last image is captured you can press it again and the sequence will continue.

When the exposure handle is pressed the detector moves to the position for the upper image.

After the first exposure, the detector moves to the position for the next image. When the detector is ready, the exposure for the next image will be performed and so on for all included images.

When the last image included is captured the images can be stitched automatically in the Canon NE.



### 4.7 System Techniques

*Note!*

*The available techniques are depending on the actual configuration of the system.*

The available System Techniques are:

- *Free technique*
- *Table tracking*
- *Wallstand tracking*

Free technique is used for manual operation with a high level of freedom in positioning and exposure.

Table and Wall stand tracking techniques support by aligning the tube with the height of a vertical detector or maintaining a constant SID to a horizontal detector when the detector's position is adjusted, see **Fig. 4-28** below. Further details are described in following chapters.

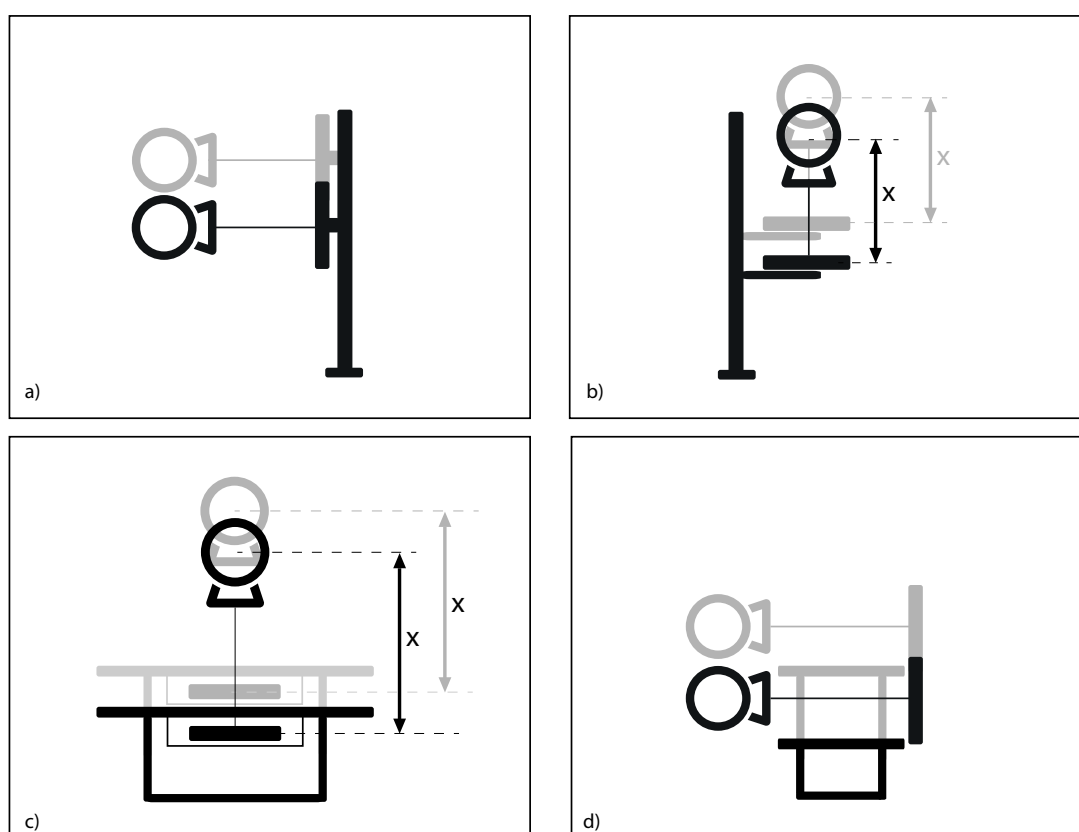

*Fig. 4-28 Wallstand tracking of vertical detector (a), and horizontal detector (b), and Table tracking of horizontal detector (c), and vertical detector (d).*

#### 4.7.1 Free Technique

The Free Technique is the standard mode with high level of freedom in positioning and exposure. When Free technique is activated the height to the floor, H, will be shown on the OTC display. Exposure is allowed when the OTC is not moving. Pay attention to selected workstation and position the OTC accordingly to align correctly with the detector. Selected workstation is shown by light indication on table or wall stand, see chapter 4.4.3, and with a corresponding icon on the OTC display, see chapter 3.2.3. The selected workstation is also shown in the Canon user interface.

# Operating the System

## System Techniques

---

### 4.7.2 Table Tracking

#### **CAUTION!**

---

**Always check if Auto Tracking is activated. Take extra care and monitor tube movements when Auto Tracking is active, ensuring there are no obstructions in its path. Active Auto Tracking is indicated by a tracking icon on the OTC display.**

---

#### **Note!**

---

*In table tracking technique, the exposure is blocked whenever a wallstand workstation is chosen.*

---

With Auto Tracking Table active the tube will track to keep the SID when the table top height is adjusted (above the safety height). With a vertical detector at the table top the tube will track the height of the detector/table (when above the safety height). The tube will automatically align and maintain the following Table positions, see **Fig. 4-28**:

- Table, horizontal detector (c): Keep SID.
- Table, vertical detector (d): Align with defined height.

The default SID / distances are set during installation of the system. The tube position can be changed when tracking is activated and the tube will then track based on the new position, for example a new SID.

Table **4-1** shows indication on the OTC display, safety zone restrictions and OTC position for tracking of vertical and horizontal detector at the Table.

Table 4-1 Table Tracking

<p>Auto tracking table is active when the table tracking icon is shown on the OTC display and the tube is aligned with detector height (vertical detector) or at the correct SID (horizontal detector). The light around the tube display will indicate green (fixed).</p> <div style="text-align: center;"> </div>	
<p>Tracking is possible when the lowest part of the overhead tube crane (OTC) is above the safety zone. When the OTC is inside the safety zone, tracking is not possible.</p> <div style="text-align: center;"> </div>	
<p>Vertical detector</p>	<p>Horizontal detector</p>
<div style="text-align: center;"> </div> <p>Tracking operation is only performed when the alpha angle of the tube is between +46 and +134 degrees and between 46 and 134 degrees.</p> <div style="text-align: center;"> </div>	<div style="text-align: center;"> </div> <p>Tracking operation is only performed when the alpha angle of the tube is between +45 and -45 degrees.</p> <div style="text-align: center;"> </div>

# Operating the System

## System Techniques

---

### 4.7.3 Auto Tracking, Wallstand

#### **CAUTION!**

---

**Always check if Auto Tracking is activated. Take extra care and monitor tube movements when Auto Tracking is active, ensuring there are no obstructions in its path. Active Auto Tracking is indicated by a tracking icon on the OTC display and a steady light on the synchronization button at the Wallstand.**

---

#### **Note!**

---

*In Wallstand tracking technique, the exposure is blocked whenever a table workstation is chosen.*

---

With Auto Tracking Wallstand active the tube will track to keep aligned with the Wallstand detector height when the height of the Wallstand detector is changed. If the Wallstand detector is tilted the tube can be rotated and track to keep the SID when the height of the horizontal detector is changed.

The tube will automatically align and maintain the following Wall stand positions, see **Fig. 4-28**:

- Wall stand, vertical detector (a): Align with detector height.
- Wall stand, horizontal detector (b): Keep SID.

The default SID / distances are set during installation of the system. The tube position can be changed when tracking is activated and the tube will then track based on the new position, see **Fig. 4-29** below for examples where the tube is tilted (e), and off-centered (f).

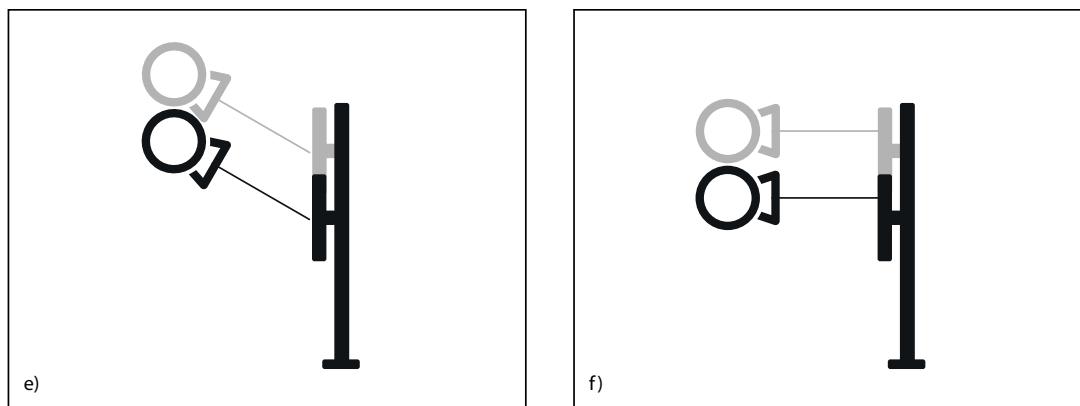

Fig. 4-29

Active Auto tracking is indicated by Tracking icon on the OTC display, see **Fig. 4-30**, and by the light indication on synchronization button at the Wall stand. The blue arrow will be visible until the OTC is aligned. There will also be a sound signal indication that correct position is reached.

When Automatic tracking Wall stand is activated and the OTC aligned the OTC will track the position of the detector when the position of the detector is changed. If the position of the detector has changed and the OTC did not reach the final aligned position this will be indicated by the light indication on the synchronization button. The synchronization button can then be pushed to align the OTC.

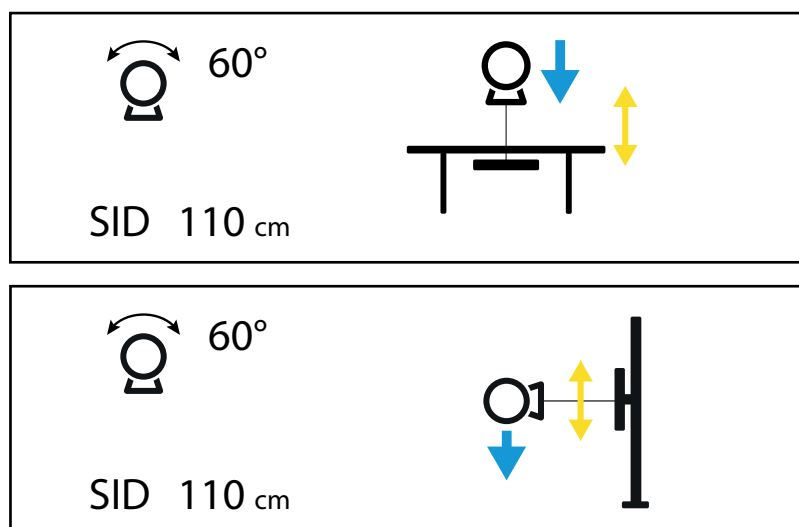

Fig. 4-30

Table **4-2** shows indication on the OTC display and OTC position for tracking of vertical and horizontal detector at the Wallstand detector.

# Operating the System

## System Techniques

Table 4-2 Wallstand tracking

<p>Auto tracking wallstand is active when the wallstand tracking icon is shown on the OTC display and the tube is aligned with detector height (vertical detector) or at the correct SID (horizontal detector). The light around the tube display will indicate green (fixed) and the led at the wallstand console has a fixed light.</p>	
<p>Vertical detector</p>	<p>Horizontal detector</p>
<p>Tracking operation is only performed when the alpha angle of the tube is between +46 and +134 degrees and between 46 and 134 degrees.</p>	<p>Tracking operation is only performed when the alpha angle of the tube is between +45 and -45 degrees.</p>

## 4.8 Operating the Table

### 4.8.1 General



#### **WARNING!**

---

***Risk of squeezing.***

***Keep the area under the table free from obstacles during motorized movements.***

---

#### **CAUTION!**

---

***When the table is switched off, wait at least 15 seconds before switching it on again.***

---

#### **Note!**

---

*The system shall only be operated by trained radiologist, service technicians or product specialists.*

---

### 4.8.2 Functional Description, Closed Table 0181

The control of the table is positioned on the lower part of the vertical lift as a kick box or on the floor as a foot control, there is an optional hand control. The controls are used for enabling and disabling of functions of the table. These functions are described below.

#### 4.8.2.1 Movements

The table can be moved in Z-direction for up and down movements and in X- and Y-direction for longitudinal and lateral movements. See figure below for different controllers.

# Operating the System

## Operating the Table

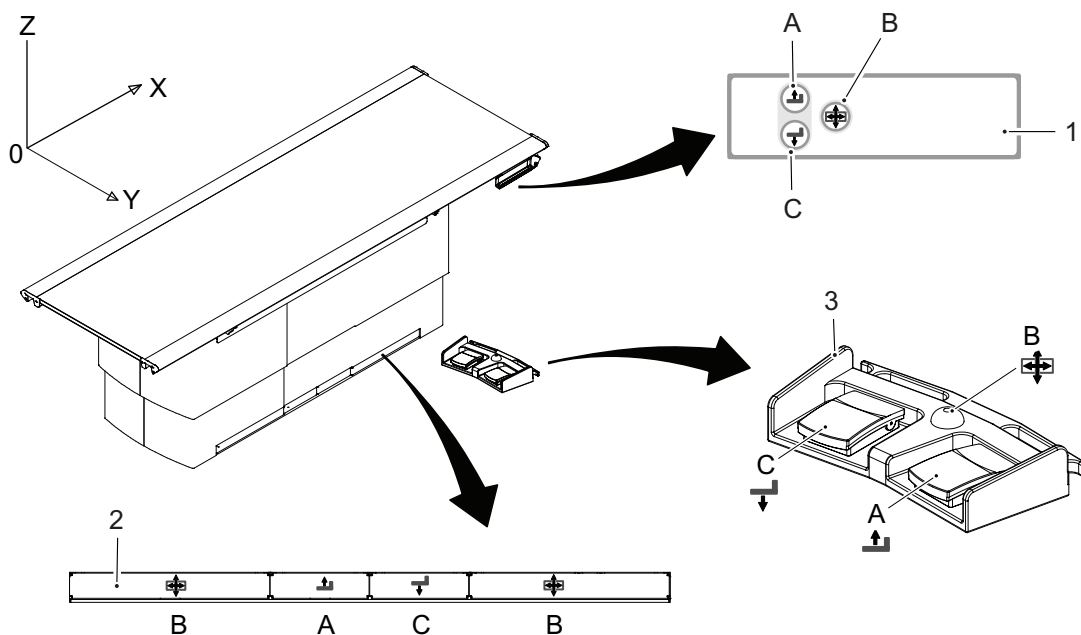

Fig. 4-31 Table controls

1. Maneuver hand control (optional)
2. Kick box control
3. Foot control

Table 4-3

Pos.	Direction	Movement	Activation
A	Z up	Motorized	Press and hold the button to activate the movement. Release the button to stop the movement.
C	Z down		
B	X and Y Lateral and longitudinal	Manual	Press and hold the button to release the brake and to be able to move the table top. Release the button to activate the brake and the table top will be locked.

### CAUTION!

- **When moving the table with the patient or devices nearby, be careful so the table does not come in contact with the patient and devices.**
- **When lowering the table, be careful so the patient does not carelessly come in contact with the table.**
- **When moving the table or the table top, be careful not to get your arms and fingers caught in the device.**
- **When moving the table by foot control or maneuver handle, be careful not to get your arms and fingers caught between the table and surrounding objects.**



**CAUTION!**

**Make sure no foot control, maneuver handle or kick box control is pressed during power up.**

**An activated control during power up will set the table in an error state and disable its use**

---

**Moving the Table Top**

To manually move the table top, release the brakes and use the hand grip rails located at the long sides of the table top.

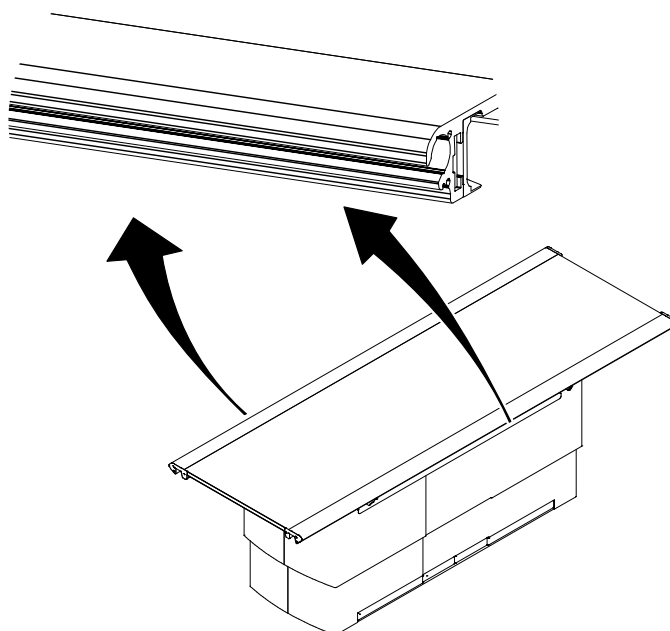

*Fig. 4-32 Manual movement of table top*

# Operating the System

## Operating the Table

---

### 4.8.3 Detector, Table

#### 4.8.3.1 Load the Detector

The instruction describes 14x17 and 17x17 detector.

The figures show 14x17 detector.

**CAUTION!** \_\_\_\_\_

**Do not put any load on the detector tray. It might be damaged.**

---

**CAUTION!** \_\_\_\_\_

**Always supervise movements of the detector to avoid collision with peripherals.**

---

**Note!** \_\_\_\_\_

*This instruction only applies to the portable detector.*

---

1. Press the detector tray button and pull out the detector tray until it locks.

**Note!** \_\_\_\_\_

*The detector tray should be in locked position.*

---

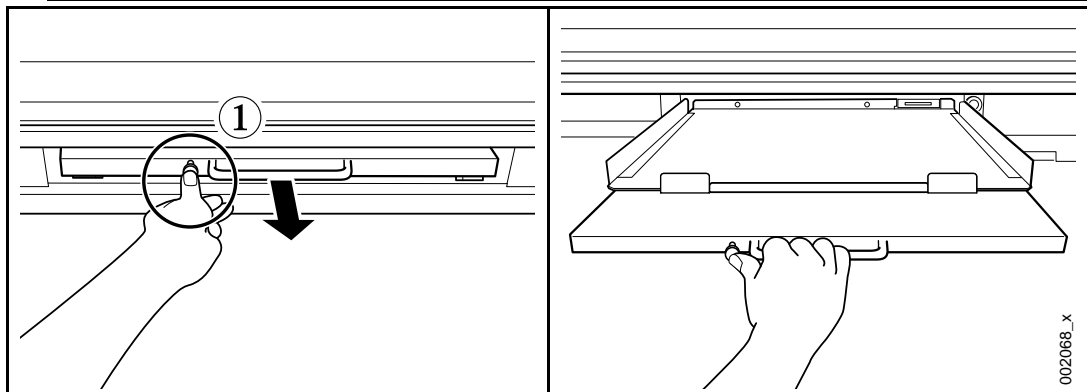

# Operating the System

## Operating the Table

2. Insert the detector into the tray.

**Note!**

*It is important to check that the detector is correctly inserted into the detector tray. An incorrect positioning will result in incomplete images.*

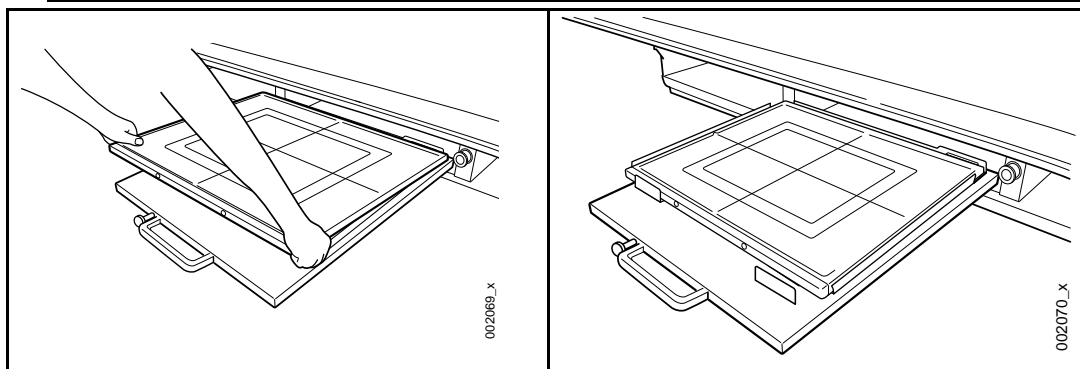

3. Press the button of the detector tray and push in the detector tray into the detector holder.

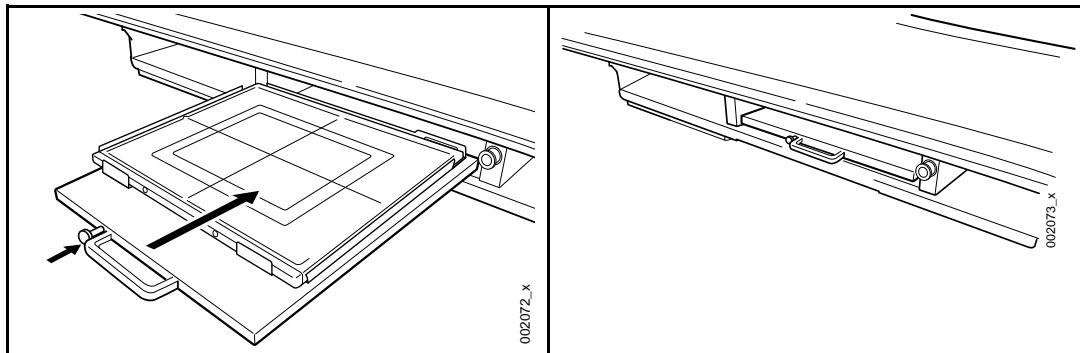

# Operating the System

## Operating the Table

### 4.8.3.2 Rotate the 14x17 Detector

Changes between portrait and landscape.

1. Press the detector tray button and pull out the detector tray until it locks.

*Note!*

*The detector tray should be in locked position.*

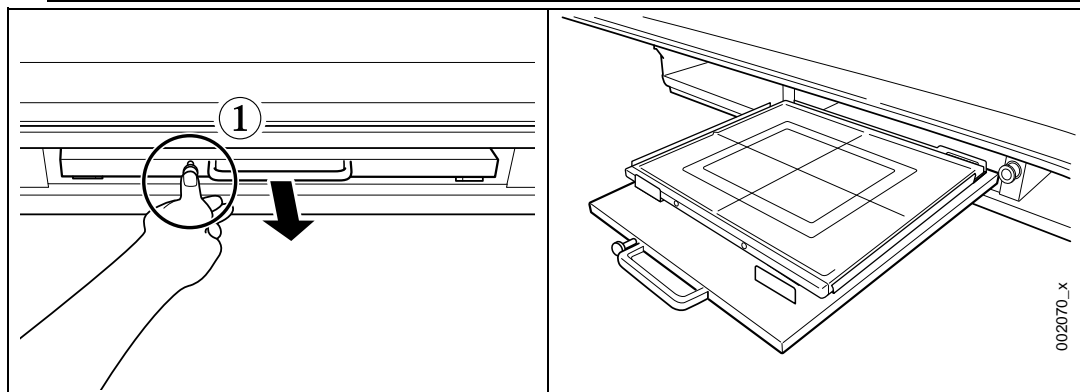

2. Rotate the detector 90°.

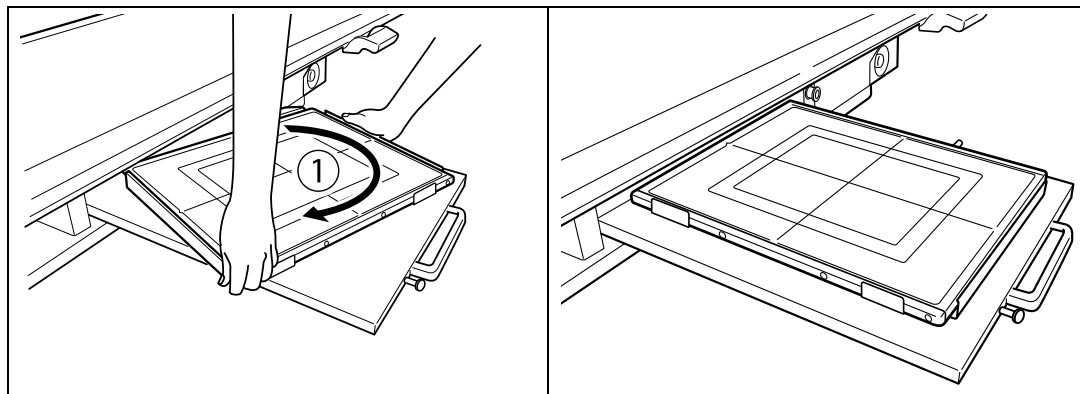

3. Press the button of the detector tray and push in the detector tray into the detector holder.

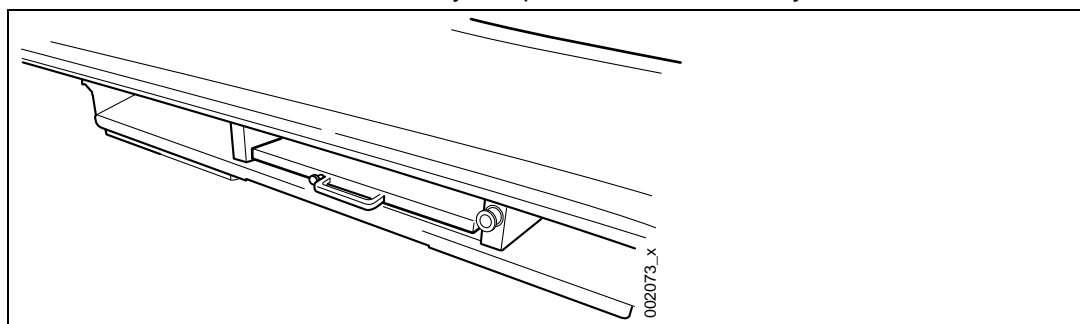

### 4.8.3.3 Remove the Detector

The instruction describes 14x17 and 17x17 detector.

The figures show 14x17 detector.

1. Press the detector tray button and pull out the detector tray until it locks.

**Note!**

*The detector tray should be in locked position.*

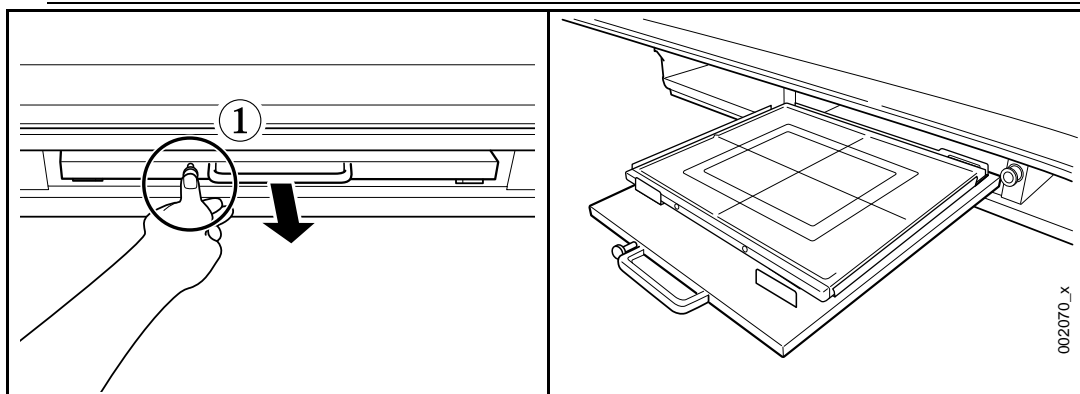

2. Remove the detector, lift and pull the detector towards you.

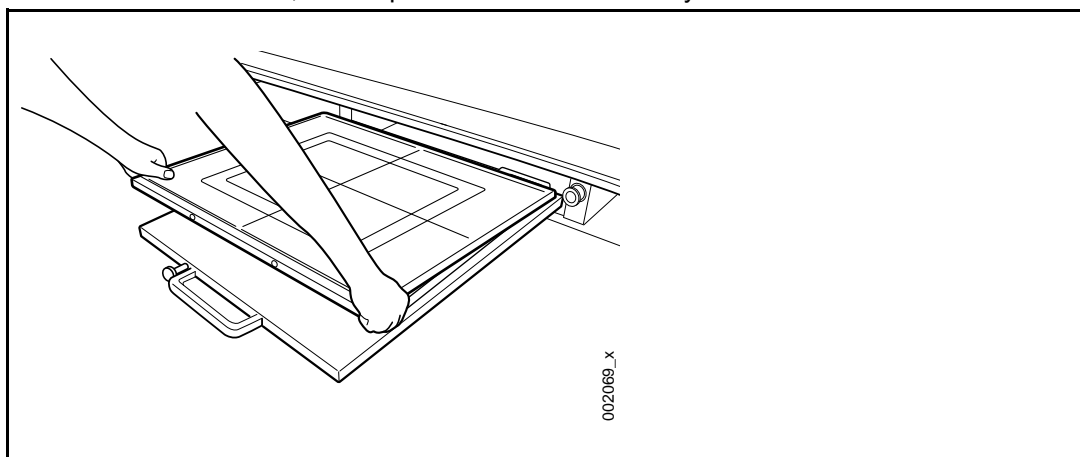

# Operating the System

## Operating the Table

---

### 4.8.4 Grid, Table

#### 4.8.4.1 Remove Grid

1. Pull out the grid.

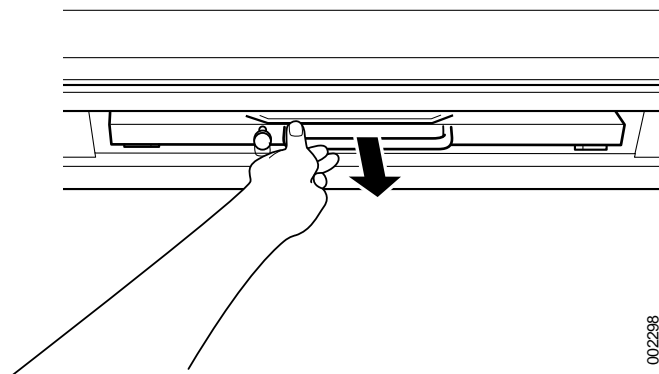

Fig. 4-33

002298

### 4.8.4.2 Insert Grid



#### **WARNING!**

---

*Failure to insert the grid in the correct orientation, with the tube side facing towards the X-ray source, can result in unsuccessful patient imaging.*

*Additional corrective patient imaging and additional ionising radiation exposure for the patient may be needed.*

*Ensure the grid is inserted in the correct way.*

---

#### **CAUTION!**

---

*Use the grid that is appropriate for exposure conditions (focus distance, etc.)*

---

Hold the grid in both hands holding the metal on the sides of the grid, and insert the grid along the grid holder rail on the top of the detector tray.

#### **CAUTION!**

---

*Properly insert the grid along with the rail. The device may be damaged if not mounted properly.*

---

#### **Note!**

---

*When mounting the grid, after confirming that right side is up, check to make sure that it is mounted correctly with the top surface towards you.*

*The top surface is the one with the sticker affixed to the metal handle of the grid surface.*

---

1. Insert the grid with the tube side facing upwards, towards the X-ray source. The tube side of the grid has the specification label and the grid centre line identification.
2. Push in the grid, until it clicks.

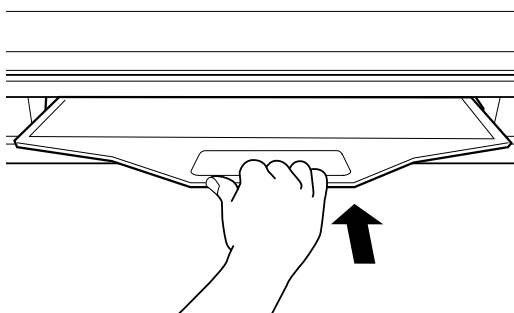

Fig. 4-34

# Operating the System

## Operating the Table

### 4.8.5 Attach/Remove Accessories

Accessories are attached and removed as shown in the figures below. This instruction is valid for all accessories attached to the table top.

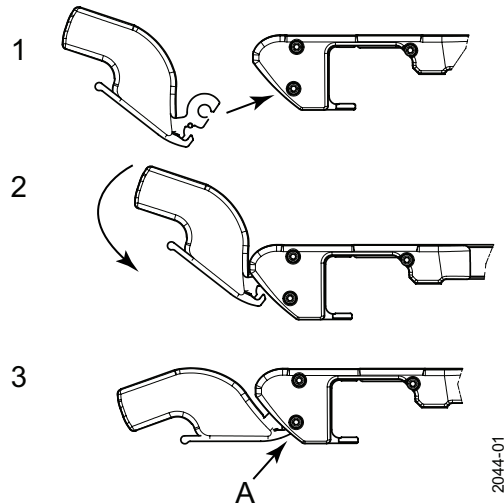

- To attach:
  1. Insert the accessory.
  2. Rotate it downwards.
  3. Click to attach at **A**.

Fig. 4-35 Attach accessories

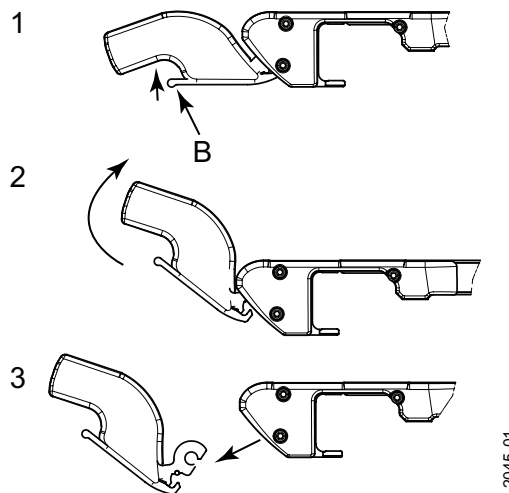

- To remove:
  1. Press on the accessory at **B**.
  2. Rotate it upward.
  3. Remove the accessory.

Fig. 4-36 Remove accessories



### 4.9 Operating the Wallstand

#### 4.9.1 General



#### **WARNING!**

---

*If any item is removed from the wallstand, e.g. the detector or lateral armrest, the wallstand will become unbalanced.*

*When the brake is released, part of the wallstand will move upward and can cause injury.*

*The operation should be performed by trained personnel.*

---

#### **CAUTION!**

---

*Do not place the device where dust may cause malfunction to the power source.*

---

#### **CAUTION!**

---

*To avoid any injuries to patient, user or system, peripherals should always be placed outside the working area.*

---

#### **CAUTION!**

---

*Do not to load more than 25 kg on the lateral armrest.*

---

#### **CAUTION!**

---

*The patient must be supported by trained radiologist when using the lateral armrest.*

---

#### **CAUTION!**

---

*Do not use the lateral armrest when it is unlocked.*

---

# Operating the System

## Operating the Wallstand

---

### 4.9.2 Functional Description

The control of the wallstand is positioned on the detector holder wagon, there is an optional foot control. The controls are used for enabling and disabling functions concerning the wallstand. These functions are described below.

#### 4.9.2.1 Movements



#### **WARNING!**

---

*If any item is removed from the wallstand, e.g. the detector or lateral armrest, the wallstand will become unbalanced.*

*When the brake is released, part of the wallstand will move upward and can cause injury.*

*The operation should be performed by trained personnel.*

---



#### **WARNING!**

---

*Hazardous situations when moving the tilted detector holder in Z-direction to the floor:*

- *Detector collision with the floor*
  - *Squeezing hazard for patient*
- 

#### **CAUTION!**

---

*Before raising or lowering the detector holder, be sure to check the position of the patient.*

*When raising or lowering the device with the patient nearby, be careful so the device does not come in contact with the patient.*

*Make sure that the patient is not leaning on and putting a load on the patient support grip when raising or lowering the grip.*

---

# Operating the System

## Operating the Wallstand

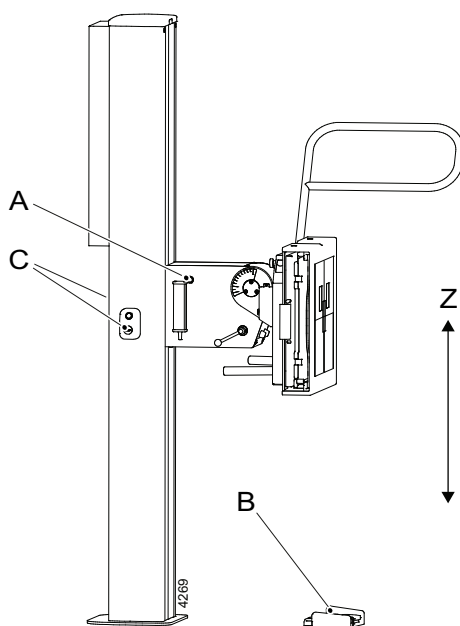

The wallstand can be moved manually in Z-direction for movements upward and downward. A button (A) for brake release is positioned on the left and right sides of the detector holder wagon. An optional button for brake release is positioned on the foot control.

Press and hold the button (A or B) to release the brake and push the wagon up or down.

Release the button (A or B) when the detector holder is in position to activate and lock the brake.

Fig. 4-37

A Control for Z brake release

B Foot control (option)

# Operating the System

## Operating the Wallstand

---

### 4.9.2.2 Motorized Z-movement (Option)

The controls concerning the motorized wallstand in Z-direction are positioned on the imaging unit holder bracket and at the foot of the column.

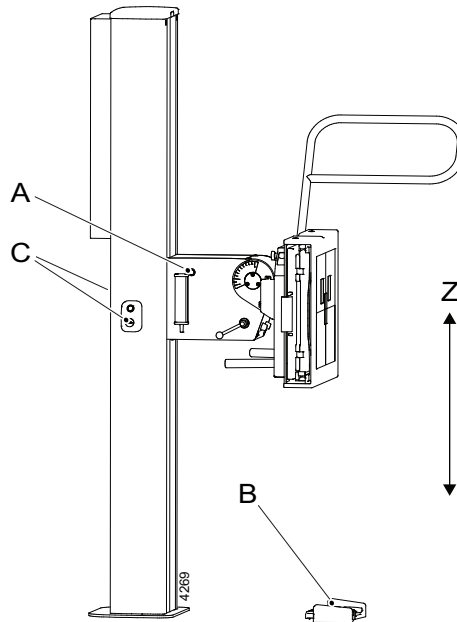

Fig. 4-38 Motorized Z-movement controls

- A Release/engage imaging unit brake, standard
- B Release/engage imaging unit brake, option
- C Emergency STOP

The imaging unit brake key (B) automatically lights the collimator lamp on activation, if wall tracking is selected and detector is moved. The collimator is automatically switched off after a pre-defined time when the imaging unit brake key has been deactivated (released).

The imaging unit brake key (B), generally named movement key, is also used for enabling movement of the OTC (Z-direction).

On activation of the imaging unit brake key, an automatic movement of OTC is allowed. The automatic movement is used for tracking the movement of the detector and to synchronize (align) the x-ray tube and the imaging unit.

### 4.9.2.3 Patient Support Grip (Option)

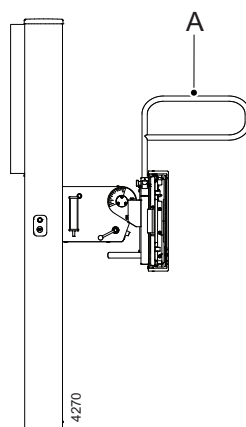

Fig. 4-39

A Patient Support Grip

### 4.9.2.4 Detector, Detector Holder and Grid (Option)

#### Tiltable Detector Holder

The wallstand has an optional tiltable detector holder wagon. The wagon can make it possible to tilt the detector holder from  $0^\circ$  +  $90^\circ$ . See index positions in the figure below

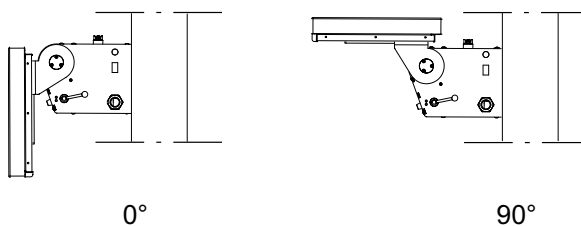

Fig. 4-40 Index positions

#### Tilt Detector Holder

Turn the handle (1) up to unlock the tiltable detector holder according to picture B in figure below. Push the detector holder up in right position and then turn the handle down to lock the holder, see picture C in the figure below.

# Operating the System

## Operating the Wallstand

---

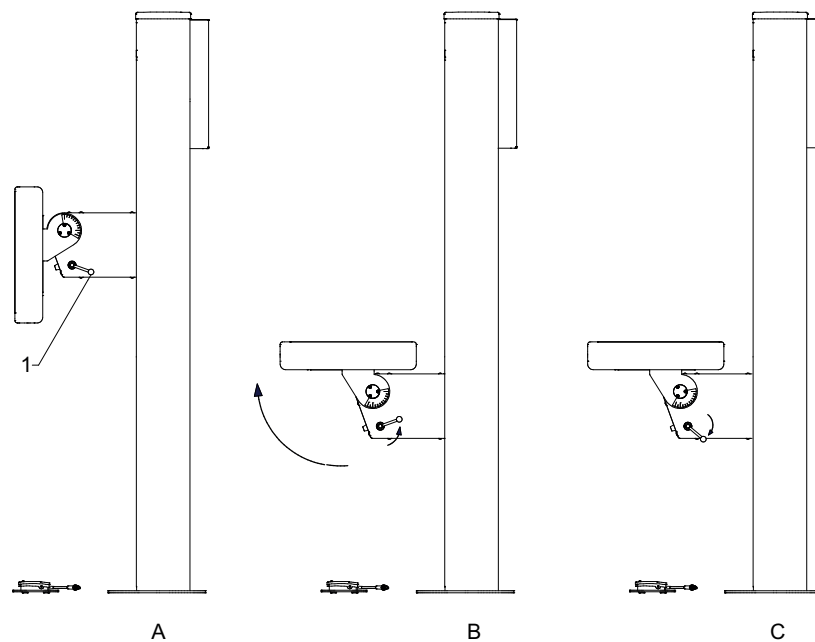

Fig. 4-41 Tilting detector holder

### Start Position of the Handle

#### **CAUTION!**

---

#### **Squeezing hazards:**

**between the detector holder and other parts or devices when adjusting the angle of the detector holder.**

**for fingers when operating the detector.**

**for arm and fingers when operating the detector holder**

---

To position the handle (See pos.1 in **Fig. 4-41**, in its start position);

1. Drag the handle out from the wagon.
2. Turn the handle to the right position.
3. Push the handle back toward the wagon.

### 4.9.3 Detector, Wallstand



#### **WARNING!**

---

**If any item is removed from the wallstand, e.g. the detector or lateral armrest, the wallstand will become unbalanced.**

**When the brake is released, part of the wallstand will move upward and can cause injury.**

**The operation should be performed by trained personnel.**

---



### **WARNING!**

**Complete the setting of the counterweights before setting or adjusting of detector and other equipment.**

---

### **Note!**

*The system shall only be operated by trained radiologist, service technicians or product specialists.*

---



### **WARNING!**

**Shutdown the power when replacing a fixed detector.  
Confirm that the wallstand is not possible to elevate.**

---

### **CAUTION!**

**Do not put any load on the detector tray. It might be damaged.**

---

### **CAUTION!**

**Always supervise movements of the detector to avoid collision with peripherals.**

---

### **Note!**

*This instruction only applies to the portable image receptor.*

---

### **Note!**

*The detector tray, buttons, and latches are located in different positions for a left and a right operated wallstand.*

---

### **Note!**

*If the system includes more than one detector, assure that the currently active detector is used.*

---

#### **4.9.3.1 Load the Detector**

The instruction describes 14x17 and 17x17 detector operated from the right side.

The figures show 14x17 detector.

# Operating the System

## Operating the Wallstand

---



### **WARNING!**

---

*If any item is removed from the wallstand, e.g. the detector or lateral armrest, the wallstand will become unbalanced.*

*When the brake is released, part of the wallstand will move upward and can cause injury.*

*The operation should be performed by trained personnel.*

---



### **WARNING!**

---

*Always turn off the power and lock the main switch before service or maintenance.*

---



### **WARNING!**

---

*Complete the setting of the counterweights before setting or adjusting of detector and other equipment.*

---

### **Note!**

---

*Depending on left or right operated wallstand, the location of the detector tray and position of button and latches is different.*

---



# Operating the System

## Operating the Wallstand

---

1. Press the detector tray button and pull out the detector tray until it locks.

**Note!**

*The detector tray should be in locked position.*

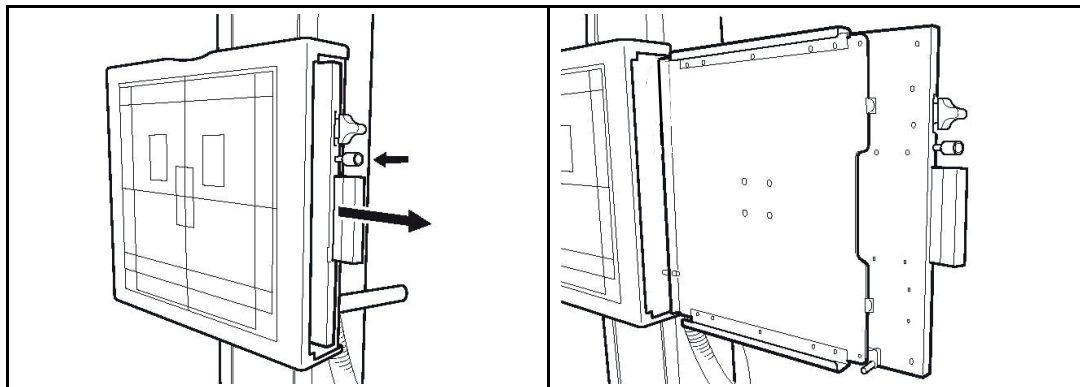

2. Press down the latch and insert the detector into the detector tray until the latch locks.

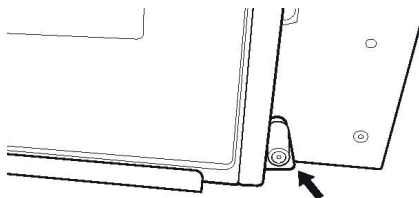
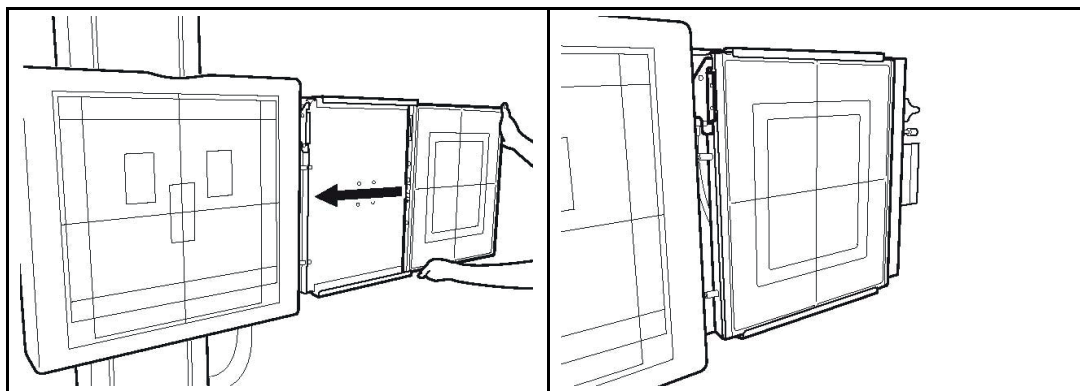

Fig. 4-42 Latch, detector tray



**CAUTION!**

**Confirm that the latch locks.**

---

# Operating the System

## Operating the Wallstand

---

3. Press the button of the detector tray and push the detector tray into the detector holder.

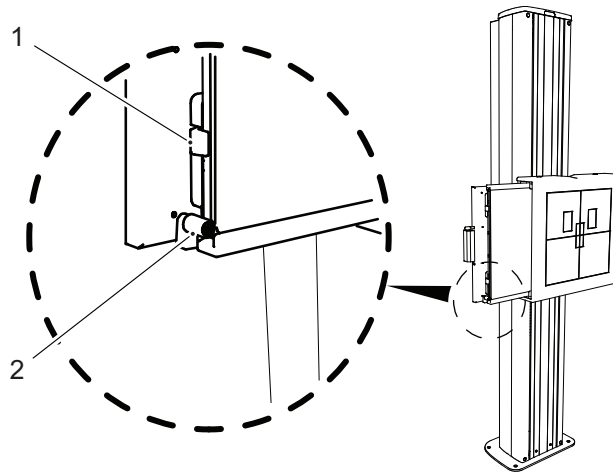
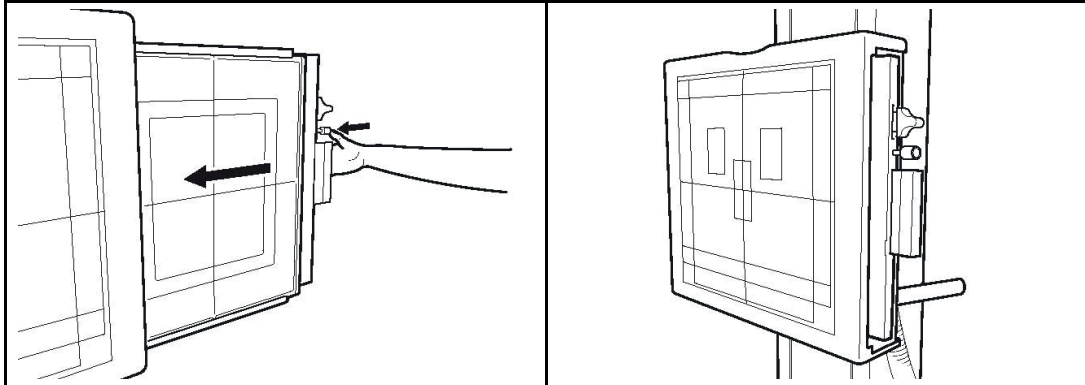

Fig. 4-43

4. Push the detector until the hooks (1) and the latch (2) lock.  
Chargeable detectors will start charging when set in this position.

**CAUTION!**

**If the detector or the detector holder are not properly inserted, a warning symbol is shown on the display.**

**Wrong position of the detector or the detector holder leads to incorrect images.**

---

### 4.9.3.2 Rotate the 14x17 Detector

Changes between portrait and landscape.

1. Press the detector tray button and pull out the detector tray until it locks.

**Note!**

*The detector tray should be in locked position.*

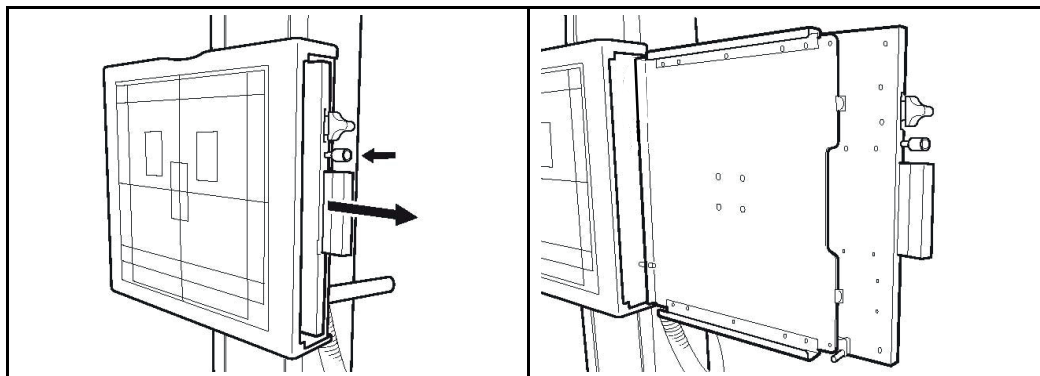

2. Hold the lower side of the detector, press up or down the latch (1) and rotate the detector 90° (2).

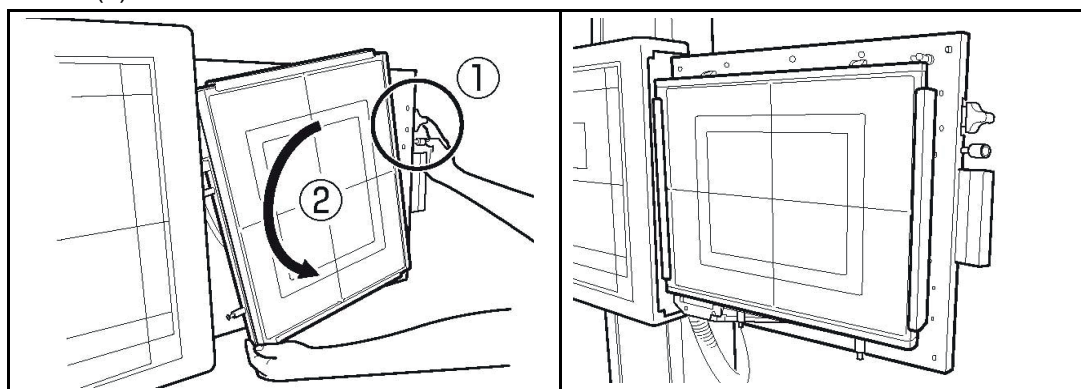

- To set the detector, pull the latch
  - upward at upper position of the tray.
  - downward at the center of the tray.

**Note!**

*Depending on left or right operated wallstand, the location of the detector tray and position of button and latches is different.*

# Operating the System

## Operating the Wallstand

---

### 4.9.3.3 Remove the Detector

The instruction describes 14x17 and 17x17 detector operated from the right side.

The figures shows 14x17 detector.

1. Press the detector tray button and pull out the detector tray until it locks.

**Note!** \_\_\_\_\_

*The detector tray should be in locked position.*

---

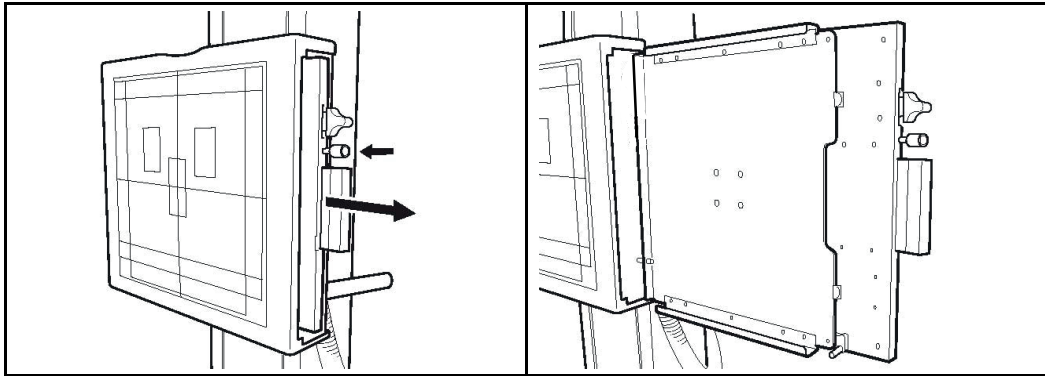

2. Press down the latch and remove the detector.

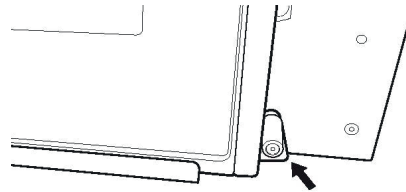

*Fig. 4-44 Latch, detector tray*

**Note!** \_\_\_\_\_

*Depending on left or right operated wallstand, the location of the detector tray and position of button and latches is different.*

---

### 4.9.3.4 Grid, Wallstand

#### Remove Grid

1. Pull the grid in the direction of the arrow.  
Hold the metallic handle on the side of the grid.

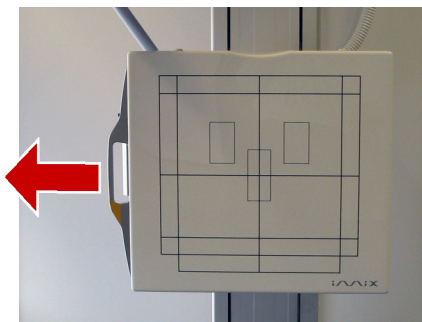

Fig. 4-45

#### Insert Grid

#### **CAUTION!**

- Use the grid that is appropriate for exposure conditions (distance, etc).
- 

#### **CAUTION!**

**Insert the grid along with the rail.**

**The device may be damaged if not mounted in properly.**

---

#### **Note!**

*The grid should be inserted with the top surface towards you.*

*The top surface has the sticker affixed to the metal handle of the grid surface.*

---

1. Hold the grid in both hands, grip on the metal on the sides of the grid.
2. Insert the grid along the grid holder rail on the top of the detector tray.  
Press in the grid until a click sounds. The grid is now properly in position.

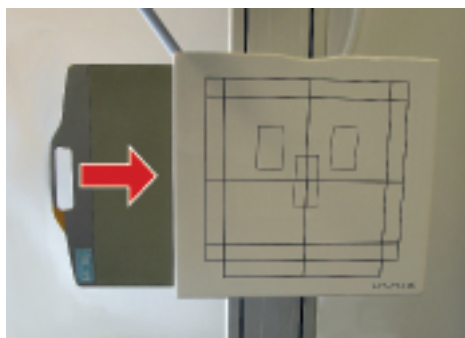

Fig. 4-46

# Operating the System

## Super User

### 4.10 Super User

#### 4.10.1 Change Exposure Parameters

1. Select [System setup] and [Protocol Editor].

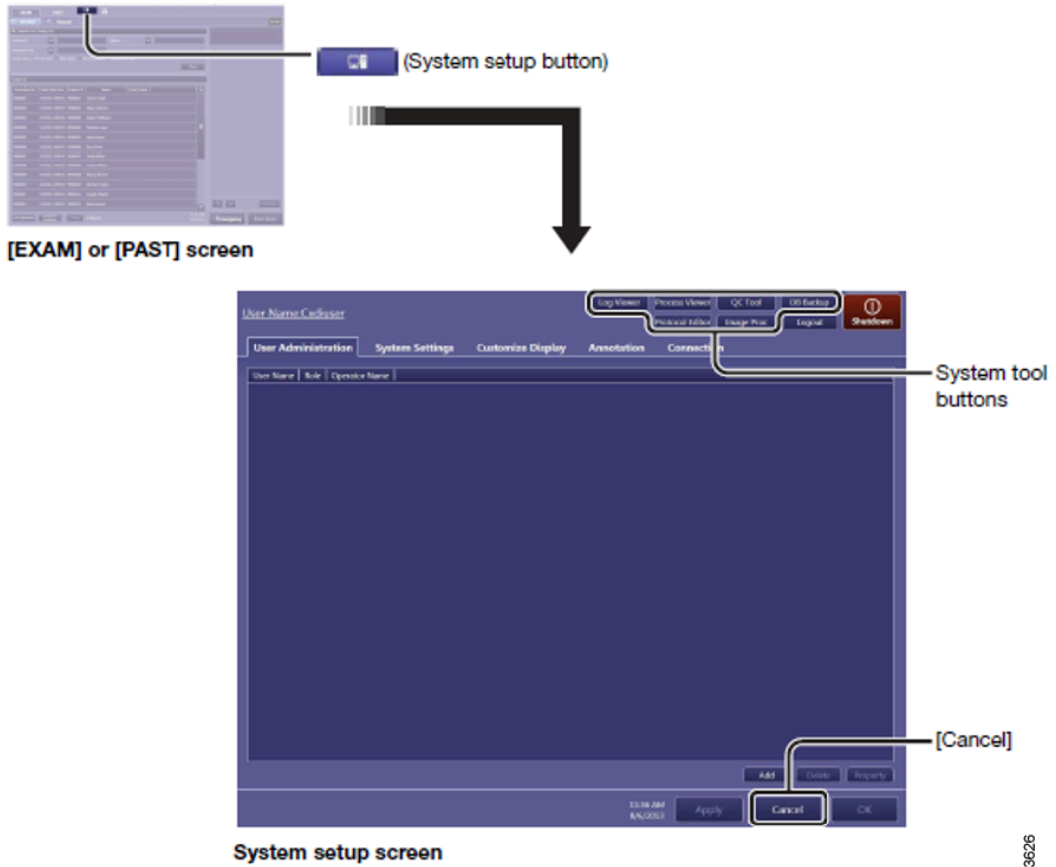

Fig. 4-47

9626

2. Select protocol.

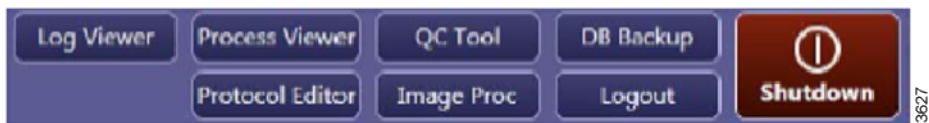

Fig. 4-48

- Protocol Name [Edit]:  
Select exposure parameters, autoposition or alpha angle
- Workspace [Edit]  
Select to change default workspace.

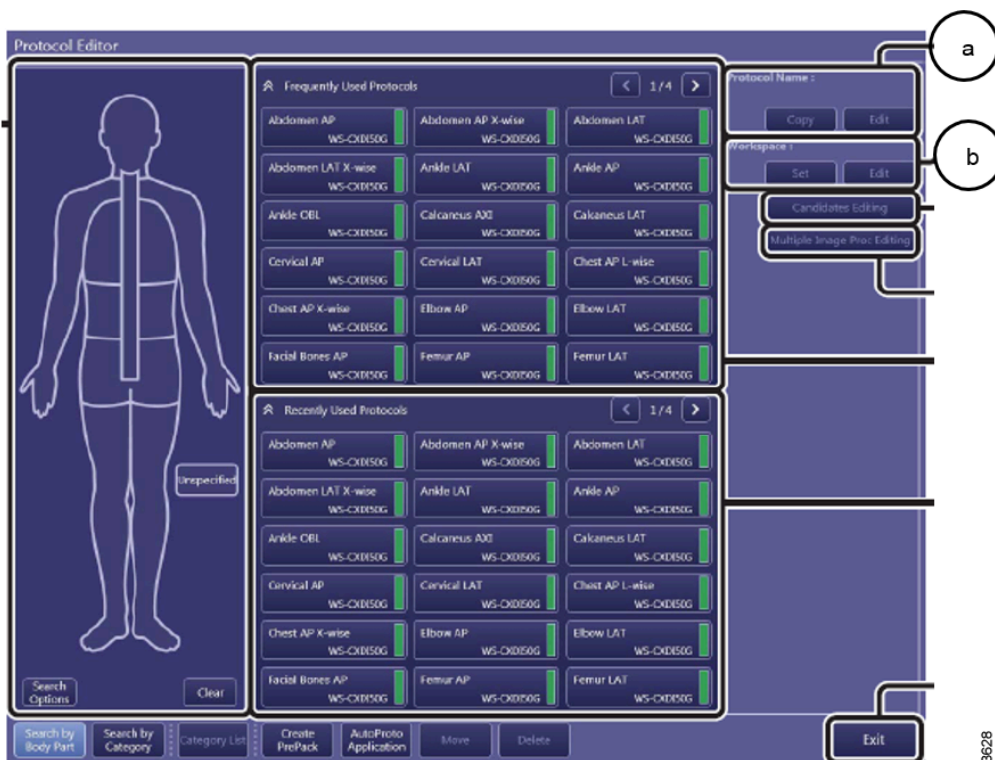

Fig. 4-49

# Operating the System

## Super User

- c Select [Edit] under [Protocol Name]. Change default workspace if necessary. The user can change this during examination.

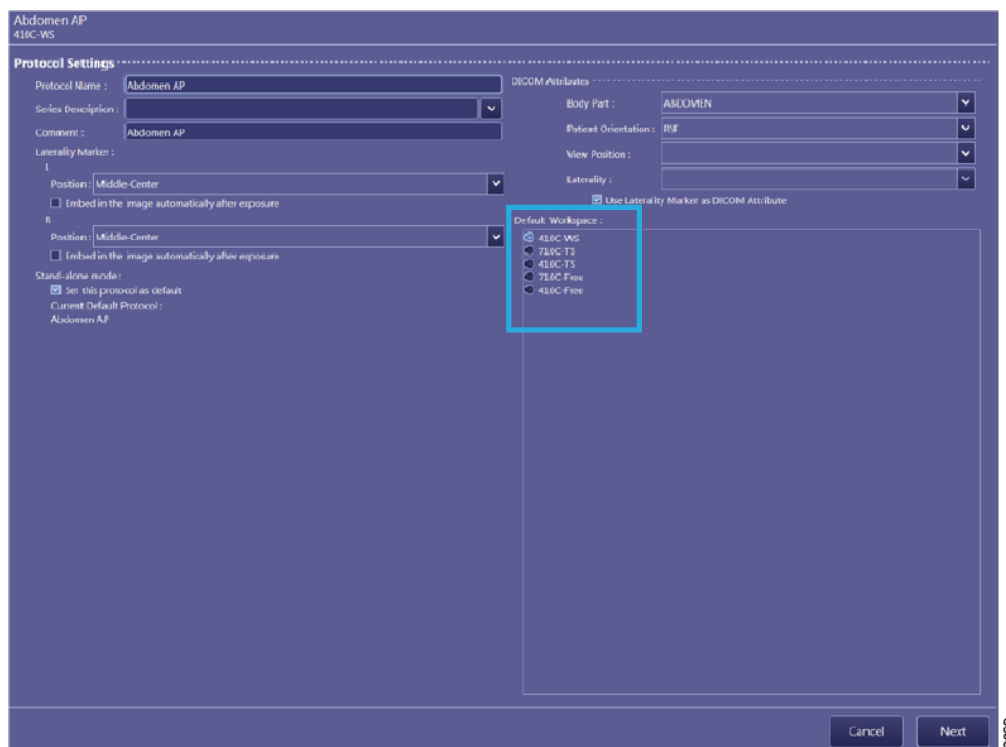

Fig. 4-50

Select [Next] to:



- d Change exposure parameter, collimator settings, etc. Settings can be defined for four different patient sizes; Very small, small, Medium, and Large for quick changes of exposure parameters.

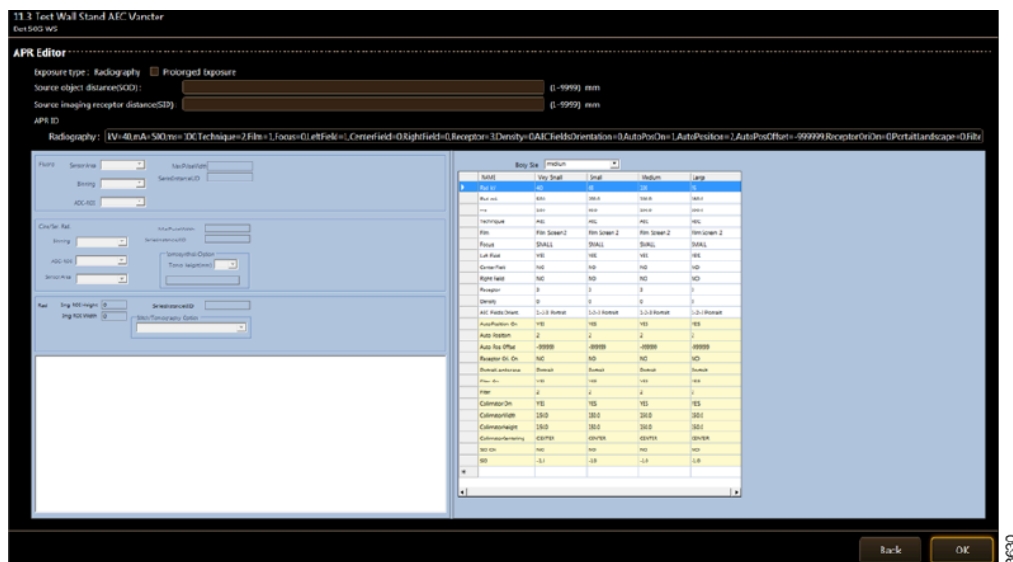

Fig. 4-51

Table 4-4

	Body Size <span style="float: right;">medium ▼</span>			
	Very Small	Small	Medium	Large
Rad kV	40	68	76	84
Rad mA	50.0	200.0	200.0	200.0
ms	10.0	80.0	80.0	80.0
Technique	MAS	MAS	MAS	MAS
Film	Film Screen 1	Film Screen 1	Film Screen 1	Film Screen 1
Focus	SMALL	SMALL	SMALL	SMALL
Left Field	NO	NO	NO	NO
Center Field	YES	YES	YES	YES
Right Field	NO	NO	NO	NO
Receptor	1	1	1	1
Density	0	0	0	0
AEC Fields Orient.	1-2-3	1-2-3	1-2-3	1-2-3
AutoPosition On	NO	NO	NO	NO
Auto Position	0	0	0	0
Auto Pos Offset	-999999	-999999	-999999	-999999
Receptor Ori. On	NO	NO	NO	NO
PortraitLandscape	Portrait	Portrait	Portrait	Portrait
Filter On	NO	NO	NO	NO
Filter	0	0	0	0
Collimator On	NO	NO	YES	NO
CollimatorWidth	-1.0	-1.0	300.0	-1
CollimatorHeight	-1.0	-1.0	600.0	-1
CollimatorCentering	N/A	N/A	N/A	N/A
SID On	NO	NO	NO	NO
SID	-1.0	-1.0	150.0	-1.0

# Operating the System

## Super User

The protocol parameters are specified below.

Table 4-5

Protocol parameter	Description
Rad kV	Define kV.
Rad mA	Define mA. Depending on selected Technique the value will be used either as the actual value or, in AEC mode, as backup value. This is indicated when the protocol is selected.
ms	Define ms for protocol. Depending on selected Technique the value will be used either as the selected value or, in AEC mode, as backup value. This is indicated when the protocol is selected.
mAs	Shows the mAs value (based on mA and ms values defined).
Technique	Select Technique: AEC or manual: MA/MS or MAS
Film	<i>Not used</i>
Focus	Small or Large Note. The system will override selection if selected exposure parameters requires a Large focus.
Left Field Center Field Right Field	Define active AEC chambers when AEC is selected as Technique YES = Active chamber, NO = Not active
Receptor	1 – Table 2 – Free detector at Table top 3 – Wallstand 4 – Free detector
Density	-8 > 0 > +8
AEC Field Orient.	<i>Not used</i>
Auto Position On	<i>NO – Not used</i>
Auto Position	<i>Not used</i>
Auto Pos Offset	<i>Not used</i>
Receptor Ori On	<i>NO – Not used</i>
PortraitLandscape	<i>Not used</i>
Filter On	YES: Automatic collimator NO: Manual collimator

Protocol parameter	Description
Filter	0, 1, 2, 3 Defines collimator filter (applicable for automatic collimator). Note, different filter applies depending on which automatic collimator that is included in the system.
Collimator On	YES: Automatic collimator NO: Manual collimator
Collimator Width	Unit mm or inch. Note! Width only needs to be defined for inch or mm (the other will be calculated).
Collimator Height	Unit mm or inch. Note! Height only needs to be defined for inch or mm (the other will be calculated).
Collimator Centering	For Wallstand, Collimator light filed alignment: Top, Center or Bottom.
SID On	YES: Automatic collimator NO: Manual collimator
SID	Define the SID for the specific protocol (when Automatic collimator is included).
GridInfo	DISABLED – <i>Not used</i>
Detector Stand Angle On	<i>NO – Not used</i>
Detector Stand Angle	<i>Not used</i>

# Operating the System

## Super User

### 4.10.2 Service Program, Log in

1. When Canon NE-application is running, the menu for restart is reached via (a) and (b).

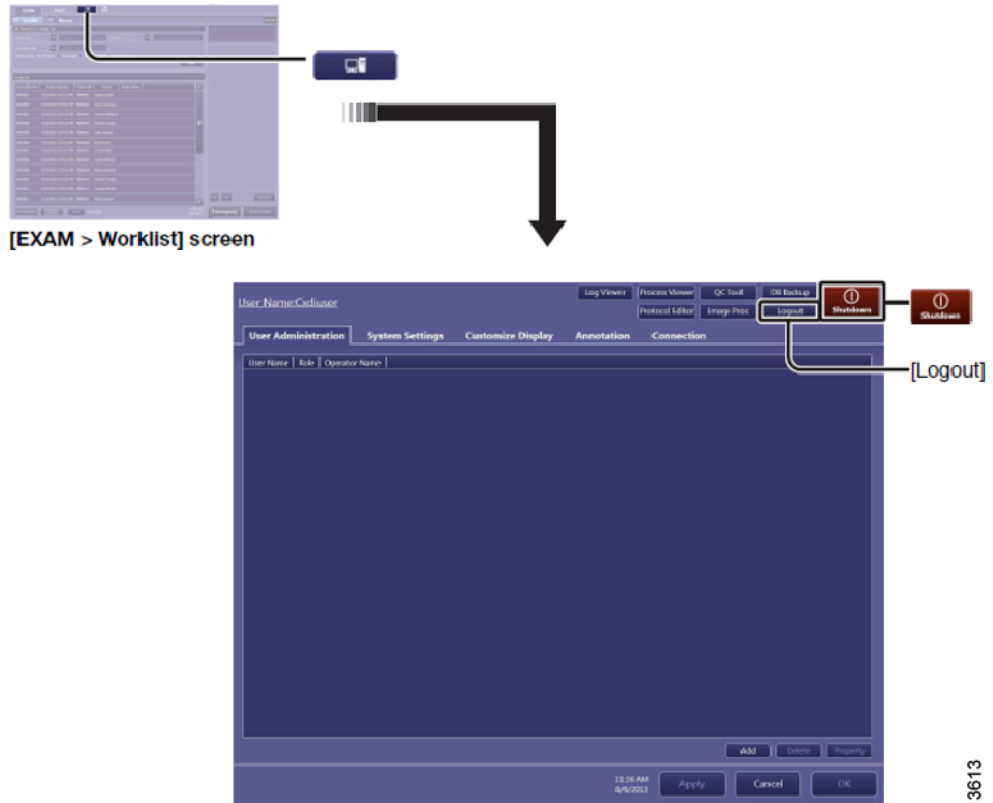

Fig. 4-52

In Canon NE-application:

- a Select  3611.
- b Select  3612.

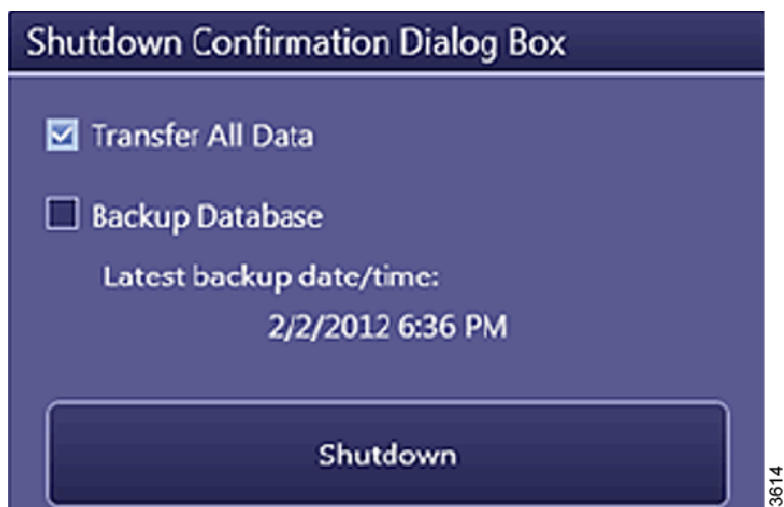

Fig. 4-53

2. Select Restart and Other Options.



Fig. 4-54

3. Select ServiceTool Start, log in the Service menu.

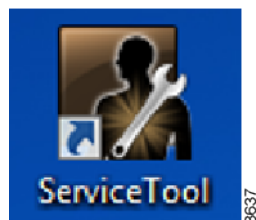

Fig. 4-55

The Service program can also be opened via the ServiceTool shortcut on the desktop.

### 4.10.3 Collect Log Files



Fig. 4-56 Menu Selection - Data Collection

1. In ServiceTool, select Data Collection.

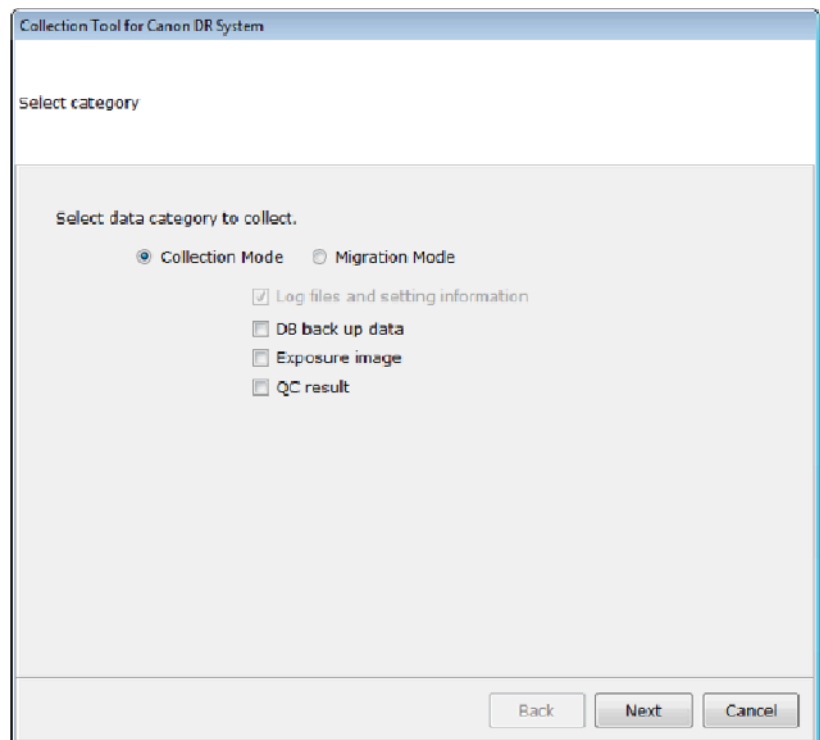

Fig. 4-57

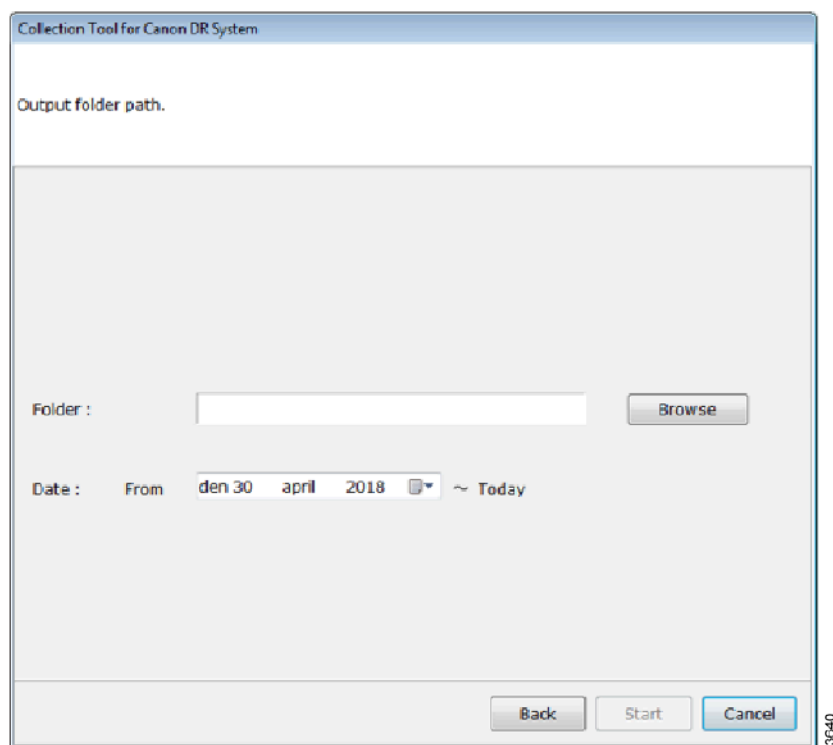

Fig. 4-58

2. Select location for the log file `Browse`.  
Date: Enter start and end date for the data collection .

### 4.10.4 Export Images



Fig. 4-59 Menu Selection - Image Import and Export

1. Select Image Import and Export.

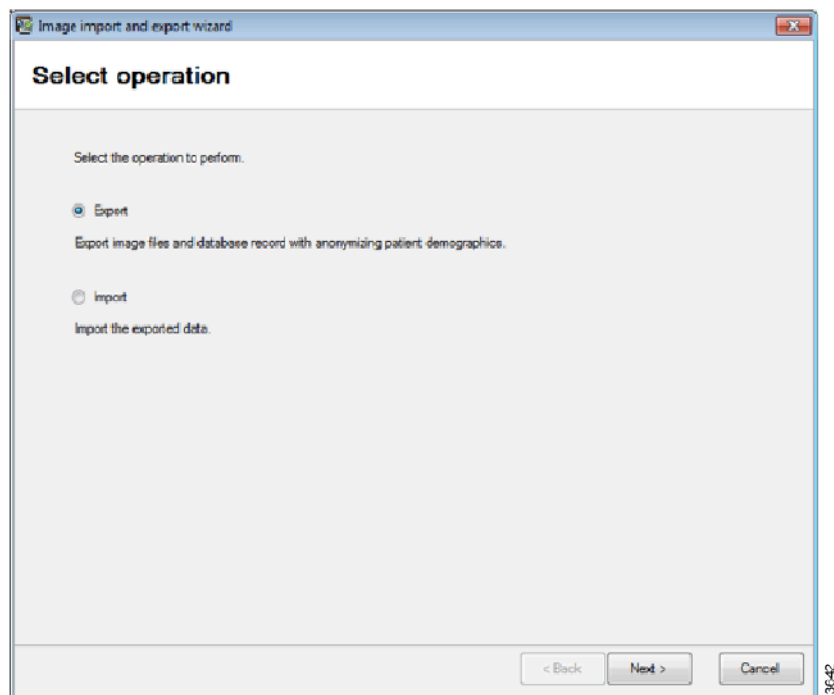

Fig. 4-60 Select operation menu

2. Select Export and press Next.



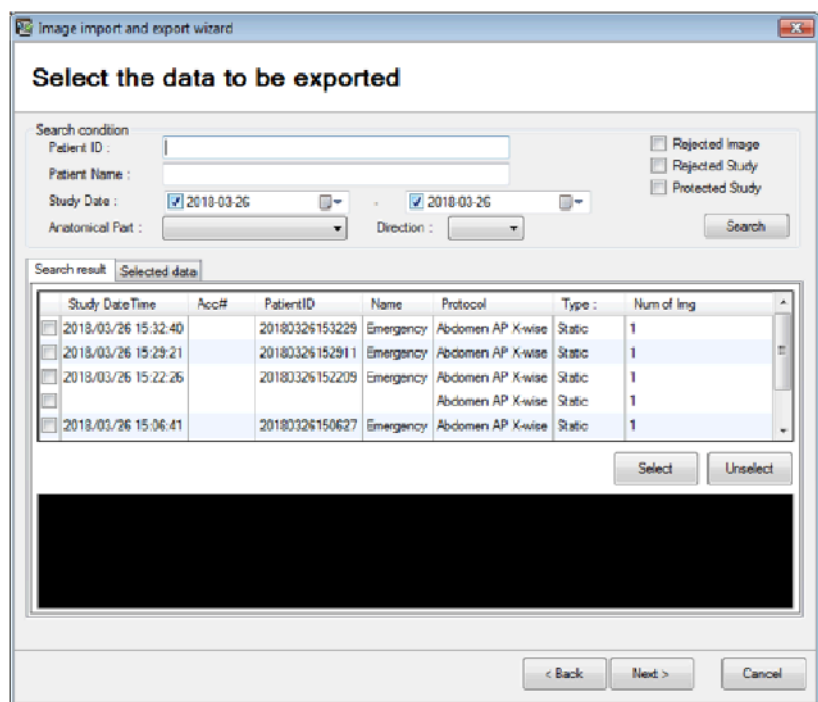

Fig. 4-61 Select data to be exported

3. Select images to export.

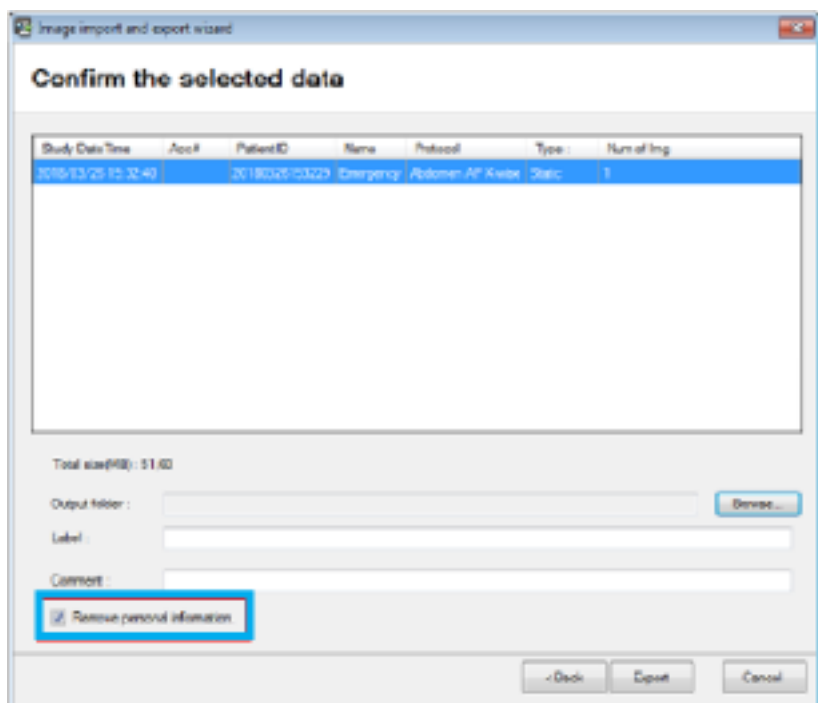

Fig. 4-62 Remove Personal information

4. Make sure that the box Remove Personal information is selected (default).

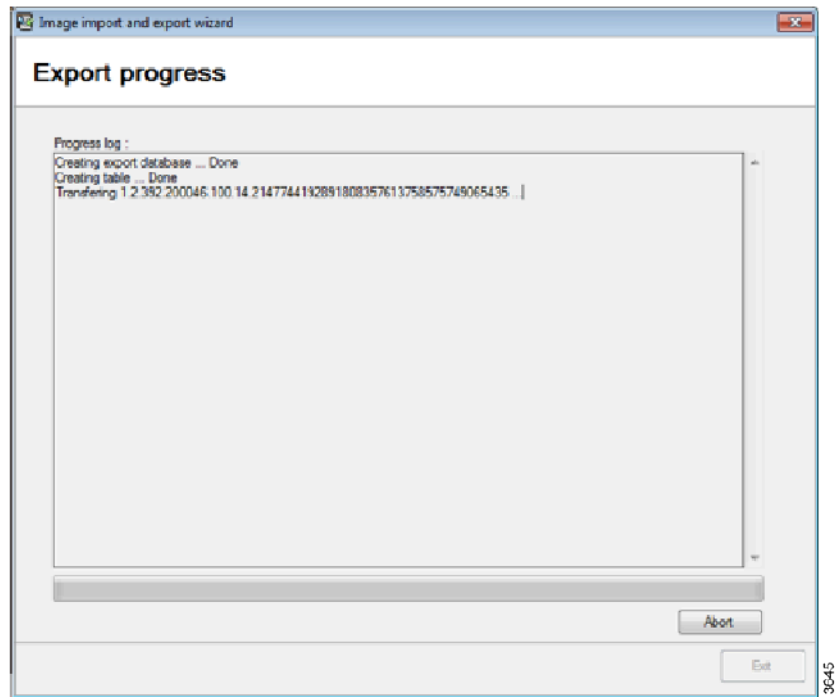

Fig. 4-63 Export progress menu

5. Export progress.

### 4.10.5 Adjustment of Protocol



Fig. 4-64 Menu selection - Protocol Editor

Adjustment of protocol can be performed in the NE-application and in the ServiceTool.

1. Select Protocol Editor.

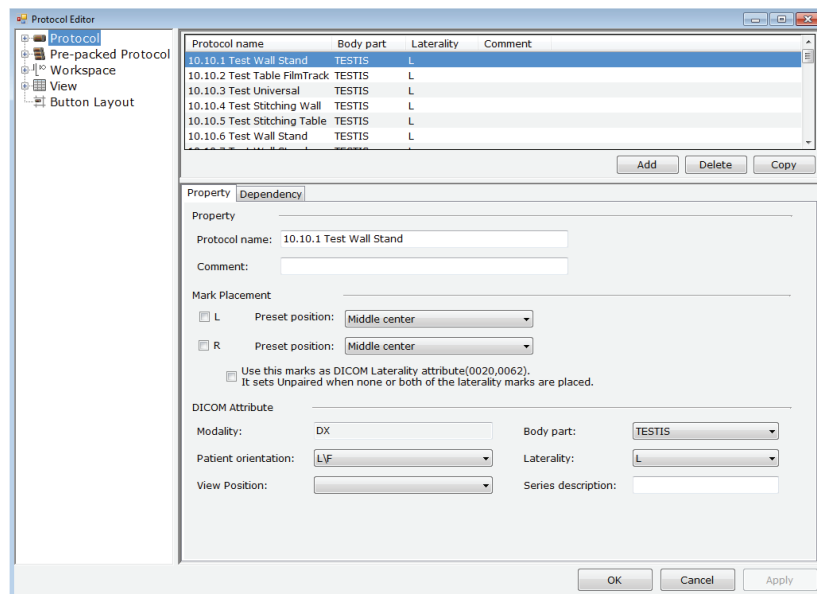

Fig. 4-65

2. Adjust protocol, pre-pack (connection to RIS), Workspace and View/Button Layout

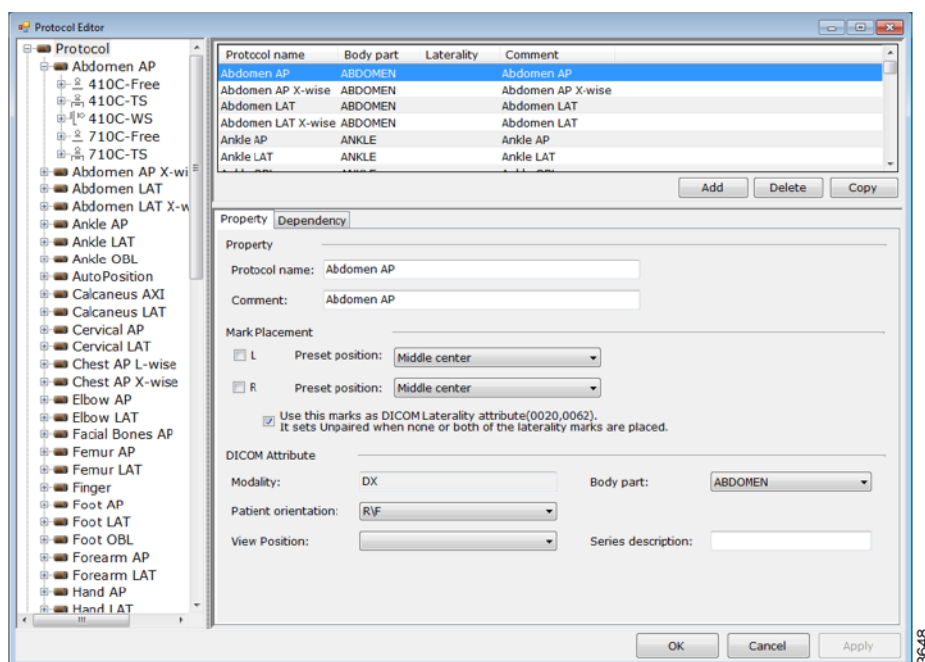

Fig. 4-66

3. In Protocol, possible workspaces for the actual examination are shown.

# Operating the System

## Super User

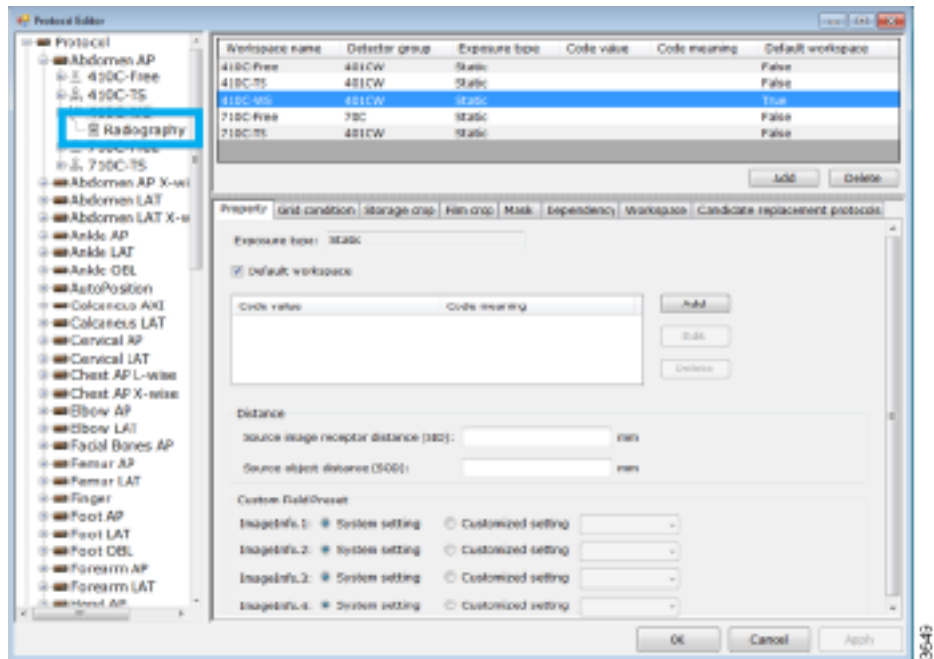

Fig. 4-67

4. Select Workspace and Radiography to show protocol settings.

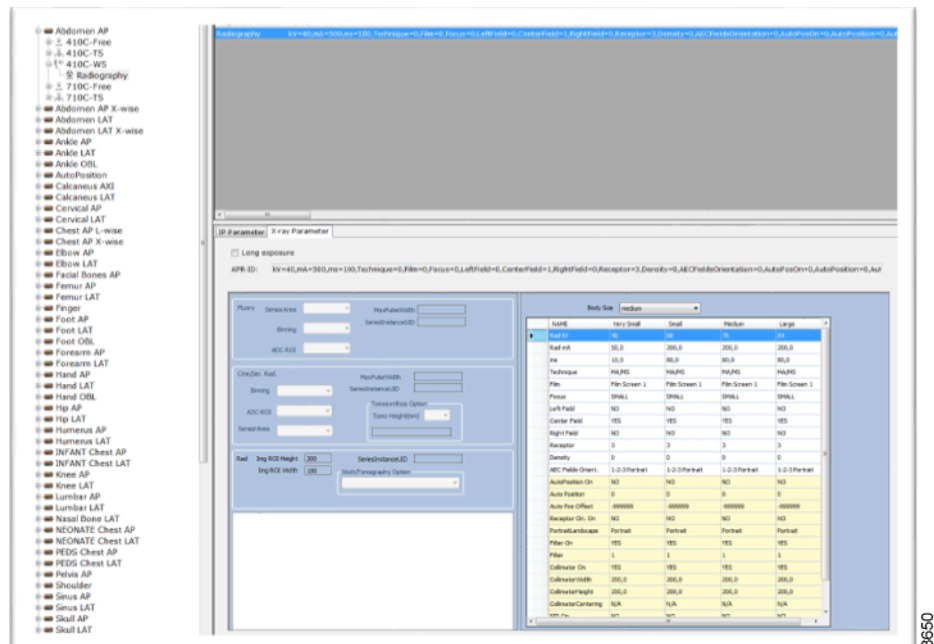

Fig. 4-68

### 4.10.6 Pre-pack – RIS-connection

In Pre-packed Protocol there is an overview of defined “pre-pack”.

1. Add and remove protocols.

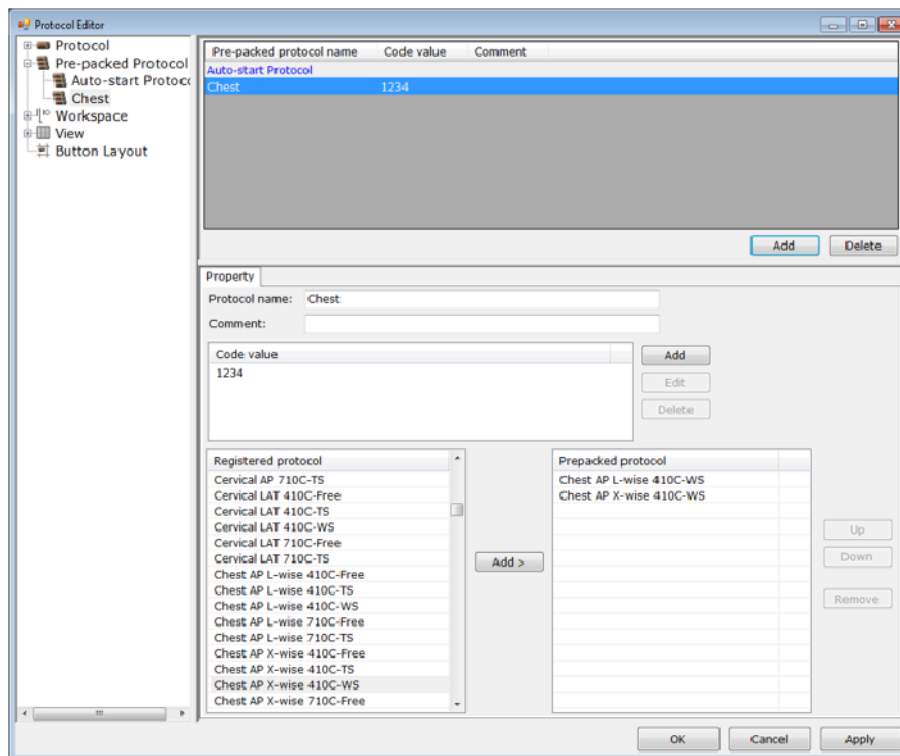
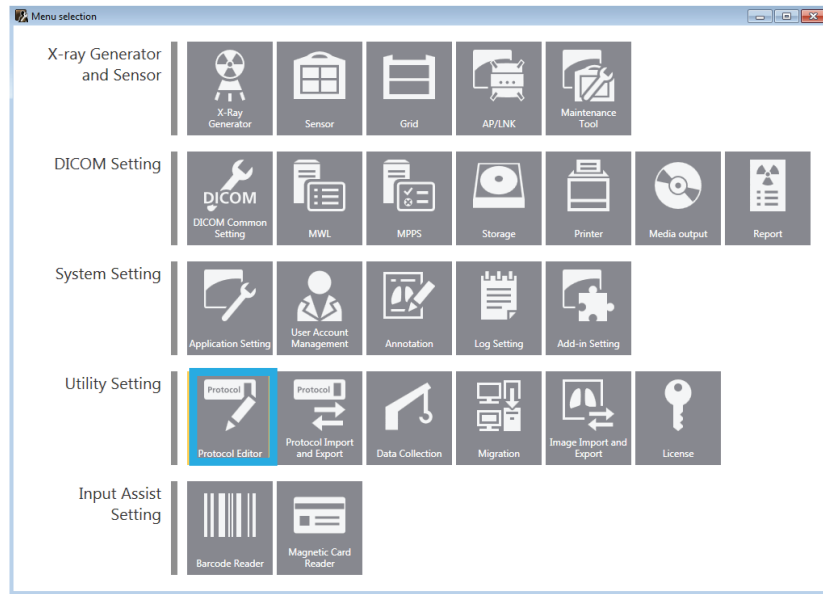

Fig. 4-69

### 4.10.7 Stitching Protocol Definition



3646

Fig. 4-70 Menu selection - Protocol Editor

1. Access Canon ServiceTool.
2. Select Protocol Editor.

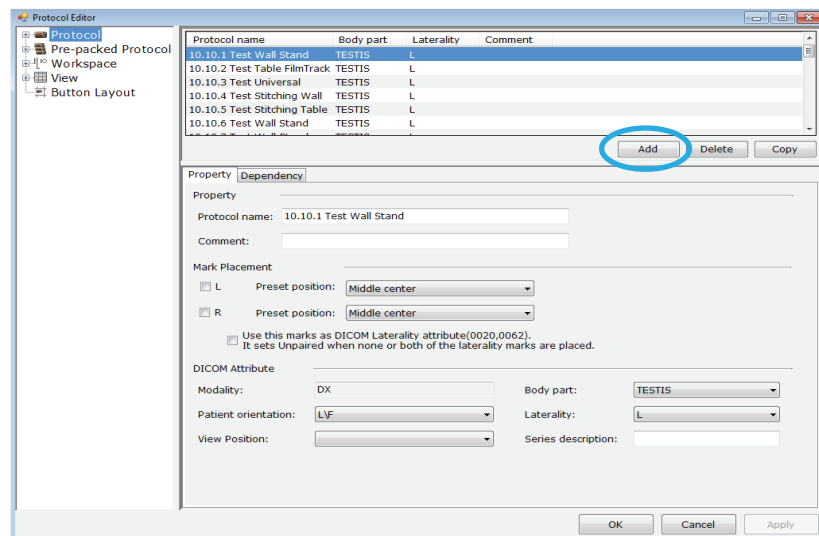

3516

Fig. 4-71 Protocol Editor menu

3. Select Add to define a stitching protocol.

New protocol - (1/4)

Property

Protocol name:

Comment:

Mark Placement

L Preset position:

R Preset position:

Use this marks as DICOM Laterality attribute(0020,0062).  
It sets Unpaired when none or both of the laterality marks are placed.

DICOM Attribute

Modality:

Body part:

Patient orientation:

Laterality:

View Position:

Series description:

Next >> Cancel

3654

Fig. 4-72 New Protocol page 1

# Operating the System

## Super User

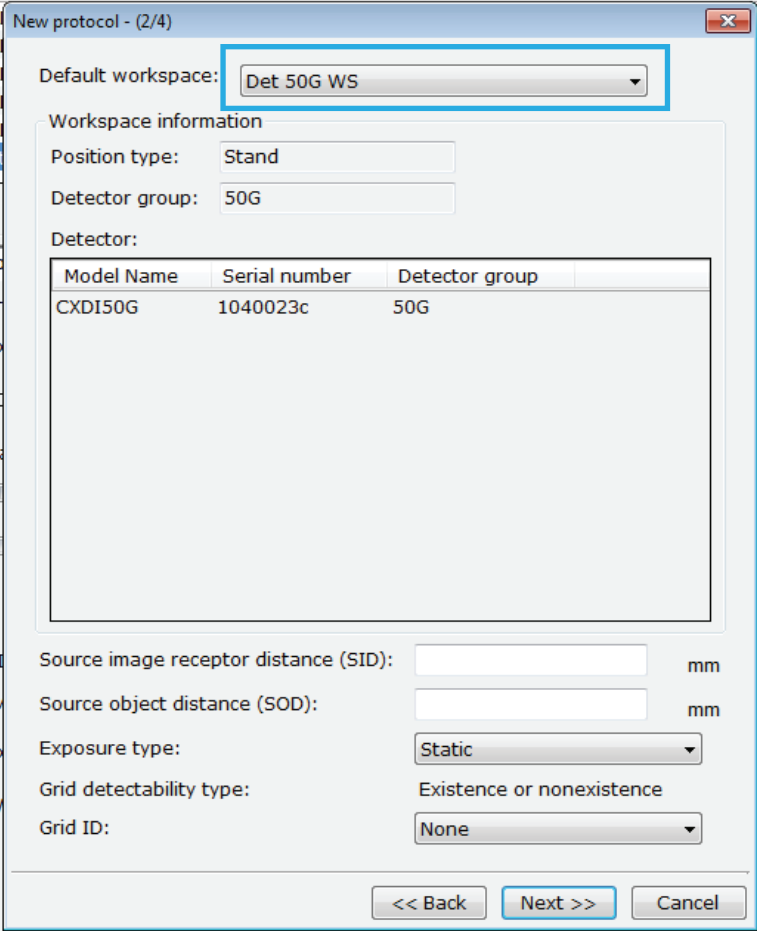

3654

Fig. 4-73 New Protocol page 2 - Default workspace

- 4. Select workspace wallstand.



Detector group:

Detector:

Model Name	Serial number	Detector group
CXDI50G	1040023c	50G

Source image receptor distance (SID):  mm

Source object distance (SOD):  mm

Exposure type:

Grid detectability type: Existence or nonexistence

Grid ID:

<< Back   Next >>   Cancel

3656

Fig. 4-74 New Protocol page 3 – Exposure type/Stitch

5. Select **Stitch** as Exposure type.

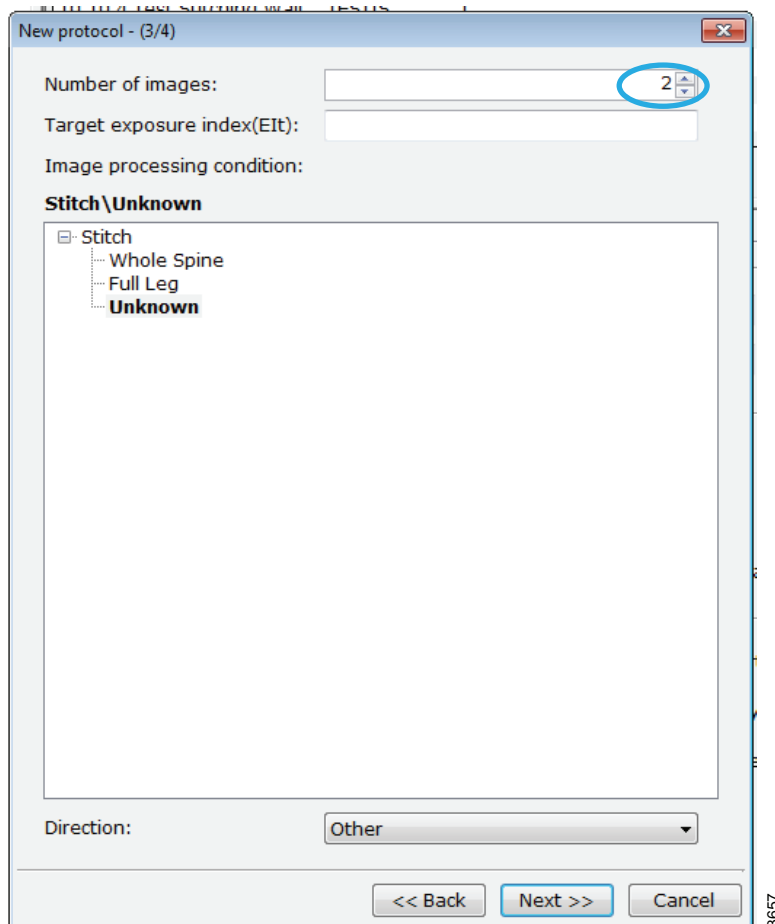

Fig. 4-75 New Protocol page 3 – Number of images

6. Define `Number of images` to be included in the stitching sequence.  
It is better to define one image more than expected than too few images. Based on the size of the region of interest, the system calculates the number of images needed and removes the protocols for images that are not exposed.  
A stitching protocol is now defined containing the number of protocols (Radiography) corresponding to the selected number of images.

The screenshot displays the 'JP Parameter' configuration window in the Intuition system. It includes a table of exposure parameters, a 'Long exposure' checkbox, and a detailed table of used parameters for different body sizes.

**Exposure Parameters Table:**

Exposure mode	APRID	APRName	Trigger
Stitch			1
Radiography (1)	kV=40,ms=100		1
Radiography (2)			1

**Long exposure parameters:**

APR-ID: kV=40, mA=500, ms=100, Technique=0, Film=0, Focus=0, LeftField=0, CenterField=1, RightField=0, Receptor=1, Density=0, AECFieldsOrientation=0, AutoPosOn=0, AutoPosition=0, AutoPosOffset=-9

**Used Parameters Table:**

NAME	Very Small	Small	Medium	Large
Rad KV	40	68	76	84
Rad mA	50.0	200.0	200.0	200.0
ms	10.0	80.0	80.0	80.0
Technique	MAS	MAS	MAS	MAS
Film	Film Screen 1	Film Screen 1	Film Screen 1	Film Screen 1
Focus	SMALL	SMALL	SMALL	SMALL
Left Field	NO	NO	NO	NO
Center Field	YES	YES	YES	YES
Right Field	NO	NO	NO	NO
Receptor	1	1	1	1
Density	0	0	0	0
AEC Fields Orient.	1-2-3	1-2-3	1-2-3	1-2-3
AutoPosition On	NO	NO	NO	NO
Auto Position	0	0	0	0
Auto Pos Offset	-999999	-999999	-999999	-999999
Receptor Ori. On	NO	NO	NO	NO
Portrait_landscape	Portrait	Portrait	Portrait	Portrait
Filter On	NO	NO	NO	NO
Filter	0	0	0	0
Collimator On	NO	NO	YES	NO
CollimatorWidth	-1.0	-1.0	300.0	-1
CollimatorHeight	-1.0	-1.0	500.0	-1
CollimatorCentering	N/A	N/A	N/A	N/A
SD On	NO	NO	NO	NO
SDn	-1.0	-1.0	150.0	-1.0

Fig. 4-76 Used parameters in Intuition system

- Define Exposure values, etcetera all included protocols/images.  
Define exposure parameters for the first protocol/image. Used parameters in Intuition system are framed.

# Operating the System

## Super User

NAME	Very Small	Small	Medium	Large
Rad mA	50.0	200.0	200.0	200.0
ms	10.0	80.0	80.0	80.0
Technique	MA/MS	MA/MS	MA/MS	MA/MS
Film	Film Screen 1	Film Screen 1	Film Screen 1	Film Screen 1
Focus	SMALL	SMALL	SMALL	SMALL
Left Field	NO	NO	NO	NO
Center Field	YES	YES	YES	YES
Right Field	NO	NO	NO	NO
Receptor	1	1	1	1
Density	0	0	0	0
AEC Fields Orient.	1-2-3 Portrait	1-2-3 Portrait	1-2-3 Portrait	1-2-3 Portrait
AutoPosition On	NO	NO	NO	NO
Auto Position	0	0	0	0
Auto Pos Offset	-999999	-999999	-999999	-999999
Receptor Ori. On	NO	NO	NO	NO
PortraitLandscape	Portrait	Portrait	Portrait	Portrait
Filter On	NO	NO	NO	NO
Filter	0	0	0	0
Collimator On	YES	YES	YES	YES
CollimatorWidth	-1.0	-1.0	300.0	-1.0
CollimatorHeight	-1.0	-1.0	600.0	-1.0
CollimatorCentering	N/A	N/A	N/A	N/A
SID On	YES	YES	YES	YES
SID	150.0	150.0	150.0	150.0

Fig. 4-77

8. First protocol:
  - a Define exposure parameters as for a regular protocol.
  - b Set Collimator On to YES.
  - c Define width and the expected total length of the stitched image.
  - d Set SID On to YES and define the SID value.

	NAME	Very Small	Small	Medium	Large
	Rad kV	40	68	76	84
	Rad mA	50.0	200.0	200.0	200.0
	ms	10.0	80.0	80.0	80.0
	Technique	MA/MS	MA/MS	MA/MS	MA/MS
	Film	Film Screen 1	Film Screen 1	Film Screen 1	Film Screen 1
	Focus	SMALL	SMALL	SMALL	SMALL
	Left Field	NO	NO	NO	NO
	Center Field	YES	YES	YES	YES
	Right Field	NO	NO	NO	NO
	Receptor	1	1	1	1
	Density	0	0	0	0
	AEC Fields Orient.	1-2-3 Portrait	1-2-3 Portrait	1-2-3 Portrait	1-2-3 Portrait
	AutoPosition On	NO	NO	NO	NO
	Auto Position	0	0	0	0
	Auto Pos Offset	-999999	-999999	-999999	-999999
	Receptor Ori. On	NO	NO	NO	NO
	PortraitLandscape	Portrait	Portrait	Portrait	Portrait
	Filter On	NO	NO	NO	NO
	Filter	0	0	0	0
	Collimator On	NO	NO	NO	NO
	CollimatorWidth	-1.0	-1.0	-1.0	-1.0
	CollimatorHeight	-1.0	-1.0	-1.0	-1.0
	CollimatorCentering	N/A	N/A	N/A	N/A
	SID On	NO	NO	NO	NO
	SID	-1.0	-1.0	-1.0	-1.0
*					

Fig. 4-78

9. Second and following protocols:
  - a Set Collimator On to YES for the second and third image.
  - b Set SID On to NO and no SID value shall be defined.

# Operating the System

Super User

---

## 5 Error Handling

For service issues or questions about the system maintenance, call your local service contractor.

### 5.1 Fault Handling

There are three types of NOTIFICATIONS - Shows the present occurrence. For example; collision. They are listed below in ranking order.

1. ERROR — The error information appears as a red bar in the lower part of the display. Sound; two beeps.
2. WARNING - Appears as a grey bar in the lower part of the display. Sound; one beep.
3. INFO - Not shown to the user. Only registered in the setting menu.

#### 5.1.1 Notifications

##### 5.1.1.1 Error

When an error occurs, an error pop-up window will appear in the display.

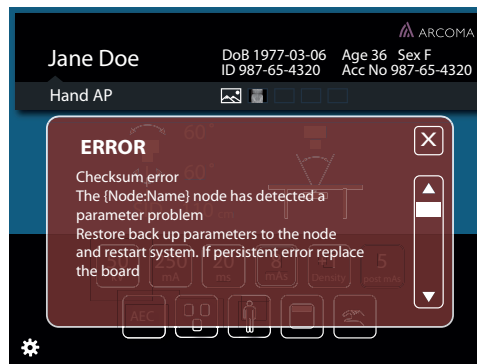

Fig. 5-1 Error pop-up window

The error pop-up window will disappear when the user pushes the close button.

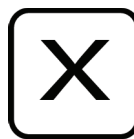

Fig. 5-2 Close button

# Error Handling

## Fault Handling

---

When closing the error pop-up window (**Fig. 5-1**), a red information bar will appear (see **Fig. 5-3** and **Fig. 5-4**).

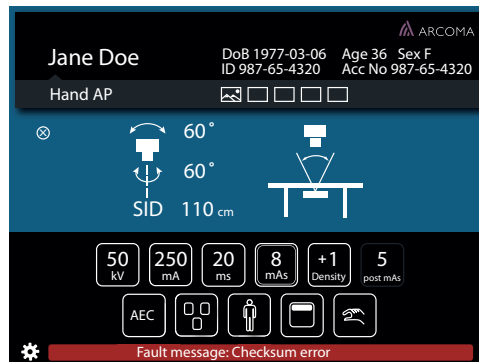

*Fig. 5-3 Error information bar, table*

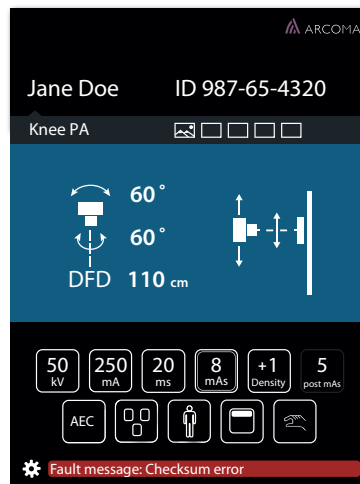

*Fig. 5-4 Error information bar, wallstand*

When the user pushes the red information bar, the error pop-up window will appear again. The error information bar (lower part of the window) is present until the error is fixed or the system is restarted.



### 5.1.1.2 Warning

A warning message will appear in a warning information bar (lower part of the display), when the handling of the system justifies that.

The warning information bar will be cleared if/when a new warning is displayed, or after time.

The latest sent warning is shown.

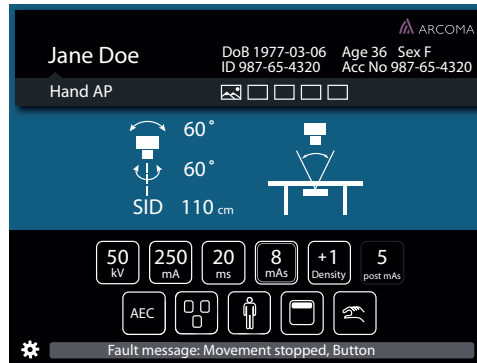

Fig. 5-5 Warning information bar, table

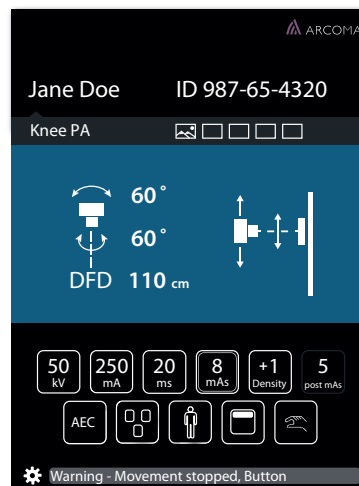

Fig. 5-6 Warning information bar, wallstand

# Error Handling

## Fault Handling

---

When pushing the warning information bar, (see **Fig. 5-5** and **Fig. 5-6**), a pop-up window will appear (see **Fig. 5-7** and **Fig. 5-8**).

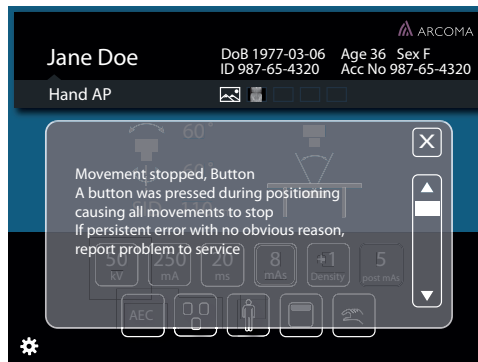

*Fig. 5-7 Pop-up window - warning information bar*

When the user closes the pop-up window, the warning information bar will appear again. The warning pop-up window will also appear again, when the user pushes the information bar.

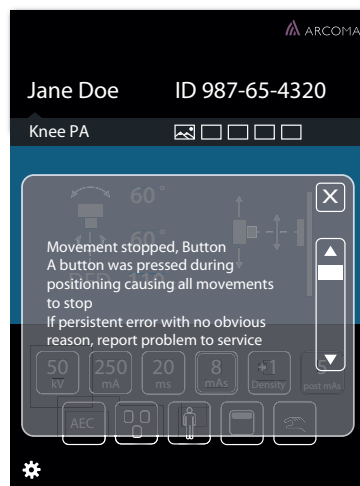

*Fig. 5-8 Pop-up window - information bar*

The warning pop-up window disappears when the user pushes the close button.



*Fig. 5-9 Close button*

### 5.1.1.3 Log

The *Log* file can be reopened via the *Service* menu or by pressing the gear or the Error/Warning messenger bars.

## 6 Cleaning and Disinfection

Cleaning is used for removal, usually with detergent and water or enzyme cleaner and water, of adherent visible soil, blood, protein substances, microorganisms and other debris from the surfaces, crevices, serrations, joints, devices, and equipment by a manual or mechanical process that prepares the items for safe handling and/or further decontamination.

Disinfection is used for chemical destruction of pathogenic and other types of microorganisms.

### 6.1 General

General guidelines for cleaning and disinfection of the system are given below.



---

#### **WARNING!**

##### ***Risk of electrical hazard or damage to the system***

- ***Before cleaning or disinfection, switch off the system to prevent electric shocks, for exceptions see 6.1.1 Cleaning and Disinfection Permitted with System Switched ON.***
  - ***Do not spray or pour cleaning liquid on any part of the system.***  
***Use a lint-free cloth moistened with a moderate amount of liquid to avoid that cleaning liquids seep into the openings of the system, e.g., air openings, gaps between covers.***
  - ***Do not restart the system if cleaning liquids have leaked in.***
- 

---

#### **CAUTION!**

##### ***Risk of damage***

***Use non-abrasive cleaning products to avoid scratches or damage to surfaces.***

---

### 6.1.1 Cleaning and Disinfection Permitted with System Switched ON

For cleaning and disinfection of the following parts, the system can stay switched on:

- Lateral armrest
- Patient grips
- Chin rest
- Front cover of Bucky unit
- Tabletop
- Maneuver Handle and Display

See also separate instruction for **6.4 Maneuver Handle and Display**.

# Cleaning and Disinfection

## Cleaning

---

### 6.2 Cleaning

- Wipe the system's parts with a lint-free cloth moistened with a moderate amount of mild soap or detergent solution until all visible signs of surface contaminants are removed.
- Remove all remaining cleaning residues and dry with a soft cloth.
- Keep the ventilation slots of all components unobstructed.
- Regularly clean the dust off all rails and joints etc.

See also separate instruction for **6.4 Maneuver Handle and Display**.

### 6.3 Disinfection

- Clean the surfaces/parts before disinfection according to **6.2 Cleaning**.
- Wipe the surface with a lint-free cloth moistened with a disinfectant.
- Do not spray any disinfectants directly on the surface.
- Obey the instructions of the manufacturer of the disinfectant.

See also separate instruction for **6.4 Maneuver Handle and Display**.

# Cleaning and Disinfection

## Maneuver Handle and Display

---

### 6.4 Maneuver Handle and Display

- Wipe the maneuver handle and display using a moderately moist cloth with water or alcohol-only cleaning agents only.
- Do not spray directly on the maneuver handle or the display.

## 7 Function and Safety Checks

### 7.1 AEC Functional Check

The following procedure may be used to verify that the AEC circuits are functioning on generators equipped with AEC (automatic exposure control).

1. Switch the generator ON, and select an appropriate radiographic image receptor.
2. Align the X-ray tube and the selected image receptor such that the central ray is directly over the center field of the AEC pickup device. Set the focal spot to film plane distance to 40 in. (1 m).
3. Select AEC mode of operation. Select center field, large focus.  
MINIMUM EXPOSURE TIME:
4. With no object in the radiation field, adjust the collimator or beam limiting device to project a 10 in. X 10 in. (24 cm X 24 cm) field at the image receptor.
5. Select 80 kVp, 100 mA, and a backup mAs of 50 if it is operator selectable. If this is not operator selectable, the default AEC backup settings must be used. Refer to the note at the end of this page to determine the AEC backup mode that has been programmed.
6. Make an exposure and verify that the POST mAs reading is 2 mAs.  
MAXIMUM EXPOSURE TIME:
7. Close the collimator or beam limiting device completely. Place a folded lead apron over the image receptor.
8. Select 60 kVp, 100 mA, and a backup mAs of 50 if it is operator selectable. If this is not operator selectable, the default backup settings must be used. Refer to the note at the end of this page to determine the AEC backup mode that has been programmed.
9. Make an exposure and verify that the AEC backup timer has terminated the exposure.

**Note!** \_\_\_\_\_

*The AEC backup mode is installer programmable. Three modes are available, **FIXED**, **MAS**, and **MS**. Only the **MAS** mode allows the operator to set the backup mAs for an AEC exposure.*

**FIXED:** The generator will determine the maximum AEC backup time, not to exceed pre-set AEC backup mAs/ms values or system limits. The characters **AEC** will be displayed in the time window of the LED display during AEC operation.

**MAS:** Allows the operator to adjust the AEC backup mAs, not to exceed preset AEC backup mAs/ms values or system limits. The mAs value will be displayed in the time window of the LED display during AEC operation.

**MS:** Allows the operator to adjust the AEC backup ms, not to exceed preset AEC backup mAs/ms values or system limits. The ms value will be displayed in the time window of the LED display during AEC operation.

# Function and Safety Checks

## Safety Checks

---

### 7.2 Safety Checks

#### 7.2.1 General

*Note!* \_\_\_\_\_

*Read the safety chapter before performing any maintenance.*

---

*Note!* \_\_\_\_\_

*For exchange of the collimator light field lamp, see the Collimator manual.*

---

If any malfunction is detected, the entire equipment must be taken out of use until the malfunction is eliminated by a service engineer from the supplier or by the local technical staff trained by the supplier.

Daily and monthly checks are normally performed by the user/operator.

Annual checks are performed by local technical staff trained by the supplied or authorized service representatives.

The Manufacturer recommends use of the checklist, see **13 Appendix B, Page 267**.

#### 7.2.2 Maintenance

To ensure the safety of the patients, the operators, and third parties, and to maintain reliability, the equipment must be checked according to Function and safety checks. If national rules or regulations specify more frequent checks and/or maintenance, such regulations must be observed.



### 7.3 Daily

Clean parts intended for patient touching.

See **6 Cleaning and Disinfection, Page 233**.

# Function and Safety Checks

## Monthly Checks

---

### 7.4 Monthly Checks

#### 7.4.1 Checklist

Use the checklist in **13 Appendix B, Page 267**.

##### 7.4.1.1 System

Actions for OTC, table and wallstand.

1. Check hoses for damage.
2. Check outer cabling for damage.
3. Clean outer surfaces, except for the lubricated column segments.
4. Check for proper installation, loose screws, foreign objects etc.  
If necessary, contact service representatives.
5. Check for oil leakage, etc.  
If necessary, contact service representatives.
6. Make sure the *Operation manual* is available and up to date.
7. Check emergency stops.  
See **2.11 Emergency Stop, Page 25**.

##### 7.4.1.2 OTC

1. Power up the OTC and check all functions.
2. Run Z up, listen for the ticking sound when movement starts and stops indicating proper function of contactor. Repeat procedure downwards.  
The OTC should run smoothly without noise.
3. Check SID.
  - a Choose table position and activate tracking.
  - b Measure between the X-ray tube focal spot and the active detector surface of the detector holder.  
The measured SID shall correspond with the displayed SID.
  - c Move the OTC in X or Y direction.
  - d Measure between the X-ray tube focal spot and the active detector surface of the detector holder.  
The SID is allowed to differ  $\pm 1\%$ .
4. Check that measured SID/FFD corresponds with SID displayed on the image system and the collimator.

##### 7.4.1.3 Closed Table

1. Check the movement of the table.  
The table should run smoothly without noise.
2. Move the table top and check that the mechanical end stops are properly installed.

##### 7.4.1.4 Two Column Table

1. Check the movement of the table.  
The table should run smoothly without noise.
2. Move the table top and check that the mechanical end stops are properly installed.

##### 7.4.1.5 Wallstand

1. Check the movement of the wallstand.  
The wallstand should run smoothly without noise.

### 7.5 Annual Checks

*See Installation and service manual.*

# Function and Safety Checks

## Annual Checks

---

## 8 Complying Standards

IEC 60601-1:2005+AMD1:2012+AMD2:2020 (edition 3.1)

- Medical electrical equipment: General requirements for basic safety and essential performance.

IEC 60601-1-2:2014 (4th edition)

- Medical electrical equipment : General requirements for basic safety and essential performance - Collateral Standard: Electromagnetic disturbances - Requirements and tests.

IEC 60601-1-3:2008+AMD1:2013

- Medical electrical equipment: General requirements for basic safety and essential performance - Collateral Standard: Radiation protection in diagnostic X-ray equipment.

IEC 60601-1-6:2010+AMD1:2013+AMD2:2020

- Medical electrical equipment: General requirements for basic safety and essential performance - Collateral standard: Usability.

IEC 62304:2006+AMD1:2015

- Medical device software - Software lifecycle processes.

IEC 62366-1:2015

- Medical devices - Part 1: Application of usability engineering to medical devices.

IEC 60601-2-28:2017

- Medical electrical equipment: Particular requirements for the basic safety and essential performance of X-ray tube assemblies for medical diagnosis.

IEC 60601-2-54:2009+AMD1:2015+AMD2:2018

- Particular requirements for the basic safety and essential performance of X-ray equipment for radiography and radioscopy.

EU Machinery Directive 2006/42/EC

# Complying Standards

---

## 9 Technical Specification

### 9.1 Classification

Classification according to IEC/EN 60601-1.

Class	Class I equipment. All dead metal parts of the equipment are electrical connected to protective earth.
Applied part	Type B
Protection against ingress of water	IPX0
Mode of operation	Intermittent operation: 20% 1 min ON / 4 min OFF
Use of anesthetic mixtures	The equipment is not suitable for use in the presence of flammable anesthetics mixtures with air, oxygen or nitrous oxide.

Classification according to IEC/EN 60601-1-2 Ed 3.0 2007 Class A.

Class	Class A
-------	---------

# Technical Specification

## Power Requirements

---

### 9.2 Power Requirements

Mains voltage for the System	400VAC 3Phase+N, +/-10%, 50/60Hz 400VAC 3Phase, +/-10%, 50/60Hz 480VAC 3Phase, +/-10%, 50/60Hz Long-time (positioning) 2 A 50/60 Hz. Momentary (exposure):150 A, 50/60 Hz (Short term peak value), (recommended fuse 63 A, thermal breaker, B curve.) Class 1
Heat dissipation	689 BTU/hr



# Technical Specification

## Power Line Requirements

---

### 9.3 Power Line Requirements

Generator Series and Mains Voltage	Generator Momentary Line Current	Apparent Mains Resistance	Recommended Minimum			
			Mains Disconnect to Generator (15 ft/5 m max)	Generator Service Rating	Distribution Transformer Rating	Ground Wire Size
50 kW 400 VAC, 3p	100 A	0.17 Ω	13.3 mm <sup>2</sup> (AWG 6)	100 A	65 kVa	13.3 mm <sup>2</sup> (AWG 6)
65 kW 400 VAC, 3p	125 A	0.13 Ω			85 kVa	
80 kW 400 VAC, 3p	155 A	0.10 Ω			105 kVa	
50 kW 480 VAC, 3p	80 A	0.24 Ω			65 kVa	
65 kW 480 VAC, 3p	105 A	0.19 Ω			85 kVa	
80 kW 480 VAC, 3p	130A	0.15 Ω			105 kVa	

# Technical Specification

## Radiographic Specification

### 9.4 Radiographic Specification

Radiographic performance	
kVp range:	40 to 150 kV
kVp steps:	variable in 1 kV steps
kVp accuracy:	$\pm (5 \% + 1 \text{ kV})$ measured 5 ms after the beginning of the exposure: $\pm 2\%$ between 70-80 kVp
Rise time (10-90%):	< 1.5 ms (typically < 1.0 ms) with 30 m (100 ft) Locaflex L3 or equivalent HV cables (4.4 $\mu\text{F}$ $\pm 10\%$ )
Time range:	1.0 to 6300 ms
Exposure time steps:	Variable in 1 ms steps via protocol: Variable according to ISO 497 Series R'20 via console
Exposure time accuracy:	$\pm (2\% + 0.5 \text{ ms})$ from 5 ms to 6300 ms and $> 0.5 \text{ mAs}$ $\pm (10\% + 1 \text{ ms})$ for $> 0.1 \text{ mAs}$ and for $< 5 \text{ ms}$ or $\leq 0.5 \text{ mAs}$ for 30 m (100 ft) HV cables
mAs range:	0.1 to 630 mAs (50 kW) 0.1 to 800 mAs (65 kW) 0.1 to 1000 mAs (80 kW) Note for Minimum mAs: mAs Mode: 0.3 mAs ( $> 60 \text{ kV}$ , 28 mA, 11 ms) mA, ms Mode: 0.3 mAs ( $> 60 \text{ kV}$ , 10 mA, 30 ms) mAs or mA, ms Mode: 0.1 m As (40 - 60 kV, 10 mA, 10 ms)
mAs accuracy:	$\pm (10 \% + 0.2 \text{ mAs})$ $\pm (10\% + 0.05) \text{ mAs}$ : 0.1 mAs - 0.5 mAs (preliminarily specified for the range beyond IEC standard)
mA range:	10 to 630 mA (50 kW) 10 to 800 mA (65 kW) 10 to 1000 mA (80 kW)
mA steps:	Variable in 0.1 mAs steps via protocol: Variable according to ISO 497 Series R'20 via console

# Technical Specification

## Radiographic Specification

<b>Radiographic performance</b>	
mA Accuracy (10 mA -1000 mA):	$\pm$ (5% +1 mA) for exposures $\geq$ 5 ms and $>$ 0.5 mAs: $\pm$ (20%) mA for exposures $>$ 0.1 mAs and for $<$ 5 ms or: $\leq$ 0.5 mAs: (0.1- 0.25 mAs, mA 50 mA)
Coefficient of linearity:	$\leq$ 0.1 for kV and mAs parameters
Coefficient of reproducibility:	$\leq$ 0.05 (Station to Station) for exposures $\geq$ 25 mA or 3.2 ms
Duty Cycle:	Not to exceed 5 consecutive boosts, followed by a minimum 10 second wait period

<b>Output Parameter and Loading Factor</b>		
<b>Output Parameter</b>	<b>Generator Series</b>	<b>Loading Factor</b>
Maximum X-ray tube voltage and highest X-ray tube current at that voltage	50 kW	150 kV, 320 mA
	65 kW	150 kV, 400 mA
	80 kW	150 kV, 500 mA
Maximum X-ray tube current and highest X-ray tube voltage at that current	50 kW	630 mA, 80 kV
	65 kW	800 mA, 81 kV
	80 kW	1000 mA, 80 kV
Combination of X-ray tube current and X-ray tube voltage resulting in highest output power	50 kW	500 mA, 100 kV, 0.1 s
	65 kW	630 mA, 100 kV, 0.1 s
	80 kW	800 mA, 100 kV, 0.1 s
Nominal shortest irradiation time (AEC exposures)	All models (AEC control is available over the full kV and mA range)	$<$ 2 ms with a dedicated or 3 of 5 field AEC board AEC control is achieved by varying the ms of the exposure. The AEC ms range is 15 ms to an installer-programmable maximum not to exceed 600 mAs.
AEC Accuracy	All models	Coefficient of variation of measured air kerma $\leq$ 0.05

# Technical Specification

## Environmental Requirements

---

### 9.5 Environmental Requirements

Ambient transport and storage temperature	-40 °C - +70 °C
Ambient operating temperature	+10 °C - +40 °C
Transport and storage humidity (relative)	10-90%, non-condensing
Operating humidity (relative)	30-75%, non-condensing
Atmospheric pressure range for transport, storage and operation	1060–700 hPa (-400 to +3000 meter, 795 to 525 mm Hg)

## 9.6 OTC

### 9.6.1 General

Rotation range ceiling (beta)	- 193°(±5°) ~ +155°(±10°)
Rotation range tube arm (alpha)	+193°(±5°) ~ -155°(±10°)
Column (Z stroke)	1700 mm, 1450 mm

### 9.6.2 Weight

OTC	127 kg
Tube and collimator	40 kg maximum allowed weight
Traverse rail X	60 kg
Ceiling rail Y (4 m standard)	16 kg

### 9.6.3 Speed

	Low speed	Maximum speed
Z movement	40 mm/s	150 mm/s

# Technical Specification

## Cabinet

---

### 9.7 Cabinet

#### 9.7.1 General

Dimensions (L x W x H) mm	750 x 610 x 1130
---------------------------	------------------

### 9.8 Closed Table

#### 9.8.1 Maximum Patient Load

Maximum patient load	295 kg
----------------------	--------

#### 9.8.2 Weight of Parts

Table (with table top and vertical lift)	241 kg
Table top	47 kg
Vertical lift	14 kg

#### 9.8.3 Vertical Lift

Lowest table top position (from the floor to the table top surface)	540 +20/-10 mm
Z stroke	310 +40/-20 mm
Maximum travel speed	25 mm/s (MRS ≥30 mm/s)

#### 9.8.4 Table Top

Dimensions	2400 mm X 800 mm
X-ray transparent area	2350 mm X 580 mm
Thickness	21 mm
Length of stroke X-direction from center position (Longitudinal)	±500 +20/-10 mm
Length of stroke Y-direction from center position (Lateral)	±150 +20/-10 mm
Aluminum equivalence	≤0.9 mm
Aluminum equivalence cover detector holder	< 0.6 mm

# Technical Specification

## Two Column Table (option)

---

### 9.9 Two Column Table (option)

#### 9.9.1 General

##### 9.9.1.1 Column

Two column table, with motorized vertical movement

Lowest table top position (from the floor to the table top surface)	550 mm
Column (Z stroke)	380 mm

##### 9.9.1.2 Table top

###### *Two Column Table with Manual or Motorized Detector Movement*

Dimensions	2400 mm X 853 mm
X-ray transparent area	2400 mm X 601 mm
Thickness	21.5 mm
Length of stroke, X-direction	+/- 600 mm
Length of stroke Y-direction	+/- 150 mm
Movement range of the detector	up to 850 mm
Aluminum equivalence	0.9 mm
Aluminum equivalence cover detector holder	< 0.6 mm

##### 9.9.1.3 Weight

Two column table, compl.	Maximum 147 kg
Table top	Maximum 47 kg
Maximum patient load	300 kg



### 9.10 Wallstand

Column, Z stroke	1470 +40/-10 mm (non-tilt) 1400 +40/-10 mm (tilt)
------------------	--

Rotation range detector holder wagon (Only the tiltable detector holder wagon).	-20° - 90°
---	------------

#### 9.10.1 Attenuation Equivalent

Detector holder	$\leq 0.6$ mm
-----------------	---------------

#### 9.10.2 Weight

Wallstand	Maximum 180 kg (160 +20/ -20 kg)
-----------	----------------------------------

# Technical Specification

## Wallstand

---

## 10 Waste Disposal

The manufacturing company is responsible for disposal of the product. To avoid environment pollution and human injury, we therefore request that you contact the manufacturer or your dealer if you wish to cease operation of your product with the intention of disposal.

For disposal of other components, refer to corresponding documentation.

Please follow the rules and regulations of your relevant authorities in the disposal of this product, accessories, options, consumables, media and their packing materials.



---

**WARNING!**

*Risk of electrical shock.*

*If covers are removed, live parts are exposed.*

---



---

**WARNING!**

*Be aware of possible squeezing hazards when the covers are removed.*

---



---

**WARNING!**

*Rotating parts can cause injury.*

*Do not get caught in a motor or other driving parts.*

---

---

**CAUTION!**

*Use gloves when in contact with grease.*

---

---

**CAUTION!**

*Be aware of sharp edges when the covers are removed.*

---

# Waste Disposal

---

## 11 Accessories and Options

### 11.1 General



**WARNING!**

---

*Risk of squeezing during motorized movements.*

*Only accessories approved by the manufacturer are allowed for the system.*

---

This chapter describes accessories that can be ordered for the system.

# Accessories and Options

## Options

---

### 11.2 Options

#### 11.2.1 General

Part no.	Description
	Unistruts for rails 4x4 m
	Unistruts for rails 4x5 m
	Mounting kit, unistruts for rails 4x4 m
	Mounting kit, unistruts for rails 4x5 m
	Traverse Y-kit
	Cable outlet for 0170-CS
0170-925-006	Extra mechanical index in ceiling rails for positioning (2 pieces)
0540-925-010	400 kHU X-ray tube, 40/100kW, 150 kV
0540-925-011	600 kHU X-ray tube, 40/100kW, 150 kV
0540-925-014	Automatic collimator and collimator handle for WS
0540-925-022	Automatic collimator with LED and collimator handle for WS

#### 11.2.2 Table

Part no.	Description
	Patient kit incl. ; - compression belt cost effective Patient handgrip (2 pieces) Mattress
0072-099-014	Patient handgrip
0072-099-028	Compression belt cost effective
0072-099-029	Compression belt high-end
0080-099-051	Form pad small- rectangle
0080-099-050	Form pad medium- wedge
0080-099-052	Form pad large- head
0072-099-011	Lateral cassette holder
0055-099-007	Table top mattress 2200 mm

### 11.2.2.1 Closed Table

Part no.	Description
	Maneuver handle, automatic collimator
0072-099-004	Foot control X/Y/Z

### 11.2.2.2 Two Column Table

Part no.	Description
	Maneuver handle, X/Y and Z
	Maneuver handle, automatic collimator
0072-099-004	Foot control X/Y/Z
	Foot control strip type X/Y

### 11.2.3 Wallstand

Part no.	Description
	Patient lateral armrest
	Grid 52lp/cm, R10:1, F140
	Grid 52lp/cm, R10:1 ratio F180
	Wall bracket
	Foot pedal Z movement release (maximum 2 pieces)
	Foot pedal Z movement release and motorized vertical movement (maximum 2 pieces)
	Cable outlet for WS

### 11.2.4 Detectors

The following detector options are available for the system:

CXDI-401C, wireless 43x43
CXDI-401C, 43x43 compact
CXDI-410C, wireless 43x43
CXDI-701C, wireless 35x43
CXDI-710C, wireless 35x43
CXDI-801C, wireless ~28x35
CXDI-810C, wireless ~28x35

# Accessories and Options

## Options

---

CXDI-402C, wireless 43x43
CXDI-702C, wireless 35x43

### 11.2.5 System Cabinet

Code	Description
0072-925-302	50 kW, 100 kHz — 200 kHz High frequency generator
0072-925-300	65 kW, 100 kHz — 200 kHz High frequency generator
0072-925-301	80 kW, 100 kHz — 200 kHz High frequency generator

### 11.2.6 Wallstand loading

Wallstand loading	
0180-925-203	Left-hand loading
0180-925-204	Right-hand loading



## 12 Appendix A

### 12.1 Glossary

#### A

Accessories	Extra facilities to the system which easily can be mounted by the user.
AEC	Automatic Exposure Control.
Alpha	A direction for a rotation movement.

#### B

Beta	A direction for a rotation movement. The tube turns around the Z-axis.
Btu/hr	British thermal unit/hour.
BU/Back-up	A precautionary measure that shuts off the exposure, if the AEC chamber does not.
Bucky	See Detector holder.

#### C

CE	A CE-marked product verifies that the Manufacturer guarantees that the product fulfils the EU fundamental health, environment and security requirements.
Centering	The field of image is centered over the detector.
Collision	Either a physical collision with an obstacle or the node cannot reach its end position.
CR	Image plates.

#### D

DAP meter	Dose Area Product meter. The DAP-meter is placed next to the collimator and measures the amount of X-ray radiation that leaves the collimator.
Diode	Electrical component that leads voltage and current in one direction.
Dealer	See "Supplier".
Detector	Image receptor for X-ray that does not require a cassette. The reception and transfer of an image is digital.

# Appendix A

## Glossary

---

### E

EMC	Electromagnetic Compatibility.
End stop	See mechanical end stop and software end stop.
Exposure	An image is taken against an image receptor.

### G

Guard function	Collision detection of the Z-movement (option).
Guard sensor	A sensor in the top of the Z-column that registers variations of force.

### I

IEC	International Electrotechnical Commission.
Image receptor	Receptor for images: Film, CR, DR, or Cassette.
Image receptor holder	Holder for the image receptor (Film, CR, DR or Cassette).
Index	Mechanical position markings, for instance alpha 0°, +90° and -90°.
Intermittence	The number of repetitions / unit of time. Recurrent cycles.
ISO	International Organization for Standardization.

### M

Mechanical end stop	A physical device that stops an automatic or manual movement if the software end stop is out of order.
Motorized movement	A motor assisted movement.

### N

Node	A control and supervision unit, consists of printed circuit board and node specific software.
------	---

### O

O.D.	Optic Density.
Options	Extra facilities that demand updating of the System software and hardware before use. Options demand installation of an authorized service technician.

### P

Position            A location in the room (X, Y and Z).

### S

SID                 Source to image distance. The distance between the focus spot in the X-ray tube and the active image receptor surface. FFD is also used.

Software end stop    A non-physical device that stops an automatic or manual movement. The software end stop is placed before the mechanical end stop.

SSW                Service software.

Supplier            The company that sells the System to the user (hospital).

### T

Table frame        The metallic frame that carries the Table top. The frame is attached to the bottom of the Table top.

### W

Working area        The size of the Table top including X- and Y-stroke.

### X

X-movement        The System moves in the X-direction.

### Y

Y-movement        The System moves in the Y-direction.

### Z

Z-node             The Z-node controls the Z-movement.

Z-movement        The System moves in the Z-direction.

# Appendix A

## Glossary

---

## **13 Appendix B**

### **13.1 Monthly Checklist**

Make a copy of this form before filling in.

If there is any discrepancy please use the table and make a note.

Hospital:.....

ID No:.....

Sign:.....

#### **13.1.1 System**

- 1. Check hoses for damage.
- 2. Check outer cabling for damage.
- 3. Clean outer surfaces, except for the lubricated column segments.
- 4. Make sure the Instruction for use is available and up to date.
- 5. Check emergency stops.

#### **13.1.2 OTC**

- 1. Check the movement of the OTC.
- 2. Check SID between X-ray tube focal spot and active detector surface.
- 3. Check that measured SID/FFD corresponds with SID displayed on the image system and the collimator.
- 4. Check all OTC functions.

#### **13.1.3 Closed Table**

- 1. Check the movement of the table.
- 2. Check the mechanical end stops.

# Appendix B

## Monthly Checklist

---

### 13.1.4 Two Column Table

- 1. Check the movement of the table.
- 2. Check the mechanical end stops.

### 13.1.5 Wallstand

- 1. Check the movement of the wallstand.

**13.1.6 Remark**

	Remark	Action	Internal note
1.	_____	_____	_____
2.	_____	_____	_____
3.	_____	_____	_____
4.	_____	_____	_____
5.	_____	_____	_____
6.	_____	_____	_____
7.	_____	_____	_____
8.	_____	_____	_____
9.	_____	_____	_____
10.	_____	_____	_____

# Appendix B

## Annual Checks

---

### 13.2 Annual Checks

Refer to Service and installation manual.



# Appendix B

## Annual Checks

---

